

## **SECTION 00 1113 - SUDAS NOTICE TO BIDDERS AND NOTICE OF PUBLIC HEARING**

### **JURISDICTION OF CITY OF RIVERSIDE PUBLIC IMPROVEMENT PROJECT**

Sealed bids for the work comprising each improvement as stated below must be filed before 2:00 P.M. according to the clock in the office of Riverside City Hall on January 25, 2024, in the office of the Riverside City Hall, 60 Greene Street in Riverside, Iowa. Bids received after the deadline for submission of bids as stated herein shall not be considered and shall be returned to the late bidder unopened.

Sealed proposals will be opened and bids tabulated at 2:00, P.M. on January 25, 2024, in Riverside City Hall for consideration by the City of Riverside at its meeting on February 05, 2024.

Work on the improvement shall be commenced immediately upon approval of the contract by the Council, and be completed as stated below.

Copies of the contract documents are available from Axiom Consultants, 300 S. Clinton St #200, Iowa City, Iowa 52240. Please contact Danielle Cavanary at [dcavanary@axiom-con.com](mailto:dcavanary@axiom-con.com) or (319) 519-6220 to request a copy of the bid documents. At the time of request, bidders will receive an electronic copy of the bidding plans and specifications. If a paper copy is requested, a full set of specifications and an 11"x17" size set of bidding plans will be mailed one time, free of charge to prospective bidder. Bidders are welcome to pick up paper copies from Axiom Consultants as long as they are requested prior to being picked up.

By virtue of statutory authority, preference will be given to products and provisions grown and coal produced within the State of Iowa, and to Iowa domestic labor, to the extent lawfully required under Iowa statutes.

In accordance with Iowa statutes, a resident bidder shall be allowed a preference as against a nonresident bidder from a state or foreign country if that state or foreign country gives or requires any preference to bidders from that state or foreign country, including but not limited to any preference to bidders, the imposition of any type of labor force preference, or any other form of preferential treatment to bidders or laborers from that state or foreign country. The preference allowed shall be equal to the preference given or required by the state or foreign country in which the nonresident bidder is a resident. In the instance of a resident labor force preference, a nonresident bidder shall apply the same resident labor force preference to a public improvement in this state as would be required in the construction of a public improvement by the state or foreign country in which the nonresident bidder is a resident.

### **GENERAL NATURE OF THE PUBLIC IMPROVEMENT**

#### **HALL PARK BOAT RAMP PHASE I PROJECT**

Summary Project Description: City of Riverside's Hall Park Boat Ramp Phase I project includes the clearing and grubbing (including removal of existing trees), installation of aggregate access drive and road, supply and replacement of rip rap, installation of new storm sewer, earthwork, traffic control, signage, erosion and sediment control, and restoration as noted on plans.

Each bidder shall accompany its bid with bid security as defined in Iowa Code Section 26.8, as security that the successful bidder will enter into a contract for the work bid upon and will furnish after the award of contract a corporate surety bond, in a form acceptable to the Jurisdiction, for the faithful performance of the contract, in an amount equal to 5% of the amount of the contract. The bidder's security shall be in the amount fixed in the Instruction to Bidders and shall be in the form of a cashier's check or a certified check drawn on an FDIC insured bank in Iowa or on an FDIC insured bank chartered under the laws of the United States; or a certified share draft drawn on a credit union in Iowa or chartered under the laws of the United States; or a bid bond on the form provided in the contract documents with corporate surety satisfactory to the Jurisdiction. The bid shall contain no condition except as provided in the specifications.

The City of Riverside reserves the right to defer acceptance of any bid for a period of sixty (60) calendar days after receipt of bids and no bid may be withdrawn during this period.

Each successful bidder will be required to furnish a corporate surety bond in an amount equal to 100% of its contract price. Said bond shall be issued by a responsible surety approved by City of Riverside and shall guarantee the faithful performance of the contract and the terms and conditions therein contained and shall guarantee the prompt payment of all material and labor, and protect and save harmless City of Riverside from claims and damages of any kind caused by the operations of the contract and shall also guarantee the maintenance of the improvement caused by failures in materials and construction for a period of two years from and after acceptance of the contract. The guaranteed maintenance period for new paving shall be four years.

The City of Riverside, in accordance with Title VI of the Civil Rights Act of 1964, 78 Stat. 252, 42U.S.C. 2000d to 2000d-4 and Title 49, Code of Federal Regulations, Department of Transportation, Subtitle A, Office of the Secretary, Part 21, Nondiscrimination in Federally-assisted programs of the Department of Transportation issued pursuant to such Act, hereby notifies all bidders that it will affirmatively insure that in any contract entered into pursuant to this advertisement, minority business enterprises will be afforded full opportunity to submit bids in response to this invitation and will not be discriminated against on the grounds of race, color, or national origin in consideration for an award.

Contractor shall fully complete the Base Bid project by (no later than) May 31, 2024.

The City of Riverside does hereby reserve the right to reject any or all bids, to waive informalities, and to enter into such contract, or contracts, as it shall deem to be in the best interest of the jurisdiction.

**THIS NOTICE IS GIVEN BY AUTHORITY OF THE CITY OF RIVERSIDE  
/S/ ALLEN SCHNEIDER, MAYOR  
CITY OF RIVERSIDE**

**END OF SECTION**



PROJECT MANUAL FOR:

**CITY OF RIVERSIDE**  
**HALL PARK BOAT RAMP PHASE 1**

Riverside, IA

December 22, 2023

INFORMATION:

**Bids Due:** January 25, 2024, at 2:00 p.m.  
**Bid Location:** Riverside City Hall – City Council Chambers  
60 Greene Street  
Riverside, Iowa 52327



60 E. COURT ST, IOWA CITY, IOWA 52240 | 319.519.6220

AXIOM PROJECT #: 21-0145

**SECTION 00 0101  
PROJECT TITLE PAGE**

**PROJECT MANUAL**

**FOR**

**23-0149 CITY OF RIVERSIDE HALL PARK BOAT RAMP PHASE I**

**ENGINEER'S PROJECT NUMBER: 23-0149**

**60 GREENE ST, RIVERSIDE, IA**

**DATE: 12/22/2023**

**PREPARED BY:**

**AXIOM CONSULTANTS, LLC**

**END OF SECTION**

## **SECTION 00 0102 PROJECT INFORMATION**

### **PART 1 - GENERAL**

#### **1.1 PROJECT IDENTIFICATION**

- A. Project Name: Hall Park Boat Ramp Phase I
- B. Engineer's Project Number: 23-0149  
Location: FCGC+82, Riverside, Iowa 52327  
Riverside, Iowa.
- C. The Owner, hereinafter referred to as Owner: City of Riverside
- D. Owner's Project Manager: Axiom Consultants, LLC.
  - 1. Project Lead: Brian Boelk.
  - 2. Address: 300 S. Clinton St #200.
  - 3. City, State, Zip: Iowa City, IA 52240.
  - 4. Phone/Fax: (319) 519-6220.
  - 5. E-mail: bboelk@axiom-con.com.

#### **1.2 NOTICE TO PROSPECTIVE BIDDERS**

- A. These documents constitute an Invitation to Bid to General Contractors for the construction of the project described below.

#### **1.3 PROJECT DESCRIPTION**

- A. Summary Project Description: City of Riverside's Hall Park Boat Ramp project includes the clearing and grubbing (including removal of existing trees), installation of aggregate access drive and road, supply and replacement of rip rap, installation of new storm sewer, earthwork, traffic control, signage, erosion and sediment control, and restoration as noted on plans.
- B. Contract Scope: Construction.
- C. Contract Terms: Unit Price.
  - 1. The base bid will include the full scope of work with the intent and purpose to award and construct the full project.
- D. The site is readily accessible and can be viewed at any time by interested contractors.

#### **1.4 PROCUREMENT TIMETABLE**

- A. Last Request for Substitution Due: 3 days prior to due date of bids.
- B. Last Pre-Bid Request for Clarification Due: 2 days prior to due date of bids.
- C. Bid Due Date: January 25, 2024, before 2 PM local time.
- D. Bid Opening: January 25, 2024 2 PM local time. Location: City Council Chambers, Riverside City Hall, 60 Greene Street, Riverside, Iowa.
- E. Notice to Proceed: Within 7 days after the City of Riverside Council Meeting, held: February 5, 2024.
- F. Overall Final Completion Date: Not later than May 31, 2024.
- G. The Owner reserves the right to change the schedule or terminate the entire procurement process at any time.

#### **1.5 PROCUREMENT DOCUMENTS**

- A. Availability of Documents: Complete sets of procurement documents may be obtained:
  - 1. From Engineer: Axiom Consultants, LLC.
  - 2. At the following address: 300 S. Clinton St #200, Iowa City, IA 52240.

3. Via email: [dcavanary@axiom-con.com](mailto:dcavanary@axiom-con.com); Phone: (319) 519-6220.

**END OF SECTION**

**SECTION 00 0107  
SEALS PAGE**

	I HEREBY CERTIFY THAT THIS ENGINEERING DOCUMENT WAS PREPARED BY ME OR UNDER MY DIRECT PERSONAL SUPERVISION AND THAT I AM A DULY LICENSED PROFESSIONAL ENGINEER UNDER THE LAWS OF THE STATE OF IOWA.	
	BRIAN A. BOELK, P.E. LICENSE NUMBER 16503.	DATE
	MY LICENSE RENEWAL DATE IS DECEMBER 31, 2024.	
	PAGES OR SHEETS COVERED BY THIS SEAL:	

**END OF SECTION**

**SECTION 00 0110  
TABLE OF CONTENTS**

**PROCUREMENT AND CONTRACTING REQUIREMENTS**

**DIVISION 00 -- PROCUREMENT AND CONTRACTING REQUIREMENTS**

- A. 00 0101 - Project Title Page
- 00 0102 - Project Information
- 00 0107 - Seals Page
- 00 0110 - Table of Contents
- 00 1113 - SUDAS Notice to Bidders
- 00 2113.01 - SUDAS Instruction to Bidders
- 00 4243 - SUDAS Proposal
- 00 4313 - SUDAS Bid Bond
- 00 5213 - SUDAS Contract
- 00 6113 - SUDAS Performance, Payment and Maintenance Bond
- 00 7200 - General Conditions

**SPECIFICATIONS**

**DIVISION 01 -- GENERAL REQUIREMENTS**

**THE IOWA STATEWIDE URBAN DESIGN AND SPECIFICATION (SUDAS), 2022 EDITION,  
SHALL APPLY AND BE USED AS SPECIFICATIONS FOR THIS PROJECT.**

**END OF SECTION**



## **SECTION 00 1113 - SUDAS NOTICE TO BIDDERS AND NOTICE OF PUBLIC HEARING**

### **JURISDICTION OF CITY OF RIVERSIDE PUBLIC IMPROVEMENT PROJECT**

Sealed bids for the work comprising each improvement as stated below must be filed before 2:00 P.M. according to the clock in the office of Riverside City Hall on January 25, 2024, in the office of the Riverside City Hall, 60 Greene Street in Riverside, Iowa. Bids received after the deadline for submission of bids as stated herein shall not be considered and shall be returned to the late bidder unopened.

Sealed proposals will be opened and bids tabulated at 2:00, P.M. on January 25, 2024, in Riverside City Hall for consideration by the City of Riverside at its meeting on February 05, 2024.

Work on the improvement shall be commenced immediately upon approval of the contract by the Council, and be completed as stated below.

Copies of the contract documents are available from Axiom Consultants, 300 S. Clinton St #200, Iowa City, Iowa 52240. Please contact Danielle Cavanary at [dcavanary@axiom-con.com](mailto:dcavanary@axiom-con.com) or (319) 519-6220 to request a copy of the bid documents. At the time of request, bidders will receive an electronic copy of the bidding plans and specifications. If a paper copy is requested, a full set of specifications and an 11"x17" size set of bidding plans will be mailed one time, free of charge to prospective bidder. Bidders are welcome to pick up paper copies from Axiom Consultants as long as they are requested prior to being picked up.

By virtue of statutory authority, preference will be given to products and provisions grown and coal produced within the State of Iowa, and to Iowa domestic labor, to the extent lawfully required under Iowa statutes.

In accordance with Iowa statutes, a resident bidder shall be allowed a preference as against a nonresident bidder from a state or foreign country if that state or foreign country gives or requires any preference to bidders from that state or foreign country, including but not limited to any preference to bidders, the imposition of any type of labor force preference, or any other form of preferential treatment to bidders or laborers from that state or foreign country. The preference allowed shall be equal to the preference given or required by the state or foreign country in which the nonresident bidder is a resident. In the instance of a resident labor force preference, a nonresident bidder shall apply the same resident labor force preference to a public improvement in this state as would be required in the construction of a public improvement by the state or foreign country in which the nonresident bidder is a resident.

### **GENERAL NATURE OF THE PUBLIC IMPROVEMENT**

#### **HALL PARK BOAT RAMP PHASE I PROJECT**

Summary Project Description: City of Riverside's Hall Park Boat Ramp Phase I project includes the clearing and grubbing (including removal of existing trees), installation of aggregate access drive and road, supply and replacement of rip rap, installation of new storm sewer, earthwork, traffic control, signage, erosion and sediment control, and restoration as noted on plans.

Each bidder shall accompany its bid with bid security as defined in Iowa Code Section 26.8, as security that the successful bidder will enter into a contract for the work bid upon and will furnish after the award of contract a corporate surety bond, in a form acceptable to the Jurisdiction, for the faithful performance of the contract, in an amount equal to 5% of the amount of the contract. The bidder's security shall be in the amount fixed in the Instruction to Bidders and shall be in the form of a cashier's check or a certified check drawn on an FDIC insured bank in Iowa or on an FDIC insured bank chartered under the laws of the United States; or a certified share draft drawn on a credit union in Iowa or chartered under the laws of the United States; or a bid bond on the form provided in the contract documents with corporate surety satisfactory to the Jurisdiction. The bid shall contain no condition except as provided in the specifications.

The City of Riverside reserves the right to defer acceptance of any bid for a period of sixty (60) calendar days after receipt of bids and no bid may be withdrawn during this period.

Each successful bidder will be required to furnish a corporate surety bond in an amount equal to 100% of its contract price. Said bond shall be issued by a responsible surety approved by City of Riverside and shall guarantee the faithful performance of the contract and the terms and conditions therein contained and shall guarantee the prompt payment of all material and labor, and protect and save harmless City of Riverside from claims and damages of any kind caused by the operations of the contract and shall also guarantee the maintenance of the improvement caused by failures in materials and construction for a period of two years from and after acceptance of the contract. The guaranteed maintenance period for new paving shall be four years.

The City of Riverside, in accordance with Title VI of the Civil Rights Act of 1964, 78 Stat. 252, 42U.S.C. 2000d to 2000d-4 and Title 49, Code of Federal Regulations, Department of Transportation, Subtitle A, Office of the Secretary, Part 21, Nondiscrimination in Federally-assisted programs of the Department of Transportation issued pursuant to such Act, hereby notifies all bidders that it will affirmatively insure that in any contract entered into pursuant to this advertisement, minority business enterprises will be afforded full opportunity to submit bids in response to this invitation and will not be discriminated against on the grounds of race, color, or national origin in consideration for an award.

Contractor shall fully complete the Base Bid project by (no later than) May 31, 2024.

The City of Riverside does hereby reserve the right to reject any or all bids, to waive informalities, and to enter into such contract, or contracts, as it shall deem to be in the best interest of the jurisdiction.

**THIS NOTICE IS GIVEN BY AUTHORITY OF THE CITY OF RIVERSIDE  
/S/ ALLEN SCHNEIDER, MAYOR  
CITY OF RIVERSIDE**

**END OF SECTION**

## **SECTION 00 2113.01 - SUDAS INSTRUCTIONS TO BIDDERS**

### **INSTRUCTIONS TO BIDDERS**

The work comprising the above referenced project shall be constructed in accordance with the 2022 edition of the SUDAS Standard Specifications and as further modified by supplemental specifications and special provisions included in the contract documents. The terms used in the contract revision of the documents are defined in said Standard Specifications. Before submitting your bid, review the requirements of Division 1, General Provisions and Covenants, in particular the sections regarding proposal requirements, bonding, contract execution and insurance requirements. Be certain that all documents have been completed properly, as failure to complete and sign all documents and to comply with the requirements listed below can cause your bid not to be read.

#### **I. BID SECURITY**

The bid security must be in the minimum amount of 5% of the total bid amount including all add alternates (do not deduct the amount of deduct alternates). Bid security shall be in the form of a cashier's check or a certified check, drawn on an FDIC insured bank in Iowa or drawn on an FDIC insured bank chartered under the laws of the United States; or a certified share draft drawn on a credit union in Iowa or chartered under the laws of the United States; or a bid bond executed by a corporation authorized to contract as a surety in Iowa or satisfactory to the Jurisdiction. The bid bond must be submitted on the enclosed Bid Bond form as no other bid bond forms are acceptable. All signatures on the bid bond must be original signatures in ink; facsimile (fax) of any signature or use of an electronic signature on the bid bond is not acceptable. Bid security other than said bid bond shall be made payable to City of Riverside. "Miscellaneous Bank Checks," and personal checks, as well as "Money Orders" and "Traveler's Checks" issued by persons, firms, or corporations licensed under Chapter 533C of the Iowa Code, are not acceptable bid security.

#### **II. SUBMISSION OF THE PROPOSAL AND IDENTITY OF BIDDER**

A. The proposal shall be sealed in an envelope, properly identified as the Proposal with the project title and the name and address of the bidder, and deposited with the Jurisdiction at or before the time and at the place provided in the Notice to Bidders. It is the sole responsibility of the bidder to see that its proposal is delivered to the Jurisdiction prior to the time for opening bids, along with the appropriate bid security sealed in a separate envelope identified as Bid Security and attached to the outside of the bid proposal envelope. Any proposal received after the scheduled time for the receiving of proposals will be returned to the bidder unopened and will not be considered. If the Jurisdiction provides envelopes for proposals and bid security, bidders shall be required to utilize such envelopes in the submission of their bids.

B. The following documents shall be completed, signed, and returned in the Proposal envelope. The bid cannot be read if any of these documents are omitted from the Proposal envelope.

##### **1. PROPOSAL – Complete each of the following parts:**

- Part B – Acknowledgment of Addenda, if any have been issued
- Part E – Bid Items, Quantities, and Prices
- Part I – Identity of Bidder (including the Bidder Status Form)

Sign the proposal. The signature on the proposal and all proposal attachments must be an original signature in ink signed by the same individual who is the Company Owner or an authorized Officer of the Company; copies or facsimile of any signature or electronic signatures will not be accepted. The Bidder Status Form is required by the Iowa Labor Commissioner, pursuant to the Iowa Administrative Code rule 875-156.2(1). The Bidder must complete and submit the Bidder Status Form, signed by an authorized representative of the Bidder, with their bid proposal. Under Iowa Administrative Code rule 875-156.2(1), failure to provide the Bidder Status Form with the bid may result in the bid being deemed non-responsive and may result in the bid being rejected. The Worksheet: Authorized to Transact Business from the Labor Commissioner is including on the following page and can be used to assist Bidders in completing the Bidder Status Form.

**END OF SECTION**

**SECTION 00 4243 - SUDAS PROPOSAL**

**PROPOSAL**

**PROPOSAL PART A – SCOPE**

The City of Riverside, hereinafter called the “Jurisdiction,” has need of a qualified contractor to complete the work comprising the below referenced improvement. The undersigned Bidder hereby proposes to complete the work comprising the below referenced improvement as specified in the contract documents, which are officially on file with the Jurisdiction, in the office of the City of Riverside, at the prices hereinafter provided in Part C of the Proposal, for the following described improvements:

**PROJECT DESCRIPTION: HALL PARK BOAT RAMP PHASE I**

Summary Project Description: City of Riverside's Hall Park Boat Ramp Phase I project includes the clearing and grubbing (including removal of existing trees), installation of aggregate access drive and road, supply and replacement of rip rap, installation of new storm sewer, earthwork, traffic control, signage, erosion and sediment control, and restoration as noted on plans.

**PROPOSAL PART B – ACKNOWLEDGMENT OF ADDENDA**

The Bidder hereby acknowledges that all addenda become a part of the contract documents when issued, and that each such addendum has been received and utilized in the preparation of this bid. The Bidder hereby acknowledges receipt of the following addenda by inserting the number of each addendum in the blanks below:

Addendum Number: \_\_\_\_\_ Addendum Number: \_\_\_\_\_  
Addendum Number: \_\_\_\_\_ Addendum Number: \_\_\_\_\_

and certifies that said addenda were utilized in the preparation of this bid.

**PROPOSAL PART C – SPECIFICATIONS**

The Bidder hereby acknowledges and certifies awareness that ALL applicable SUDAS specifications shall apply to this project. If there are questions, bidders shall clarify during the bidding process.

**PROPOSAL PART D – QUALITY ASSURANCE (TESTING)**

The Bidder hereby acknowledges the Contractor shall be responsible for contracting and scheduling all material testing as noted and required in SUDAS specifications. Engineer shall manage, review and provide oversight on such testing and results.

**PROPOSAL PART E – BID ITEMS, QUANTITIES, AND PRICES**

UNIT BID PRICE CONTRACTS: The Bidder must provide the Unit Bid Price, the Total Bid Price, any Alternate Prices, and the Total Construction Costs on the Proposal Attachment: Part C – Bid Items, Quantities, and Prices. In case of discrepancy, the Unit Bid Price governs. The quantities shown on the Proposal Attachment: Part C – Bid Items, Quantities, and Prices are approximate only, but are considered sufficiently adequate for the purpose of comparing bids. The Total Construction Cost plus any alternates selected by the Jurisdiction, shall be used only for comparison of bids. The Total

Construction Cost, including any Add-Alternates, shall be used for determining the sufficiency of the bid security.

#### **PROPOSAL PART F – GENERAL**

The Bidder hereby acknowledges that the Jurisdiction, in advertising for public bids for this project, reserves the right to:

1. Reject any or all bids. Award of the contract, if any, to be to the lowest responsible, responsive bidder; and
2. Reject any or all alternates in determining the items to be included in the contract. Designation of the lowest responsible, responsive bidder to be based on comparison of the total bid plus any selected alternates; and
3. Make such alterations in the contract documents or in the proposal quantities as it determines necessary in accordance with the contract documents after execution of the contract. Such alterations shall not be considered a waiver of any conditions of the contract documents, and shall not invalidate any of the provisions thereof; and

The Bidder hereby agrees to:

1. Enter into a contract, if this proposal is selected, in the form approved by the Jurisdiction, provide proof of registration with the Iowa Division of Labor in accordance with Chapter 91C of the Iowa Code, and furnish a performance, maintenance, and payment bond; and
2. Forfeit bid security, not as a penalty but as liquidated damages, upon failure to enter into such contract and/or to furnish said bond; and
3. Commence the work on the Base Bid project on or before a date to be specified in a written notice to proceed by the Jurisdiction, and to be Complete the project November 17, 2023.

#### **PROPOSAL PART G – NON-COLLUSION AFFIDAVIT**

The Bidder hereby certifies:

1. That this proposal is not affected by, contingent on, or dependent on any other proposal submitted for any improvement with the Jurisdiction; and
2. That no individual employed by the Bidder has employed any person to solicit or procure the work on this project, nor will any employee of the Bidder make any payment or agreement for payment of any compensation in connection with the procurement of this project; and
3. That no part of the bid price received by the Bidder was or will be paid to any person, corporation, firm, association, or other organization for soliciting the bid, other than the payment of their normal compensation to persons regularly employed by the Bidder whose services in connection with the construction of the project were in the regular course of their duties for the Bidder; and
4. That this proposal is genuine and not collusive or sham; that the Bidder has not colluded, conspired, connived, or agreed, directly or indirectly, with any bidder or person, to submit a sham bid or to refrain from bidding, and has not in any manner, directly or indirectly, sought, by agreement or collusion, or communication or conference, with any person, to fix the bid price of the Bidder or of any other bidder, and that all statements in this proposal are true; and
5. That the individual(s) executing this proposal have the authority to execute this proposal on behalf of the Bidder.

#### **PROPOSAL PART H – ADDITIONAL REQUIREMENTS**

Additional requirements are not applicable for this proposal.

**PROPOSAL ATTACHMENT: PART E**

**PART E – BID ITEMS, QUANTITIES, AND PRICES**

This is a Unit Bid Price Contract. The bidder must provide the Bid Price(s), any Alternate Price(s), and the Total of the Base Bid plus any Add-Alternates in this Proposal Attachment: Part E – Bid Items, Quantities, and Prices the total of the base bid plus any alternates selected by the Jurisdiction shall be used only for comparison of bids. The total of the Base Bid plus any Add-Alternates shall be used for determining the sufficiency of the bid security.

Anticipated Start Date: \_\_\_\_\_

Anticipated Completion Date: \_\_\_\_\_

ITEM	DESCRIPTION	UNIT	QTY	UNIT PRICE	EXTENDED PRICE
1.	<b>CLEARING AND GRUBBING</b>	LS	1.00	\$	\$
2.	<b>TOPSOIL - STRIP, STOCKPILE &amp; RE-SPREAD</b>	CY	400.00	\$	\$
3.	<b>EARTHWORK</b>	CY	1,050.00	\$	\$
4.	<b>STORM SEWER, 36" PVC</b>	LF	68.00	\$	\$
5.	<b>STORM MANHOLE, SW-401 - 7" DIA.</b>	EA	2.00	\$	\$
6.	<b>STORM STRUCTURES, 36" FES</b>	EA	1.00	\$	\$
7.	<b>RIP RAP, CLASS B</b>	TON	286.00	\$	\$
8.	<b>MODIFIED SUBBASE, 6"</b>	TON	245.00	\$	\$
9.	<b>MACADAM SUBBASE, 18"</b>	TON	683.00	\$	\$
10.	<b>SIGNAGE</b>	LS	1.00	\$	\$
11.	<b>TRAFFIC CONTROL</b>	LS	1.00	\$	\$
12.	<b>EROSION CONTROL MEASURES</b>	LS	1.00	\$	\$
13.	<b>SEEDING AND MULCH - PERMANENT - TYPE 1</b>	AC	0.50	\$	\$
<b>TOTAL BASE BID CONSTRUCTION COST</b>				<b>\$</b>	

NOTES:

1. The base bid will include the full scope of work with the intent and purpose to award and construct the full project.

**END OF SECTION**

**SECTION 00 4313 - SUDAS BID BOND**

**SAMPLE BID BOND FORM**

**KNOW ALL BY THESE PRESENTS:**

That we \_\_\_\_\_, as Principal, and \_\_\_\_\_, as Surety, are held and firmly bound unto \_\_\_\_\_, as Obligee, (hereinafter referred to as "the Jurisdiction"), in the penal sum of \_\_\_\_\_ dollars (\$ \_\_\_\_\_), or \_\_\_\_\_ percent of the amount bid in lawful money of the United States, for which payment said Principal and Surety bind themselves, their heirs, executors, administrators, successors, and assigns jointly and severally, firmly by these presents.

The condition of the above obligation is such that whereas the Principal has submitted to the Jurisdiction a certain proposal, in a separate envelope, and hereby made a part hereof, to enter into a contract in writing, for the following described improvements;

Summary Project Description: City of Riverside's Hall Park Boat Ramp Phase I project includes clearing and grubbing (including removal of existing trees), installation of aggregate access drive and road, supply and placement of rip rap, installation of new storm sewer, earthwork, traffic control, signage, erosion and sediment control, and restoration as noted on plans.

The Surety hereby stipulates and agrees that the obligations of said Surety and its bond shall be in no way impaired or affected by any extension of the time within which the Jurisdiction may accept such bid or execute such Contract; and said Surety does hereby waive notice of any such extension.

In the event that any actions or proceedings are initiated with respect to this Bond, the parties agree that the venue thereof shall be Washington County, State of Iowa. If legal action is required by the Jurisdiction against the Surety or Principal to enforce the provisions of the bond or to collect the monetary obligation incurring to the benefit of the Jurisdiction, the Surety or Principal agrees to pay the Jurisdiction all damages, costs, and attorney fees incurred by enforcing any of the provisions of this Bond. All rights, powers, and remedies of the Jurisdiction hereunder shall be cumulative and not alternative and shall be in addition to all rights, powers and remedies given to the Jurisdiction, by law. The Jurisdiction may proceed against Surety for any amount guaranteed hereunder whether action is brought against Principal or whether Principal is joined in any such action or actions or not.



**(CONT. BID BOND)**

NOW, THEREFORE, if said proposal by the Principal be accepted, and the Principal shall enter into a contract with Jurisdiction in accordance with the terms of such proposal, including the provision of insurance and of a bond as may be specified in the contract documents, with good and sufficient surety for the faithful performance of such contract, for the prompt payment of labor and material furnished in the prosecution thereof, and for the maintenance of said improvements as may be required therein, then this obligation shall become null and void; otherwise, the Principal shall pay to the Jurisdiction the full amount of the bid bond, together with court costs, attorney's fees, and any other expense of recovery.

Signed and sealed this \_\_\_\_\_ day of \_\_\_\_\_, 20\_\_\_\_\_.

**SURETY**

SURETY COMPANY: \_\_\_\_\_

SIGNATURE ATTORNEY-IN-FACT/OFFICER:

\_\_\_\_\_

PRINTED ATTORNEY-IN-FACT/OFFICER:

\_\_\_\_\_

SURETY ADDRESS: \_\_\_\_\_

SURETY TELEPHONE NUMBER: \_\_\_\_\_

**PRINCIPAL**

BIDDER COMPANY: \_\_\_\_\_

BIDDER SIGNATURE:

\_\_\_\_\_

PRINTED NAME: \_\_\_\_\_

TITLE: \_\_\_\_\_

BIDDER ADDRESS: \_\_\_\_\_

BIDDER TELEPHONE NUMBER: \_\_\_\_\_

NOTE: All signatures on this bid bond must be original signatures in ink; copies, facsimile, or electronic signatures will not be accepted. This bond must be sealed with the Surety's raised, embossing seal. The certificate or power of attorney accompanying this bond must be valid on its face and sealed with the Surety's raised, embossed seal.

**END OF SECTION**

**SECTION 00 5213 - SUDAS CONTRACT**

**SAMPLE CONTRACT FORM**

**CONTRACT NO.** \_\_\_\_\_

**DATE:** \_\_\_\_\_

THIS CONTRACT, made and entered into at CITY OF RIVERSIDE, IOWA this \_\_\_\_\_ day of \_\_\_\_\_, 20\_\_\_\_, by and between the CITY OF RIVERSIDE, IOWA by and upon order of its MAYOR hereinafter called the "Jurisdiction," and \_\_\_\_\_, hereinafter called the "Contractor."

**WITNESSETH:**

The Contractor hereby agrees to complete the work comprising the below referenced improvement as specified in the contract documents, which are officially on file with the Jurisdiction, in the office of the CITY OF RIVERSIDE, IOWA. This contract includes all contract documents. The work under this contract shall be constructed in accordance with the SUDAS Standard Specifications, 2022 Edition, and as further modified by the supplemental specifications and special provisions included in said contract documents, and the Contract Attachment - Item 1: General, which is attached hereto. The Contractor further agrees to complete the work in strict accordance with said contract documents, and to guarantee the work as required by law, for the time required in said contract documents, after its acceptance by the Jurisdiction.

This contract is awarded and executed for completion of the work specified in the contract documents for the bid prices shown on the Contract Attachment - Item 2: Bid Items, Quantities, and Prices, which were proposed by the Contractor in its proposal submitted in accordance with the Notice to Bidders and Notice of Public Hearing for the following described improvements:

Summary Project Description: City of Riverside's Hall Park Boat Ramp Phase I project includes clearing and grubbing (including removal of existing trees), installation of aggregate access drive and road, supply and placement of rip rap, installation of new storm sewer, earthwork, traffic control, signage, erosion and sediment control, and restoration as noted on plans.

The Contractor agrees to perform said work for and in consideration of the Jurisdiction's payment of the bid amount of \_\_\_\_\_ dollars (\$\_\_\_\_\_) which amount shall constitute the required amount of the performance, maintenance, and payment bond. The Contractor hereby agrees to commence work under this contract on or before a date to be specified in a written notice to proceed by the Jurisdiction and to fully complete the project \_\_\_\_\_.

The Contractor agrees to provide progress payments based on Applications for Payment submitted to the Engineer by the Contractor and approval for payment issued by the Engineer, the Jurisdiction shall make progress payments on account of City Council's approval of the Contract Sum to the Contractor as provided below. The period covered by each Application for Payment shall be on calendar month ending on the last day of the month and provided to the Engineer not later than the 3rd Wednesday of a month. For each progress payment made prior to Substantial Completion of the Work, the Jurisdiction may withhold retainage from the payment in the amount of 5%. Final payment, constituting the entire paid balance for the Contract Sum, shall be made by the Jurisdiction to the Contractor when

1. The Contractor has fully performed the Contract except for the Contractor's responsibility to correct Work to satisfy other requirements, if any, which extend beyond final payment;
2. A final Certificate for Payment has been issued by the Engineer.

The Jurisdiction's final payment to the Contractor shall be made no later than 30 days after the issuance of the Engineer's final Certificate of Payment.

IN WITNESS WHEREOF, the Parties hereto have executed this instrument, in triplicate on the date first shown written.

**JURISDICTION**

BY: \_\_\_\_\_

(SEAL)

ATTEST: \_\_\_\_\_

FORM APPROVED BY:

\_\_\_\_\_ (ATTORNEY FOR JURISDICTION)

**CONTRACTOR**

COMPANY NAME: \_\_\_\_\_

SIGNATURE: \_\_\_\_\_

TITLE: \_\_\_\_\_

ADDRESS: \_\_\_\_\_

TELEPHONE: \_\_\_\_\_

**CONTRACT ATTACHMENT**

**CONTRACT ATTACHMENT: ITEM 1 - GENERAL**

No additional contract requirements

**CONTRACT ATTACHMENT: ITEM 2 - BID ITEMS AND QUANTITIES (SAMPLE FORM)**

This contract is awarded and executed for completion of the work specified in the contract documents for the the bid prices tabulated as proposed by the Contractor in its proposal submitted in accordance with notice to bidders and notice of public hearing. All quantities are subject to revision by the Jurisdiction. Quantity changes that amount to 20% or less of the amount bid shall not affect the unit bid price.

**The awarded Contractor's Base Bid Form and the selected Alternate Bid Form will be included as an attachment to the Contract.**

**END OF SECTION**

**SECTION 00 6113 - SUDAS PERFORMANCE, PAYMENT AND MAINTENANCE BOND**

**SAMPLE PERFORMANCE, PAYMENT AND MAINTENANCE BOND FORM**

**SURETY BOND NO.** \_\_\_\_\_

**PERFORMANCE, PAYMENT, AND MAINTENANCE BOND**

**KNOW ALL BY THESE PRESENTS:**

That we, \_\_\_\_\_, as Principal (hereinafter the "Contractor" or "Principal" and \_\_\_\_\_, as Surety are held and firmly bound unto \_\_\_\_\_, as Obligee (hereinafter referred to as "the Jurisdiction"), and to all persons who may be injured by any breach of any of the conditions of this Bond in the penal sum of \_\_\_\_\_ dollars (\$ \_\_\_\_\_), lawful money of the United States, for the payment of which sum, well and truly to be made, we bind ourselves, our heirs, legal representatives and assigns, jointly or severally, firmly by these presents.

The conditions of the above obligations are such that whereas said Contractor entered into a contract with the Jurisdiction, bearing date the \_\_\_\_\_ day of \_\_\_\_\_, hereinafter the "Contract") wherein said Contractor undertakes and agrees to construct the following described improvements:

Summary Project Description: City of Riverside's Hall Park Boat Ramp Phase I project includes clearing and grubbing (including removal of existing trees), installation of aggregate access drive and road, supply and replacement of rip rap, installation of new storm sewer, earthwork, traffic control, signage, erosion and sediment control, and restoration as noted on plans.

and to faithfully perform all the terms and requirements of said Contract within the time therein specified, in a good and workmanlike manner, and in accordance with the Contract Documents. Provided, however, that one year after the date of acceptance as complete of the work under the above referenced Contract, the maintenance portion of this Bond shall continue in force but the penal sum for maintenance shall be reduced to the sum of \_\_\_\_\_ DOLLARS (\$ \_\_\_\_\_), which is the cost associated with those items shown on the proposal and in the Contract that require a maintenance bond period in excess of one year.

It is expressly understood and agreed by the Contractor and Surety in this bond that the following provisions are a part of this Bond and are binding upon said Contractor and Surety, to-wit:

- 1. **PERFORMANCE:** The Contractor shall well and faithfully observe, perform, fulfill, and abide by each and every covenant, condition, and part of said Contract and Contract Documents, by reference made a part hereof, for the above referenced improvements, and shall indemnify and save harmless the Jurisdiction from all outlay and expense incurred by the Jurisdiction by reason of the Contractor's default of failure to perform as required. The Contractor shall also be responsible for the default or failure to perform as required under the Contract and Contract Documents by all its subcontractors, suppliers, agents, or employees furnishing materials or providing labor in the performance of the Contract.

2. PAYMENT: The Contractor and the Surety on this Bond hereby agreed to pay all just claims submitted by persons, firms, subcontractors, and corporations furnishing materials for or performing labor in the performance of the Contract on account of which this Bond is given, including but not limited to claims for all amounts due for labor, materials, lubricants, oil, gasoline, repairs on machinery, equipment, and tools, consumed or used by the Contractor or any subcontractor, wherein the same are not satisfied out of the portion of the contract price the Jurisdiction is required to retain until completion of the improvement, but the Contractor and Surety shall not be liable to said persons, firms, or corporations unless the claims of said claimants against said portion of the contract price shall have been established as provided by law. The Contractor and Surety hereby bind themselves to the obligations and conditions set forth in Chapter 573 of the Iowa Code, which by this reference is made a part hereof as though fully set out herein.

3. MAINTENANCE: The Contractor and the Surety on this Bond hereby agree, at their own expense:

A. To remedy any and all defects that may develop in or result from all work except new paving to be performed under the Contract within the period of (2) years from the date of acceptance of the work under the Contract, by reason of defects in workmanship or materials used in construction of said work; and

B. To remedy any and all defects that may develop in or result from new paving work to be performed under the Contract within the period of (4) years from the date of acceptance of the work under the Contract, by reason of defects in workmanship or materials used in construction of said work;

C. To keep all work in continuous good repair; and

D. To pay the Jurisdiction's reasonable costs of monitoring and inspection to assure that any defects are remedied, and to repay the Jurisdiction all outlay and expense incurred as a result of Contractor's and Surety's failure to remedy any defect as required by this section.

E. Maintenance bond requirements shall not apply to the following: work that is not permanently incorporated into the project, pavement markings, seeding, sodding, and plant material and planting.

4. GENERAL: Every Surety on this Bond shall be deemed and held bound, any contract to the contrary notwithstanding, to the following provisions:

A. To consent without notice to any extension of time to the Contractor in which to perform the Contract;

B. To consent without notice to any change in the Contract or Contract Documents, which thereby increases the total contract price and the penal sum of this bond, provided that all such changes do not, in the aggregate, involve an increase of more than 20% of the total contract price, and that this bond shall then be released as to such excess increase; and

C. To consent without notice that this Bond shall remain in full force and effect until the Contract is completed, whether completed within the specified contract period, within an extension thereof, or within a period of time after the contract period has elapsed and the liquidated damage penalty is being charged against the Contractor.

D. That no provision of this Bond or of any other contract shall be valid that limits to less than five years after the acceptance of the work under the Contract the right to sue on this Bond.

E. That as used herein, the phrase "all outlay and expense" is not to be limited in any way, but shall include the actual and reasonable costs and expenses incurred by the Jurisdiction including interest, benefits, and overhead where applicable. Accordingly, "all outlay and expense" would include but not be limited to all contract or employee expense, all equipment usage or rental, materials, testing, outside experts, attorneys fees (including overhead expenses of the Jurisdiction's staff attorneys), and all costs and expenses of litigation as they are incurred by the Jurisdiction. It is intended the Contractor and Surety will defend and indemnify the Jurisdiction on all claims made against the

SUDAS PERFORMANCE,  
PAYMENT AND MAINTENANCE  
BOND

Jurisdiction on account of Contractor's failure to perform as required in the Contract and Contract Documents, that all agreements and promises set forth in the Contract and Contract Documents, in approved change orders, and in this Bond will be fulfilled, and that the Jurisdiction will be fully indemnified so that it will be put into the position it would have been in had the Contract been performed in the first instance as required.

In the event the Jurisdiction incurs any "outlay and expense" in defending itself against any claim as to which the Contractor or Surety should have provided the defense, or in the enforcement of the promises given by the Contractor in the Contract, Contract Documents, or approved change orders, or in the enforcement of the promises given by the Contractor and Surety in this Bond, the Contractor and Surety agree that they will make the Jurisdiction whole for all such outlay and expense, provided that the Surety's obligation under this bond shall not exceed 125% of the penal sum of this bond.

In the event that any actions or proceedings are initiated regarding this Bond, the parties agree that the venue thereof shall be Washington County, State of Iowa. If legal action is required by the Jurisdiction to enforce the provisions of this Bond or to collect the monetary obligation incurring to the benefit of the Jurisdiction, the Contractor and the Surety agree, jointly, and severally, to pay the Jurisdiction all outlay and expense incurred therefor by the Jurisdiction. All rights, powers, and remedies of the Jurisdiction hereunder shall be cumulative and not alternative and shall be in addition to all rights, powers, and remedies given to the Jurisdiction, by law. The Jurisdiction may proceed against surety for any amount guaranteed hereunder whether action is brought against the Contractor or whether Contractor is joined in any such action(s) or not.

NOW THEREFORE, the condition of this obligation is such that if said Principal shall faithfully perform all the promises of the Principal, as set forth and provided in the Contract, in the Contract Documents, and in this Bond, then this obligation shall be null and void, otherwise it shall remain in full force and effect.

When a word, term, or phrase is used in this Bond, it shall be interpreted or construed first as defined in this Bond, the Contract, or the Contract Documents; second, if not defined in the Bond, Contract, or Contract Documents, it shall be interpreted or construed as defined in applicable provisions of the Iowa Code; third, if not defined in the Iowa Code, it shall be interpreted or construed according to its generally accepted meaning in the construction industry; and fourth, if it has no generally accepted meaning in the construction industry, it shall be interpreted or construed according to its common or customary usage.

Failure to specify or particularize shall not exclude terms or provisions not mentioned and shall not limit liability hereunder. The Contract and Contract Documents are hereby made a part of this Bond.

**(CON'T – PERFORMANCE, PAYMENT, AND MAINTENANCE BOND)**

**PRINCIPAL**

CONTRACTOR: \_\_\_\_\_

SIGNATURE:

\_\_\_\_\_

TITLE: \_\_\_\_\_

**SURETY**

SURETY COMPANY: \_\_\_\_\_

SIGNATURE ATTORNEY-IN-FACT/OFFICER:

\_\_\_\_\_

PRINTED ATTORNEY-IN-FACT/OFFICER:

\_\_\_\_\_

ADDRESS: \_\_\_\_\_

TELEPHONE: \_\_\_\_\_

**FORM APPROVED BY**

ATTORNEY FOR JURISDICTION:

\_\_\_\_\_

**NOTE:**

1. All signatures on this performance, payment, and maintenance bond must be original signatures in ink; copies, facsimile, or electronic signatures will not be accepted.
2. This bond must be sealed with the Surety's raised, embossing seal.
3. The Certificate or Power of Attorney accompanying this bond must be valid on its face and sealed with the Surety's raised, embossing seal.
4. The name and signature of the Surety's Attorney-in-Fact/Officer entered on this bond must be exactly as listed on the Certificate or Power of Attorney accompanying this bond.

**END OF SECTION**



**SECTION 00 7200  
GENERAL CONDITIONS**

**FORM OF GENERAL CONDITIONS**

**1.1 THE GENERAL CONDITIONS APPLICABLE TO THIS CONTRACT ARE AS FOLLOWS:**

- A. Iowa Statewide Urban Design and Specification (SUDAS), 2022 Edition, shall apply and be used as specifications for this project.
- B. Insurance by Contractor
  - 1. The Contractor must provide a certificate of insurance showing coverage in the required amounts prior to project commencement and throughout the construction period with the following minimum amounts:
    - a. Workmen's compensation and occupational disease insurance in accordance with the laws of the State of Iowa covering all employees who perform any obligations assumed under the contract.
    - b. Public liability and property damage liability insurance covering all operations under the contract; limits of bodily injury or death and property damage of \$1,000,000 for each accident; and \$1,000,000 aggregate for accidents during the policy period on a per project basis. The Owner and Engineer shall be named additional insured on the Contractor's insurance.
    - c. Automobile liability insurance on all self-propelled vehicles used in connection with the contract, whether owned, non-owned, or hired; public liability limits of not less than \$500,000 for one person and \$1,000,000 for each accident; property damage limit of \$500,000 for each accident.
  - 2. Owner reserves the right to approve the insurance company.
- C. Construction Staking
  - 1. Staking services, as requested by the Contractor, will be provided by Axiom Consultants and contracted between Axiom Consultants and the City of Riverside.
- D. Scheduling
  - 1. The Contractor shall provide a proposed schedule upon award of contract and in preparation of pre-construction meeting.
- E. Electronic Media Transfer
  - 1. The Electronic Release Form, following this section is required for any request of electronic or CAD files regarding this project: City of Riverside: Hall Park Boat Ramp Phase I.

**END OF SECTION**

# DRAWINGS FOR PROPOSED IMPROVEMENTS HALL PARK BOAT RAMP PHASE 1 RIVERSIDE, WASHINGTON COUNTY, IOWA

## LEGAL DESCRIPTION

17 77 06 LOT B SD PT W1/2 NW1/4

## DESIGN STANDARDS AND REFERENCE DRAWINGS

THE PROPOSED IMPROVEMENTS INCLUDED IN THESE DRAWINGS HAVE BEEN DESIGNED IN ACCORDANCE WITH THE CITY OF CEDAR RAPIDS COMPLETE STREET DESIGN STANDARDS OF 2014 AND THE IOWA STATEWIDE URBAN DESIGN AND SPECIFICATIONS (SUDAS), LATEST ADDITION, UNLESS NOTED OTHERWISE ON THE PLANS.

THE FOLLOWING DESIGN EXCEPTIONS ARE REQUIRED: CEDAR RAPIDS SUPPLEMENTAL DOCUMENTS.

THE FOLLOWING SUDAS FIGURES ARE INCLUDED BY REFERENCE:

FIGURE	TITLE
3010.101	TRENCH BEDDING AND BACKFILL ZONES
3010.102	RIGID GRAVITY PIPE TRENCH BEDDING
3010.103	FLEXIBLE GRAVITY PIPE TRENCH BEDDING
4020.211	PIPE CONNECTIONS FOR STORM SEWER
4030.221	RCP APRON SECTION FOOTING
4030.222	CIRCULAR CONCRETE APRONS
9040.102	FILTER BERM AND FILTER SOCK
9040.103	ROLLED EROSION CONTROL PRODUCT (RECP) INSTALLATION ON SLOPES
9040.119	SILT FENCE
9040.110	RIP RAP FOR PIPE OUTLET ONTO FLAT GROUND
9040.120	STABILIZED CONSTRUCTION ENTRANCE

## SITE INFORMATION

**EXISTING ZONING**  
P-1 PUBLIC USE DISTRICT

**AREA CALCULATIONS**  
TOTAL LOT SIZE: 120,661 SF (2.77 AC)

**EXISTING:**  
OPEN SPACE 120,661 SF (2.77 AC) 100.0%

**SETBACKS:**  
NONE

## LOCATION MAP

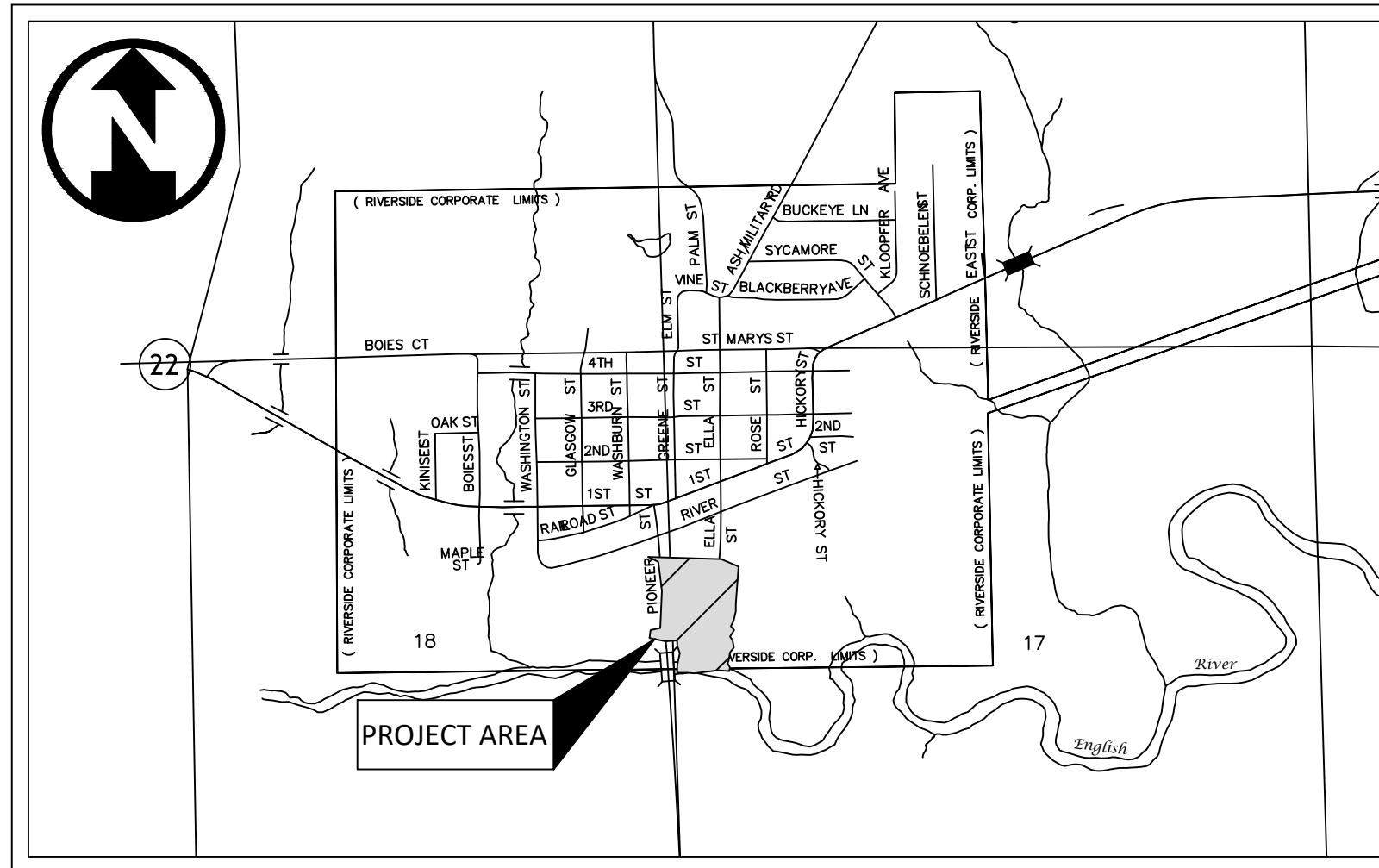

CITY OF CEDAR RAPIDS

SHEET INDEX		REV
C0.00	COVER SHEET	
C1.00	EXISTING CONDITIONS AND REMOVALS PLAN	
C2.00	SITE PLAN	
C3.00	TRAFFIC CONTROL	
C4.00	CONSTRUCTION DETAILS	

## PROJECT INFORMATION

### CONTACT PERSON:

BRIAN BOELK  
AXIOM CONSULTANTS, LLC  
60 E COURT STREET, UNIT 3  
IOWA CITY, IOWA 52240-3833  
PHONE: 319-519-6220  
BBOELK@AXIOM-CON.COM

### CITY CONTACT

COLE SMITH  
CITY ADMINISTRATOR  
PHONE: 319-648-3501  
CITYADMIN@RIVERSIDEIOWA.GOV



## UTILITY CONTACTS

**ALLIANT ENERGY**  
ALLIANT ENERGY FIELD ENGINEER  
800-255-4268  
LOCATE\_IPL@ALLIANTENERGY.COM

**PEOPLE SERVICE, INC**  
STEVE ROBINETTE  
319-800-3281  
SROBINETTE@PEOPLESERVICE.COM

**CITY OF RIVERSIDE**  
BECKY LAROCHE  
319-648-3501  
BECKY@CITYOFRIVERSIDEIOWA.COM

**MIDAMERICAN-GAS**  
CARSON HEMPHILL  
319-341-4461  
CRHEMPHILL@MIDAMERICAN.COM

**MEDIACOM**  
CARL NORTON  
319-594-6201  
CNORTON@MEDIACOMCC.COM

**WINDSTREAM COMMUNICATIONS**  
LOCATE DESK  
800-289-1901  
LOCATE.DESK@WINDSTREAM.COM

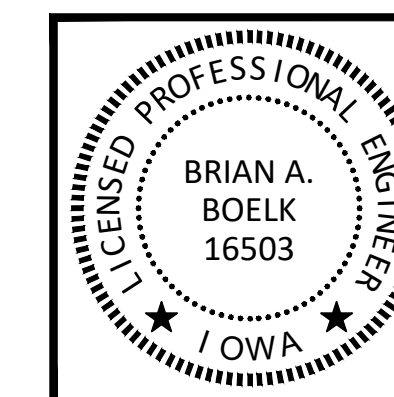

I HEREBY CERTIFY THAT THIS ENGINEERING DOCUMENT WAS PREPARED BY ME OR UNDER MY DIRECT PERSONAL SUPERVISION AND THAT I AM A DULY LICENSED PROFESSIONAL ENGINEER UNDER THE LAWS OF THE STATE OF IOWA.

BRIAN A. BOELK, P.E.  
LICENSE NUMBER 16503.

MY LICENSE RENEWAL DATE IS DECEMBER 31, 2024.

PAGES OR SHEETS COVERED BY THIS SEAL: ALL



ENGINEER:

**DRAWING LOG**  
DESCRIPTION OF CHANGES  
CITY COUNCIL APPROVAL

DATE  
12-22-2023

REV  
1

PROJECT NAME:  
RIVERSIDE BOAT RAMP  
S PIONEER ST  
RIVERSIDE, IA  
CLIENT NAME:

SHEET NAME:  
COVER SHEET  
SHEET NUMBER:  
230149  
DESIGNED, DETAILED, AND CHECKED BY:  
BETTIS

NOT FOR CONSTRUCTION

C0.00

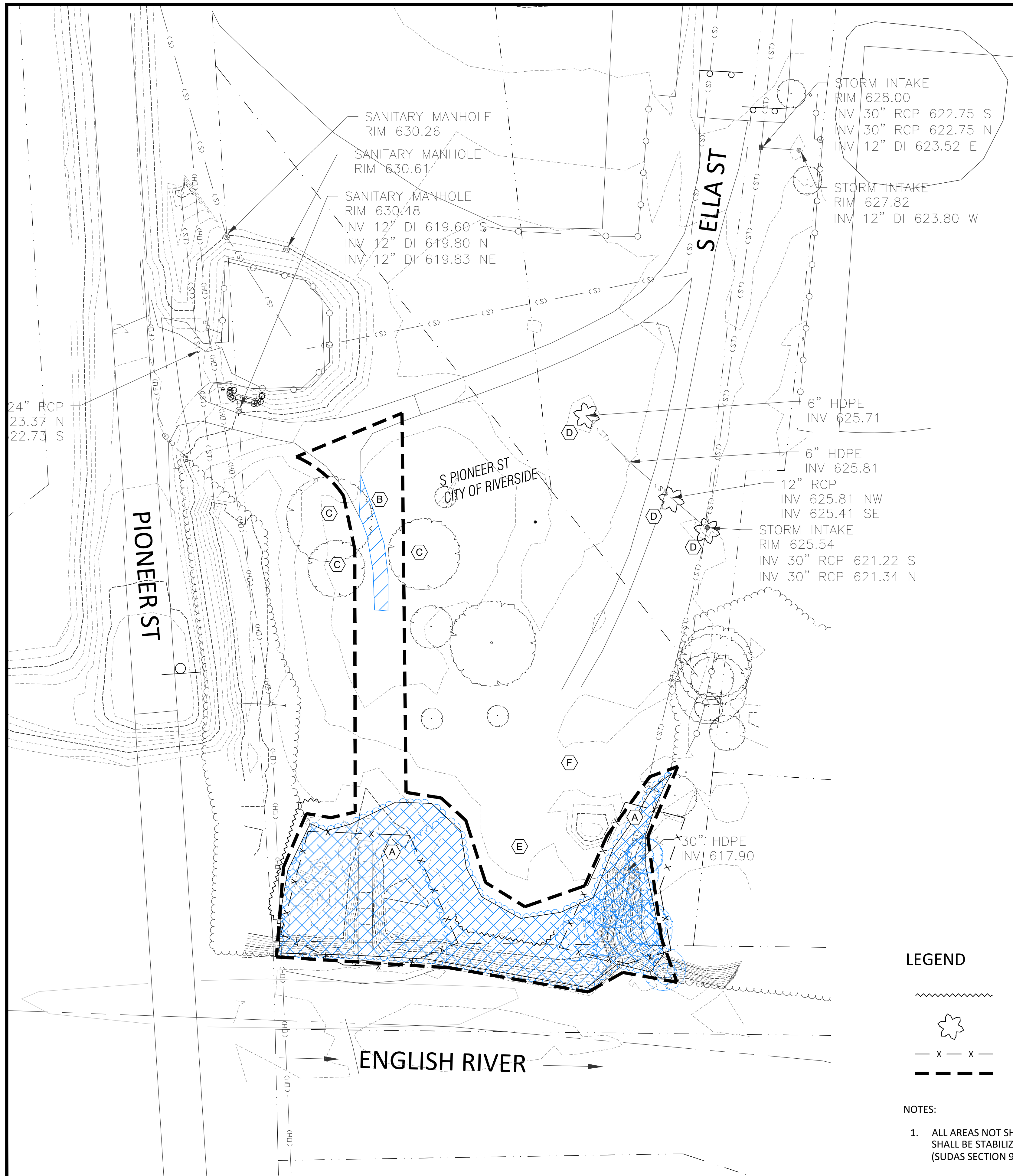

**DEMOLITION NOTES:**

- (A) AREA TO BE CLEARED OF TREES/SHRUBS
- (B) EXISTING ROCK DRIVE REMOVAL AREA
- (C) PROTECT TREE. SEE DETAIL 1, THIS PAGE.
- (D) INLET PROTECTION
- (E) STOCKPILE AREA
- (F) LAYDOWN AREA

**LEGEND**

- 9" FILTER SOCK-INSTALL UPON COMPLETION OF FINISH GRADING
- INLET PROTECTION PER IDOT EC-602
- GRADING LIMITS
- DISTURBED AREA

- NOTES:**
- ALL AREAS NOT SHOWN AS PAVEMENT OR PERMANENT SEEDING SHALL BE STABILIZED WITH TEMPORARY SEEDING (SUDAS SECTION 9010 TYPE 4 MIX)

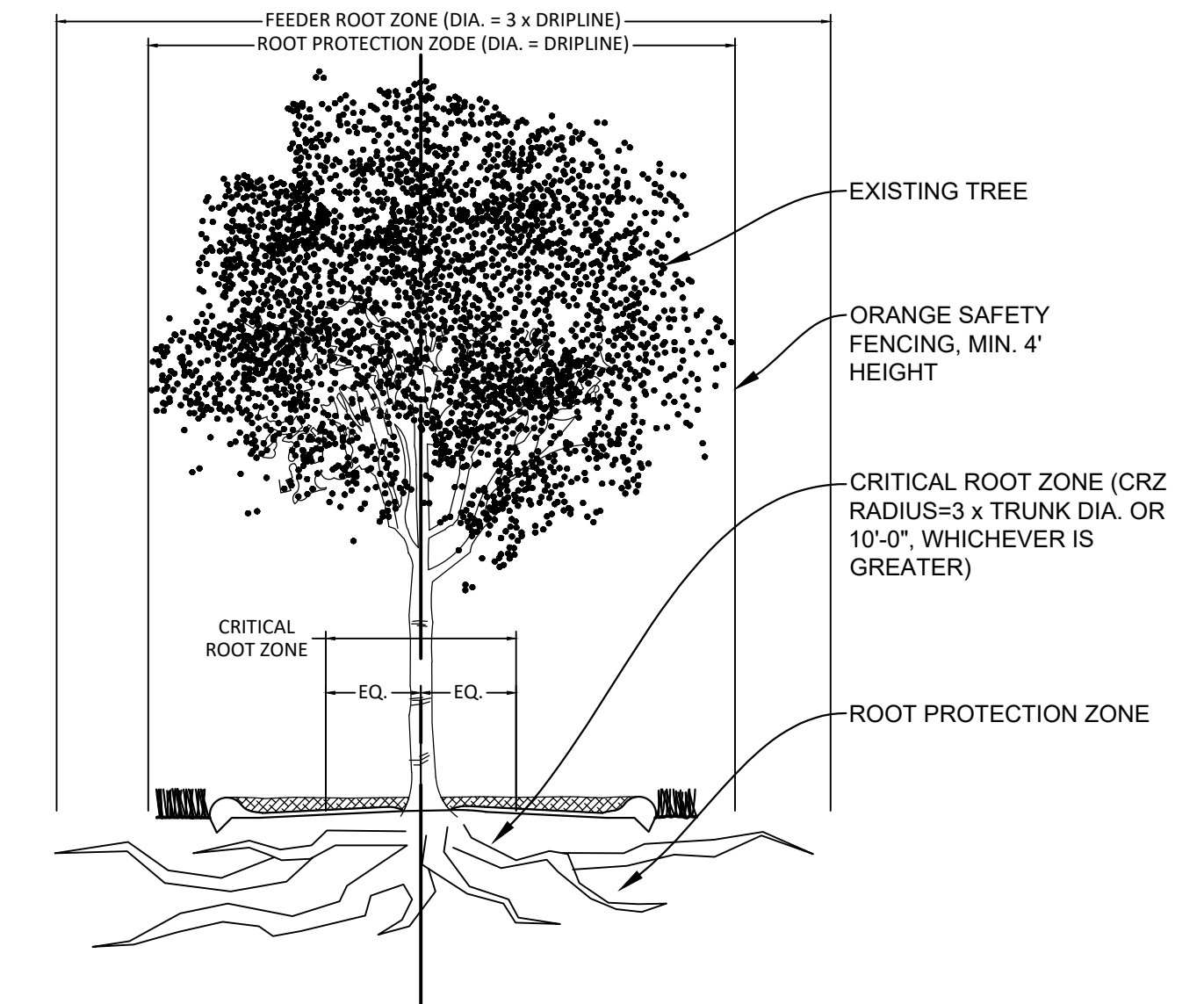

**TREE PROTECTION NOTES:**

- MIN. 4'-0" HEIGHT ORANGE SAFETY FENCING SHALL BE PROVIDED AND MAINTAINED AT DRIPLINE.
- NO DISTURBANCE ALLOWED WITHIN CRITICAL ROOT ZONE (CRZ).
- OPERATION OF HEAVY EQUIPMENT AND/OR STOCKPILING OF MATERIALS IS PROHIBITED WITHIN THE ROOT PROTECTION ZONE (RPZ).
- DIAMETER AT BREAST HEIGHT (DBH) IS MEASURED AT 4'-6" ABOVE GRADE.

TREE PROTECTION  
NTS

1

**NOT FOR CONSTRUCTION**

**EXISTING CONDITIONS AND REMOVALS PLAN**

PROJECT NAME: RIVERSIDE BOAT RAMP  
S PIONEER ST  
RIVERSIDE, IA

CLIENT NAME: BETTIS

PROJECT NO.: 230149

DESIGNED, DETAILED, AND CHECKED BY: BETTIS

SHEET NO.: 1

SHEET NUMBER: C1.00

DRAWING LOG

REV	DESCRIPTION OF CHANGES	DATE
1	CITY COUNCIL APPROVAL	12-22-2023

ENGINEER: **AXIOM CONSULTANTS**  
WWW.AXIOM-CON.COM | (319) 519-6220

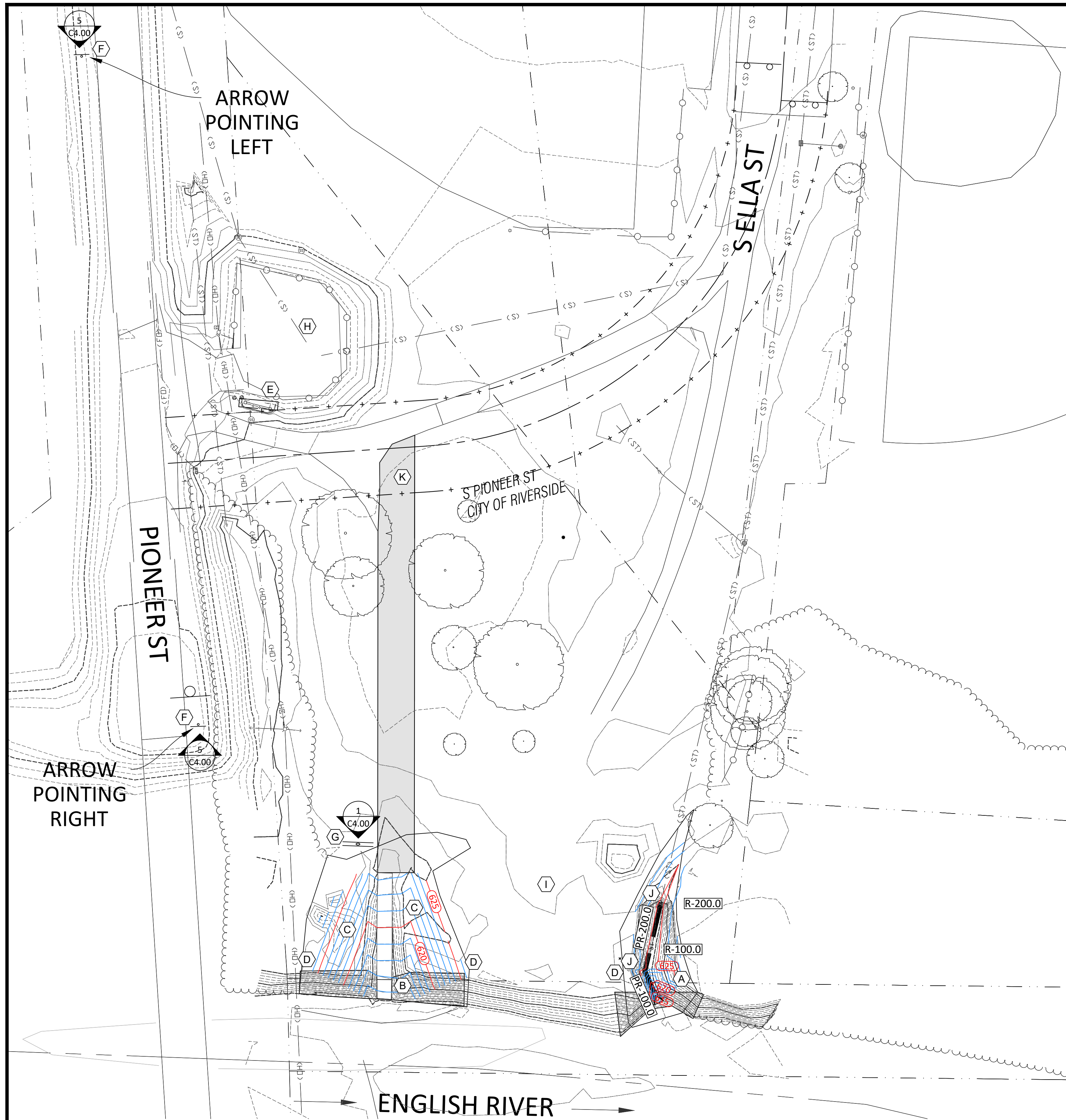

**KEYNOTES**

- (A) TREE REMOVAL AND GRADING OF SWALE FOR STORM SEWER PIPE OUTLET
- (B) POSSIBLE END OF RAMP FIX OR EXTENSION
- (C) TREE REMOVAL AND GRADING TO ALLOW FOR FUTURE RAMP WIDENING
- (D) EROSION CONTROL ALONG ENGLISH RIVER AND OR CHANNEL.
- (E) PROTECT EXISTING CITY OF RIVERSIDE SIGN
- (F) WAY MARKING SIGN
- (G) RIVER CORRIDOR SIGNAGE
- (H) EXISTING CITY LIFT STATION
- (I) FUTURE PAVILION AND OPEN SPACE SITE AMENITIES
- (J) STORM STRUCTURE
- (K) ROCKED PAVEMENT

STORM SEWER STRUCTURES				
STRUCTURE ID	TYPE	RIM / FG	INFLOW PIPE IE	OUTFLOW PIPE IE
36" FES W/ TOE WALL	FES	619.22		36" IE: 615.71 NW
100.0	SW-401 60" DIA.	624.32	36" IE: 616.00 SE	36" IE: 616.10 N
200.0	SW-401 60" DIA.	624.72	36" IE: 617.00 S	

STORM SEWER PIPE TABLE								
PIPE ID	STRUCTURE US	STRUCTURE DS	INVERT US	INVERT DS	LENGTH (FEET)	SLOPE	SIZE (IN)	MATERIAL
100.0	36" FES W/ TOE WALL	100.0	615.71	616.00	15	-2.00%	36	HDPE
200.0	100.0	200.0	616.10	617.00	45	-2.00%	36	HDPE

DRAWING LOG	
REV	DATE
1	12-22-2023
DESCRIPTION OF CHANGES CITY COUNCIL APPROVAL	

PROJECT NAME: RIVERSIDE BOAT RAMP S PIONEER ST RIVERSIDE, IA	CLIENT NAME: BETTIS
---	------------------------

SHEET NO.: 230149	DESIGNED, DETAILED, AND CHECKED BY: BETTIS
----------------------	---

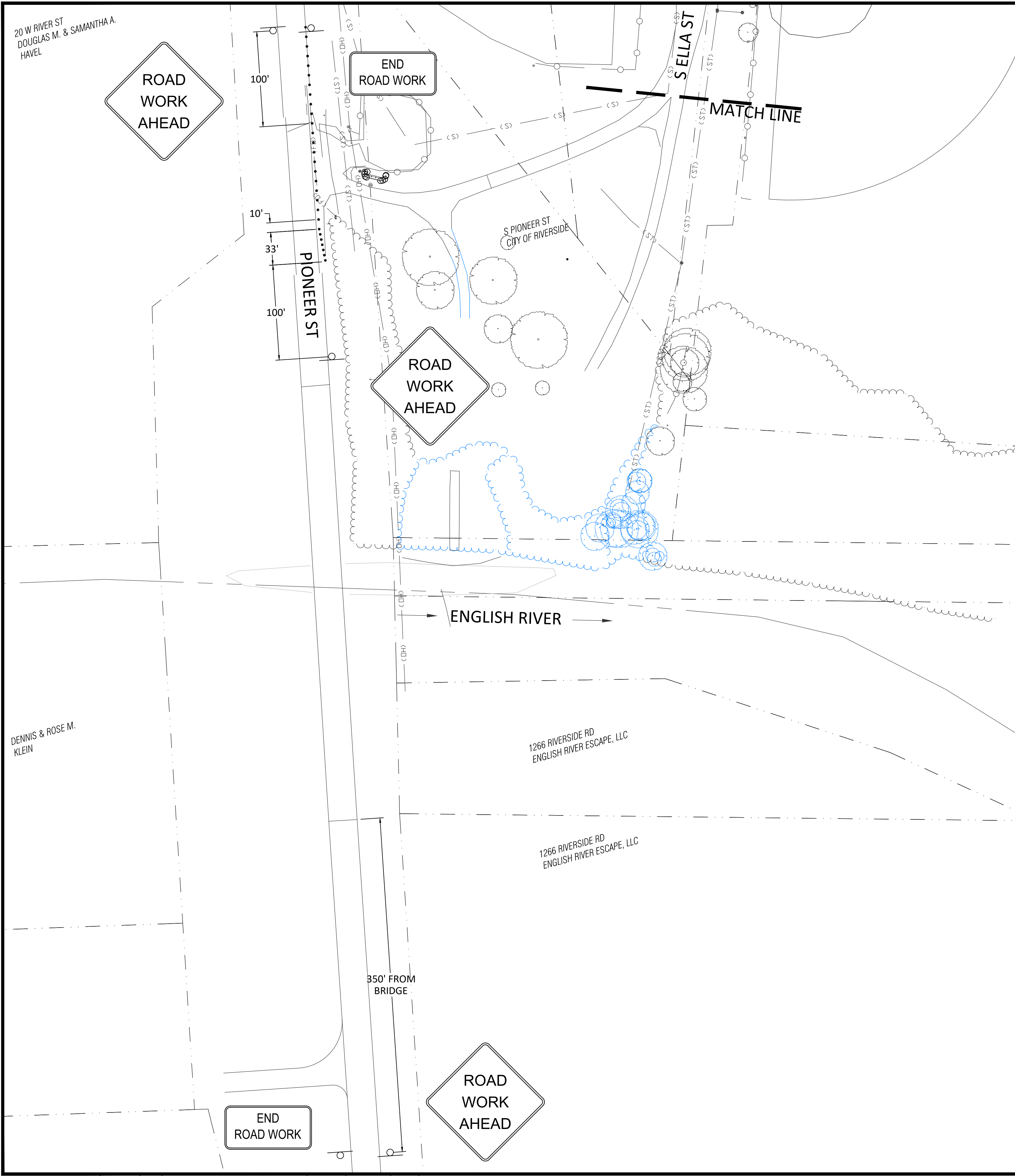

**TRAFFIC CONTROL NOTES:**

- TEMPORARY TRAFFIC CONTROL SIGN
- ⊗ CHANNELIZER

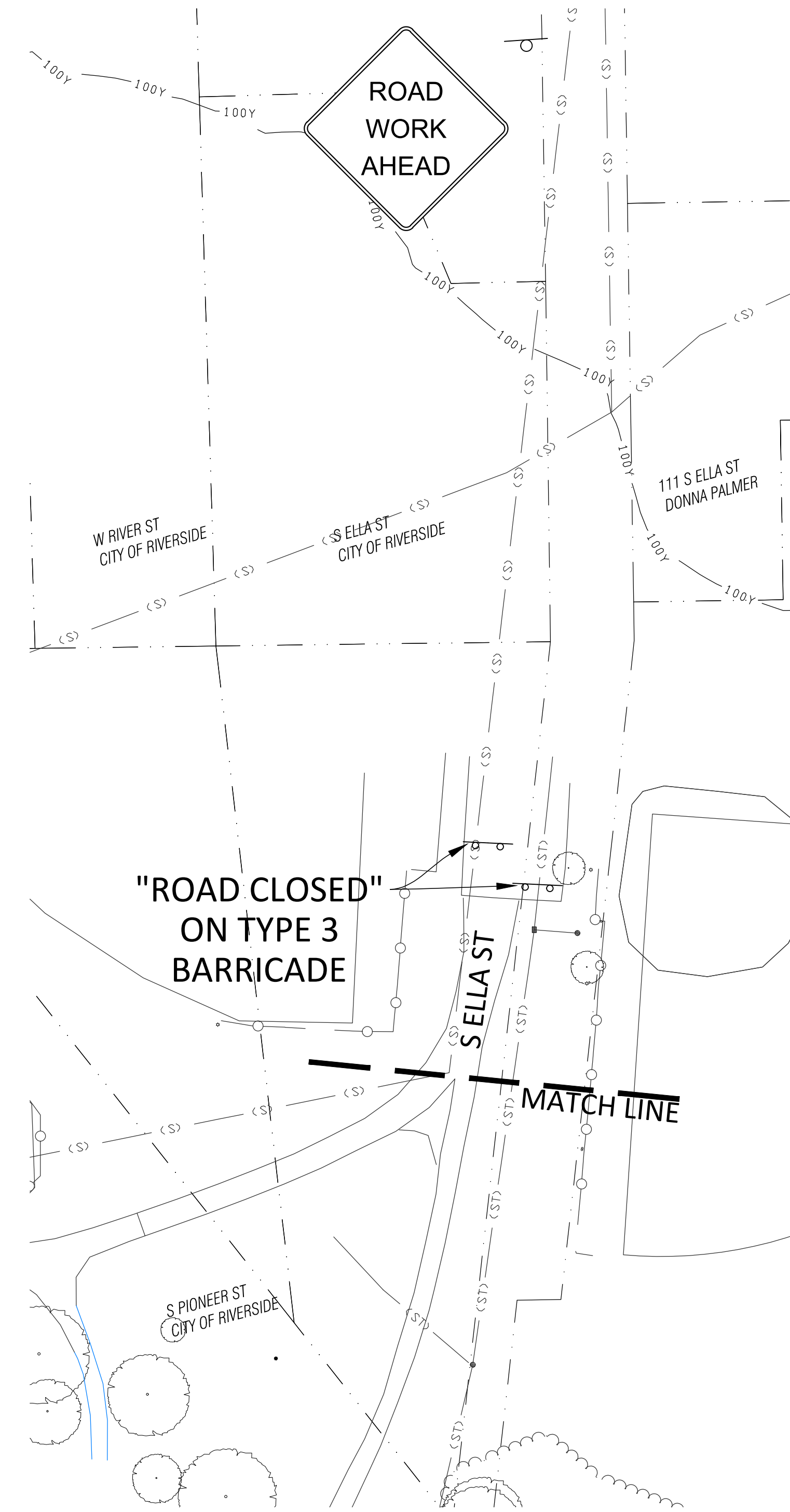

**NOT FOR CONSTRUCTION**

SHEET NAME:  
**TRAFFIC CONTROL**

SHEET NO.:  
**230149**

SHEET NUMBER:  
**C3.00**

DESIGNED, DETAILED, AND CHECKED BY:  
**BETTIS**

PROJECT NAME:  
**RIVERSIDE BOAT RAMP**

**S PIONEER ST**  
**RIVERSIDE, IA**

CLIENT NAME:

DRAWING LOG	
REV	DATE
1	12-22-2023
DESCRIPTION OF CHANGES CITY COUNCIL APPROVAL	

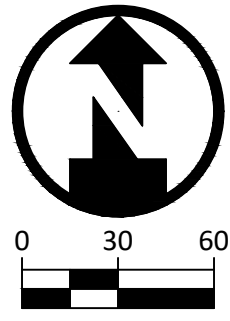

ENGINEER:  
**AXIOM**  
**CONSULTANTS**

WWW.AXIOM-CON.COM | (319) 519-6220

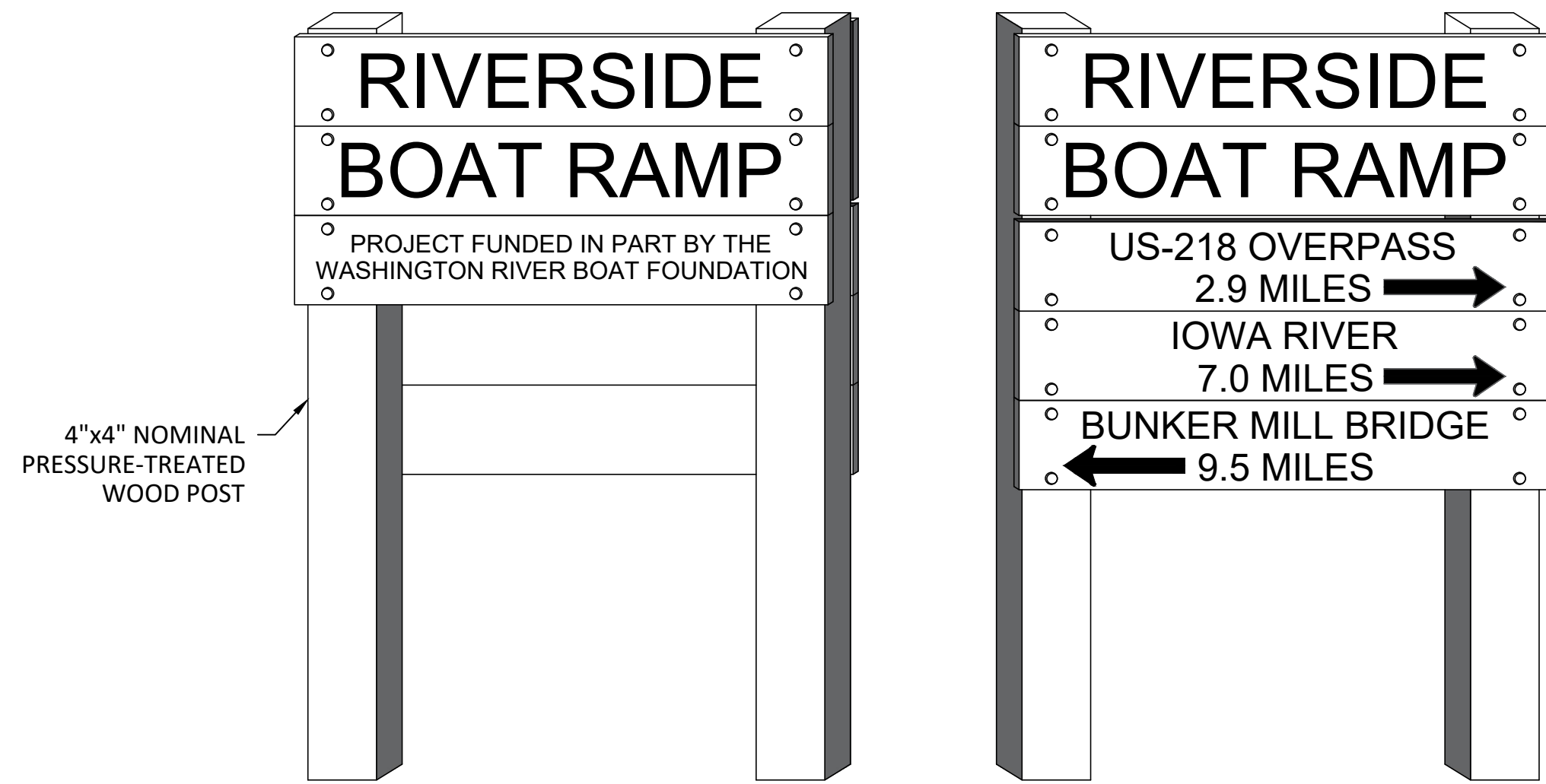

### BOAT RAMP SIGN

FRONT(LEFT) & BACK(RIGHT)  
NTS

1

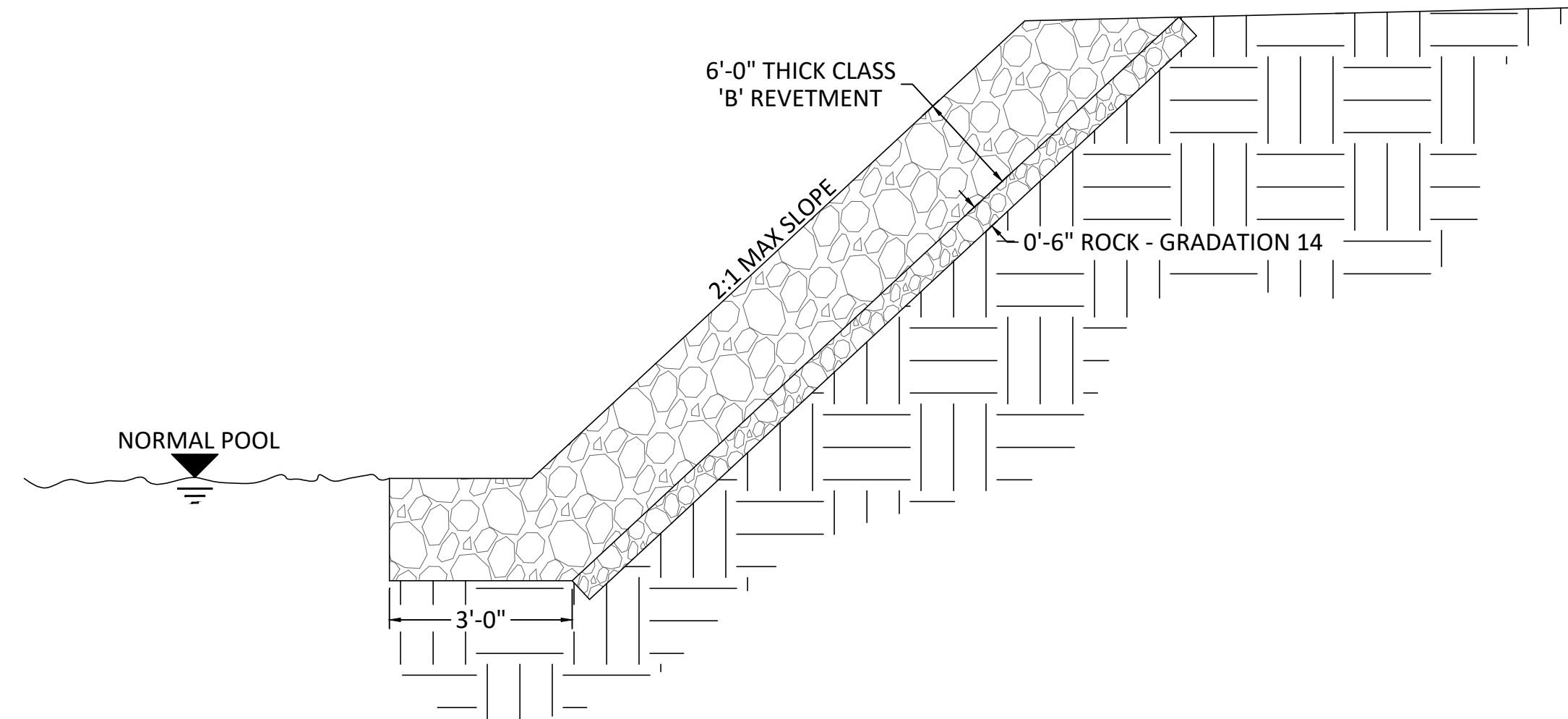

### EROSION CONTROL REVETMENT

NTS

2

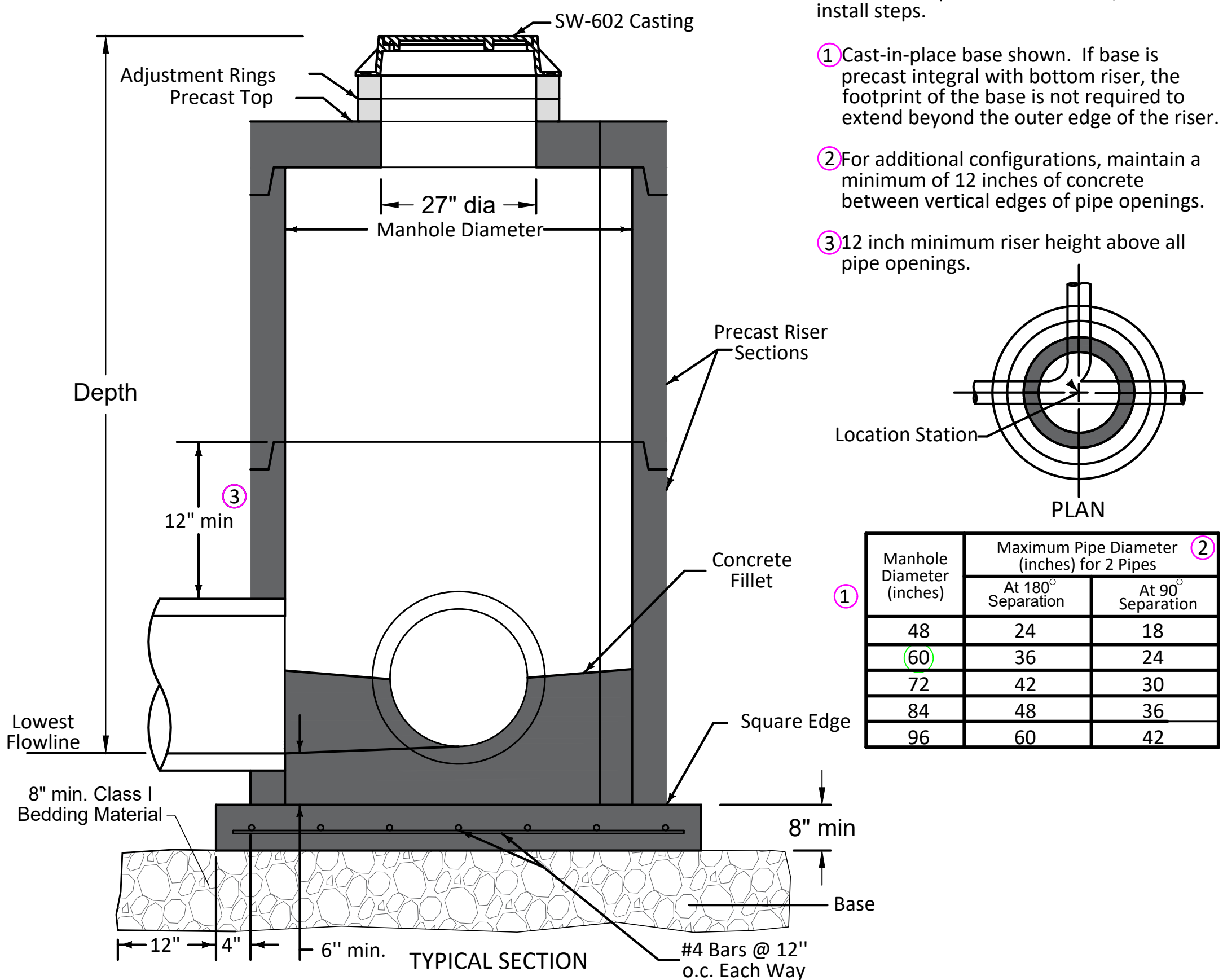

### CIRCULAR STORM SEWER MANHOLE

SW-401  
NTS

3

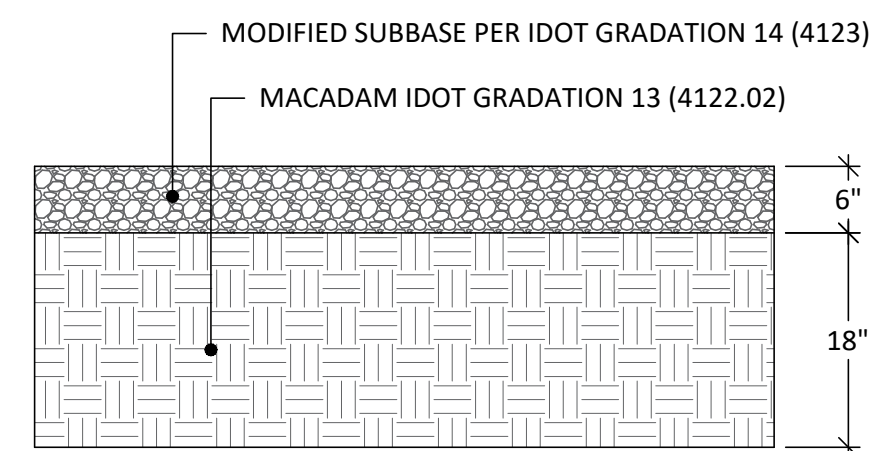

### ROCKED PAVEMENT SECTION

NTS

4

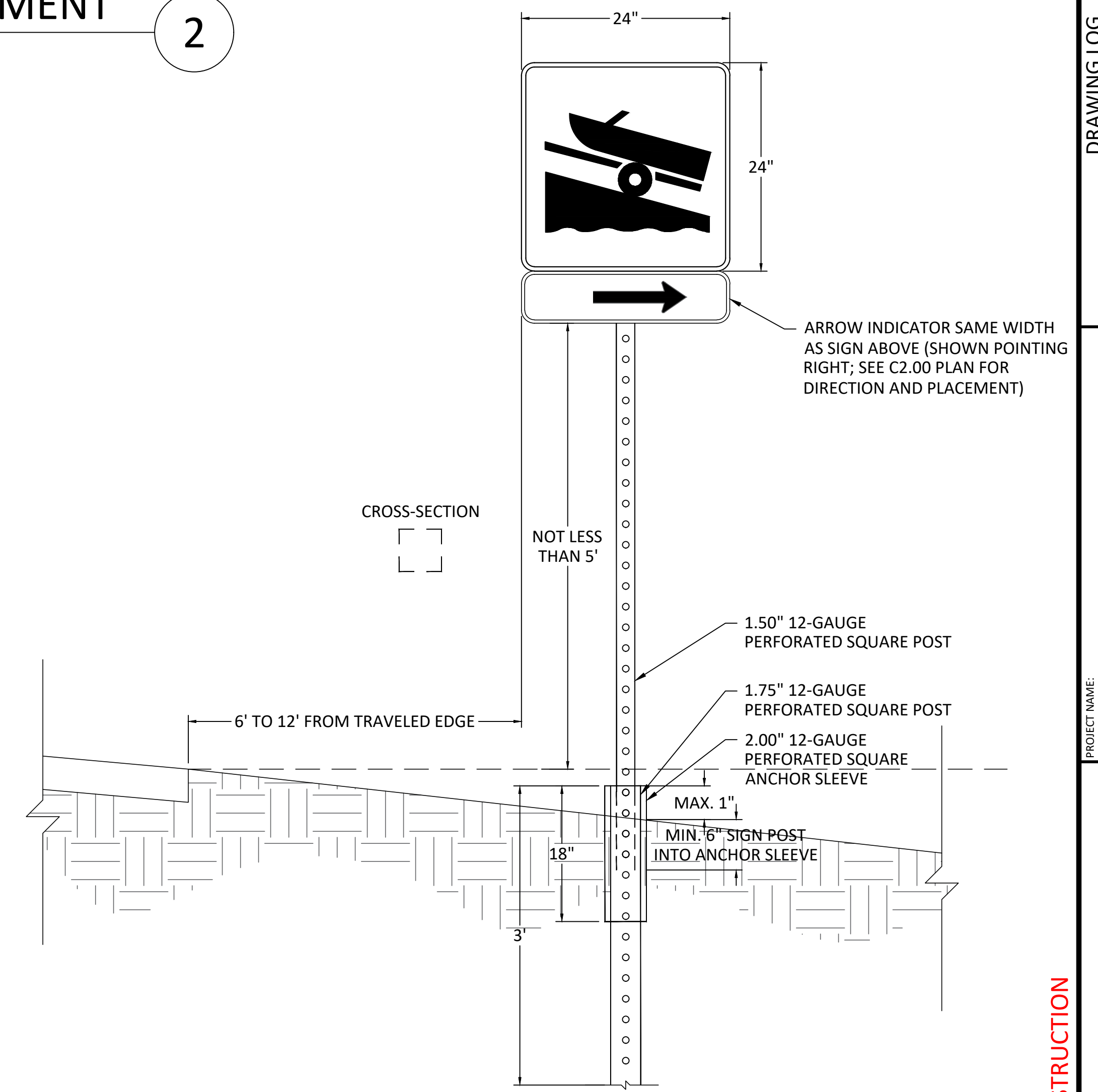

### 24"x24" BREAKAWAY SIGN DETAIL

MUTCD RS-054  
NTS

5

DRAWING LOG

REV	DATE	DESCRIPTION OF CHANGES
1	12-22-2023	CITY COUNCIL APPROVAL

PROJECT NAME:  
RIVERSIDE BOAT RAMP  
S PIONEER ST  
RIVERSIDE, IA  
CLIENT NAME:

SHEET NAME:  
CONSTRUCTION DETAILS  
DESIGNED, DETAILED, AND CHECKED BY:  
BETTIS

PROJECT NO.:  
230149

SHEET NUMBER:

C4.00

NOT FOR CONSTRUCTION