

RIVERSIDE, IA CITY COUNCIL MEETING AGENDA
DATE: MONDAY, AUGUST 21, 2017
LOCATION: COUNCIL CHAMBERS, CITY HALL (60 N GREENE STREET)

MEETING TIME: 6:30 PM

1. Call meeting to order
2. Pledge of Allegiance
3. Roll call
4. Approval of agenda
5. Consent agenda
 - a. Minutes from 08-07-2017
 - b. Expenditures 08-21-2017
 - c. Riverside Travel Mart alcohol permit
6. Citizen comments
 - a. Public Forum – This time is allowed for public comments. The City Council will not be able to take action on any item not on the agenda. The City Council can choose to add the topic to a future agenda for consideration. This is intended to be the only public comment period (other than public hearings) on the agenda. The City Council may agree to allow public comments during an agenda item if they deem it appropriate. Time is limited to 3 minutes per person.
 - b. Discussion and action on Jeff Showalter's request for reimbursement for cleanup due to 2nd Street construction. 8
 - c. Discussion and action on Brad Fuhrmann's letter regarding property cleanup. 17
7. Committee reports
8. Discussion and action on Washington Economic Development Group's request to increase our annual pledge. (Raber)
9. MMS Consultants report (Meisner)
 - a. Discussion of Washburn and 2nd Street project 24
 - i. Update on status of SWPP reports and DNR complaint
 - ii. Update on compliance with ADA requirements for building entrances
 - b. Discussion of Pioneer and Highway 22 design project 30
 - c. Discussion of Cherry Lane ADA sidewalk to community mailbox
 - d. Discussion of flood plain permit for Hall Park
 - e. Discussion and action on Pay Request #4 for Dave Schmitt Construction in the amount of \$262,765.29. The project is 79% complete. Resolution 082117-01. 32
10. PeopleService monthly report (Stukey) 37
 - a. Discussion of monthly report
 - b. Report on Visu-Sewer sewer cleaning 45
 - c. Discussion and action on Omnisite monitoring service for lift stations 1, 2 and 4 and water and wastewater plants 51
 - d. Discussion and action on membrane replacement 55
 - e. Discussion and action on Cummins generator preventative maintenance visit and service needs for generators at lift stations 1 and 5 57
11. New Business
 - a. Discussion and action on property at 99 1st Street. (Pickering) 65

RIVERSIDE, IA CITY COUNCIL MEETING AGENDA
DATE: MONDAY, AUGUST 21, 2017
LOCATION: COUNCIL CHAMBERS, CITY HALL (60 N GREENE STREET)

- b. Discussion and action on Mayor's request to move Jay Stuelke from part-time to full-time. Resolution 082117-02. 77
- 12. Old Business
 - a. Discussion and action on agreement with iTech to provide computer maintenance services 79
 - b. Discussion of Habitat for Humanity house build
 - c. Discussion and action on employee review schedule and review process 80
- 13. Other Business
 - a. Set a date for the first regular meeting in September
 - b. Reminder of Fall Cleanup Day – September 9th
 - c. Johnson County Refuse response to Kevin Mills' request from 08-07-17
 - d. Councilmembers' comments and requests for information
- 14. Adjournment

Allen Schneider

Allen Schneider, Mayor

RIVERSIDE CITY COUNCIL MEETING: August 7th, 2017

The Riverside City Council held a work session at 5:30 pm to discuss Pioneer Street Drainage and the Northern Growth Development.

The regular Riverside City Council meeting opened at 6:35 pm in City Hall with Mayor Allen Schneider requesting roll call. Council members present were: Bob Schneider Jr., Jeanine Redlinger, Tom Sexton, Rob Weber, and Ralph Schnoebelen.

Motion by Schneider to approve the agenda. Second by Schnoebelen, passed 5-0.

Schneider moved to approve the minutes from July 17th , and 8-7-17 Expenditures, pulling iTech, PJ Greufe, Visu Sewer, Lory Young, and Kalonial Lawn Care for further discussion. Second by Sexton, passed 5-0. Schneider moved to pay pulled bills except for PJ Greufe. Clerk will ask for update on HR project. Second by Schnoebelen, passed 5-0.

Kevin Meller reported on Trekfest. Requested improvements in park for next year, including upgrade of electrical power, and sound proofing metal stage roof. Meller discussed having additional summer concerts in the park.

Citizens Comments: Kevin Mills addressed council on water issues on his property. Larry Simon asked Council when they were going to address Ella Street problems. Mayor Schneider replied that they would address the issues of homeowners as they bring them to the council.

Katie Schneider of the Riverside Ball Association presented Hotel/Motel grant application to council. Weber moved to approve the \$500 grant. Second by Redlinger, passed 4-1 Sexton opposed.

Glen Meisner, Scott Pottorff, and Ben Mitchel of MMS Consultants discussed updates on Washburn and 2nd street project, alley behind Murphy's, Mill's water issue, and Cherry Lane ADA sidewalk.

Schnoebelen moved to replace the west Hwy 22 sidewalk as planned. Homeowners will be responsible for any deficiencies in foundations. Second by Weber, passed 5-0.

Schnoebelen moved to combine Pioneer Street and the East and West sidewalks of the Hwy 22 project, with the St. Mary's street water main into one project to be bid in January 2018. Second by Redlinger, passed 5-0. Construction would be from March to September 2018.

Sexton moved to enter into Closed Session pursuant to Iowa Code Section 21.5(1)(j) Real Estate at 8:32 pm. Second by Weber, passed 5-0.

Sexton moved to return to open meeting at 8:58 pm.

Redlinger moved to have MMS proceed as discussed. Second by Schneider, passed 5-0.

Bryan Lenz reviewed city ditches with Sexton and Schneider.

Schnoebelen moved to increase City Employee Stuelke to 40 hours per week for 30 days to work on ditches using a backhoe from Schnoebelen Inc. as needed. Second by Schneider, passed 5-0.

Kevin Mills addressed council about recent re-cycling issues. Clerk will obtain a list of regulations from Johnson County Refuse.

KCTC Computer Maintenance contract was reviewed by Council. Schneider requested that changes be made to include cost and number of years of contract.

Discussion held on Solar Companies. Brian Fleming of Precision Energy Services was in attendance to update council on his proposal. Mayor Schneider is still collecting information on other companies.

Habit for Humanity House is in progress. Volunteers can help on Wednesday and Thursdays in August. Call City Hall to schedule work time.

The State Bike Race will be in Riverside on Saturday, August 19th. Bryan will set out road barricades for their use.

Placement of the west side welcome sign was confirmed. City needs to prepare agreement.

Council discussed testing the water flow on Ella Street.

Schnoebelen moved to adjourn meeting at 10:11 pm. Second by Sexton, passed 5-0.

Full content of Council Meetings can be viewed on the City web site;
www.cityofriversideiowa.com

Council Meeting – Monday, August 21, 2017 at 6:30 pm

ATTEST:



Lory Young, City Clerk



Allen Schneider, Mayor

EXPENDITURES 8-21-17					
COUNCIL MEETING					
	UNPAID BILLS				
BIG IRON WELDING	TRUCK LIGHT INSTALL	001-5-210-6504	\$	336.00	
BOUND TREE	EMS SUPPLY	001-5-150-6370	\$	85.74	
ENGLISH RIVER WATERSHED	2017 MEMBERSHIP	001-5-520-6425	\$	7,500.00	
FEGUSON WATERWORKS	METER INSTALLATIONS	301-5-750-6791	\$	48.72	
FISHER INSURANCE	RECEPTORS COVERAGE	600-5-810-6504	\$	68.00	
IOWA 1 CALL	LOCATES	600-5-810-6507	\$	21.20	
IOWA 1 CALL	LOCATES	610-5-815-6507	\$	21.20	
JETCO, INC.	LIFT STATION PUMP REPAIRS	610-5-815-6374	\$	808.20	
KALONA AUTO	SHOP	001-5-210-6331	\$	145.44	
KALONA OIL	DIESEL FUEL	110-5-210-6331	\$	410.00	
LENZ, BRYAN	BALANCE DUE ON SHOES	001-5-210-6181	\$	25.00	
MENARDS	SHOP	001-5-210-6372	\$	109.63	
MMS	GENERAL ENGINEERING	600-5-810-6407	\$	30.25	
MMS	HWY 22 WATERMAIN/STREETScape	301-5-750-6781	\$	2,393.00	
MMS	2ND STREET AND WASHBURN	301-5-750-6781	\$	18,121.09	\$ 20,544.34
MMS	POSTAGE - WATER	600-5-810-6508	\$	158.22	
PITNEY BOWES	POSTAGE - SEWER	610-5-815-6508	\$	158.22	\$ 316.44
PITNEY BOWES	HOTEL/MOTEL GRANT	145-5-650-6415	\$	23,880.00	
RACC	SIGN	001-5-430-6371	\$	110.42	
REC	SEWER EXPENSE	610-5-815-6371	\$	3,929.10	
REC	SHOP	001-5-210-6371	\$	42.90	
REC	WATER PLANT	600-5-810-6371	\$	2,433.10	
REC	CASINO LIFT	610-5-815-6371	\$	330.30	
REC	TRAFIC LIGHT	001-5-230-6371	\$	132.14	\$ 6,977.96
REC	HOTEL/MOTEL GRANT	145-5-650-6430	\$	500.00	
RIVERSIDE BALL ASSOC.	RVFD FUEL	001-5-150-6350	\$	243.82	
RIVERSIDE TRAVEL MART	8" CMU WINDOWS	301-5-750-6781	\$	1,000.00	
RUESS MASONRY	HELMET LIGHT/FOAM/D SCREW	001-5-150-6356	\$	1,089.00	
SANDRY FIRE SUPPLY	VICON MOWER REPAIRS	001-5-430-6504	\$	107.08	
SCHNOEBELEN INC.	CITY HALL	001-5-650-6310	\$	40.00	
STANDARD PEST	FIRE STATION	001-5-150-6310	\$	20.00	\$ 60.00
STANDARD PEST	COPIER RENTAL	001-5-650-6496	\$	166.37	
US BANK	USTREAM	001-5-650-6497	\$	99.00	
VISA	CONFERENCE	001-5-650-6240	\$	252.34	
VISA	POSTAGE	001-5-650-6508	\$	313.60	
VISA	2017 TRUCK LIGHTS	001-5-210-6504	\$	479.70	\$ 1,144.64
VISA	SUMMER CAMPS	001-5-430-6502	\$	520.00	
WASHINGTON CO. EXT.	SEWER EXPENSE	610-5-815-6373	\$	237.52	
WINDSTREAM	WATER	600-5-810-6373	\$	218.39	
WINDSTREAM	SHOP	001-5-210-6373	\$	128.56	\$ 584.47
WINDSTREAM	TOTAL UNPAID BILLS		\$	66,713.25	
	PAID BILLS				
IOWA DEPT OF REVENUE	IOWA WITHHOLDINGS - 2017 JULY		\$	520.00	
IOWA DEPT OF REVENUE	IOWA SALES TAX - 2017 JULY		\$	3,284.38	
IPERS	CONTRIBUTIONS - 2017 JULY		\$	1,828.52	
IRS	941 TAX DEPOSIT - 2017 JULY		\$	2,990.25	
PAYROLL	PAYCHECKS - 2017 JULY		\$	9,770.43	
	TOTAL PAID BILLS		\$	18,393.58	
	TOTAL EXPENDITURES		\$	107,138.67	
JULY 2017 REVENUES & EXPENSES:		REVENUES		EXPENSES	
GENERAL FUND		\$ 9,618.14		\$ 59,156.12	
ROAD USE TAX FUND		\$ 12,865.09		\$ -	
LOCAL OPTION SALES TAX		\$ 8,508.46		\$ -	
CASINO REVENUE RUND		\$ 100,537.70		\$ 4,149.39	
CAPITAL PROJECTS FUND		\$ -		\$ 274,110.87	
WATER FUND		\$ 44,126.57		\$ 20,294.46	
SEWER FUND		\$ 40,112.27		\$ 17,388.19	
GARBAGE/LANDFILL FUND		\$ 1,992.84		\$ 1,682.00	
STORM WATER FUND		\$ 1,534.81		\$ -	
TOTAL		\$ 219,295.88		\$ 376,781.03	

CITY OF RIVERSIDE
MTD TREASURERS REPORT
AS OF: JULY 31ST, 2017

Council Packet

BEGINNING CASH BALANCE	M-T-D REVENUES	M-T-D EXPENSES	CASH BASIS BALANCE	NET CHANGE OTHER ASSETS	NET CHANGE LIABILITIES	ACCUAL ENDING CASH BALANCE
2,210,690.05	9,618.14	59,156.12	2,161,152.07	0.00	(589.33)	2,160,562.74
367,793.31	12,865.09	0.00	380,648.40	0.00	0.00	380,648.40
242,268.07	8,508.46	0.00	250,776.53	0.00	0.00	250,776.53
0.00	0.00	0.00	0.00	0.00	0.00	0.00
1,009,764.38	100,537.70	4,149.39	1,106,152.69	0.00	0.00	1,106,152.69
0.00	0.00	0.00	0.00	0.00	0.00	0.00
(167,464.32)	0.00	274,110.87	(441,575.19)	0.00	0.00	(441,575.19)
675,171.56	44,126.57	20,294.46	699,003.67	0.00	(62.97)	698,940.70
218,099.05	40,112.27	17,388.19	240,823.13	0.00	(62.97)	240,760.16
7,696.71	1,992.84	1,682.00	8,007.55	0.00	0.00	8,007.55
17,004.53	1,534.81	0.00	18,539.34	0.00	0.00	18,539.34
4,581,013.34	219,285.88	376,781.03	4,423,528.19	0.00	(715.27)	4,422,812.92

*** END OF REPORT ***

Council Packet

8/17/2017

8-17-2017 01:12 PM

CITY OF RIVERSIDE
 POOLED CASH REPORT (FUND 999)
 AS OF: JULY 31ST, 2017

PAGE: 1

FUND ACCOUNT#	ACCOUNT NAME	BEGINNING BALANCE	CURRENT ACTIVITY	CURRENT BALANCE
<u>CLAIM ON CASH</u>				
001-1110	CHECKING ACCT-GENERAL FUND	2,210,690.05 (50,127.31)	2,160,562.74
110-1110	CHECKING ACCT-ROAD USE TAX	367,783.31	12,865.09	380,648.40
121-1110	CHECKING ACCT-LOST	242,268.07	8,508.46	250,776.53
125-1110	CHECKING ACCT-TIF	0.00	0.00	0.00
145-1110	CHECKING ACCT-CASINO REVENUE	1,009,764.38	96,388.31	1,106,152.69
200-1110	CHECKING ACCT-DEBT SERVICE	0.00	0.00	0.00
301-1110	CHECKING ACCT-CAP PROJECTS	(167,464.32) (274,110.87) (441,575.19)
600-1110	CHECKING ACCT-WATER	675,171.56	23,769.14	698,940.70
610-1110	CHECKING ACCT-SEWER	218,099.05	22,661.11	240,760.16
670-1110	CHECKING ACCT-GARBAGE	7,696.71	310.84	8,007.55
680-1110	CHECKING ACCT-STORM WATER	<u>17,004.53</u>	<u>1,534.81</u>	<u>18,539.34</u>
TOTAL CLAIM ON CASH		<u>4,581,013.34 (</u>	<u>158,200.42)</u>	<u>4,422,812.92</u>

CASH IN BANK - POOLED CASH

999-1110	CASH IN BANK	1,276,773.30 (172,963.15)	1,103,810.15
999-1112	PEOPLES BANK MONEY MARKET	2,089,338.62	1,508.33	2,090,846.95
999-1114	HILLS BANK	655,174.56	11,555.16	666,729.72
999-1115	CB FUND	15,308.19	11.05	15,319.24
999-1116	COMMUNITY BUILDING CD #18936	276,380.39	1,688.19	278,068.58
999-1117	COMMUNITY BUILDING CD#18975	<u>268,038.28</u>	<u>0.00</u>	<u>268,038.28</u>
SUBTOTAL CASH IN BANK - POOLED CASH		<u>4,581,013.34 (</u>	<u>158,200.42)</u>	<u>4,422,812.92</u>

WAGES PAYABLE

999-2010	WAGES PAYABLE	<u>0.00</u>	<u>0.00</u>	<u>0.00</u>
SUBTOTAL WAGES PAYABLE		<u>0.00</u>	<u>0.00</u>	<u>0.00</u>

TOTAL CASH IN BANK - POOLED CASH		<u>4,581,013.34 (</u>	<u>158,200.42)</u>	<u>4,422,812.92</u>
----------------------------------	--	-----------------------	--------------------	---------------------

DUE TO OTHER FUNDS - POOLED CASH

999-2100	DUE TO OTHER FUNDS	<u>4,581,013.34 (</u>	<u>158,200.42)</u>	<u>4,422,812.92</u>
TOTAL DUE TO OTHER FUNDS		<u>4,581,013.34 (</u>	<u>158,200.42)</u>	<u>4,422,812.92</u>

Council Packet

8/17/2017

8-17-2017 01:12 PM

CITY OF RIVERSIDE
 POOLED CASH REPORT (FUND 999)
 AS OF: JULY 31ST, 2017

PAGE: 2

FUND ACCOUNT# ACCOUNT NAME	BEGINNING BALANCE	CURRENT ACTIVITY	CURRENT BALANCE
<u>DUE TO POOLED CASH</u>			
001-2020 ACCOUNTS PAYABLE	0.00	0.00	0.00
110-2020 ACCOUNTS PAYABLE	0.00	0.00	0.00
121-2020 ACCOUNTS PAYABLE	0.00	0.00	0.00
125-2020 ACCOUNTS PAYABLE	0.00	0.00	0.00
145-2020 ACCOUNTS PAYABLE	0.00	0.00	0.00
200-2020 ACCOUNTS PAYABLE	0.00	0.00	0.00
301-2020 ACCOUNTS PAYABLE	0.00	0.00	0.00
600-2020 ACCOUNTS PAYABLE	0.00	0.00	0.00
610-2020 ACCOUNTS PAYABLE	0.00	0.00	0.00
670-2020 ACCOUNTS PAYABLE	0.00	0.00	0.00
680-2020 ACCOUNTS PAYABLE	<u>0.00</u>	<u>0.00</u>	<u>0.00</u>
TOTAL DUE TO POOLED CASH	<u>0.00</u>	<u>0.00</u>	<u>0.00</u>

<u>DUE FROM OTHER FUNDS</u>			
999-1330 DUE FROM OTHER FUNDS	<u>0.00</u>	<u>0.00</u>	<u>0.00</u>
TOTAL DUE FROM OTHER FUNDS	<u>0.00</u>	<u>0.00</u>	<u>0.00</u>

<u>ACCOUNTS PAYABLE - POOLED CASH</u>			
999-2020 ACCOUNTS PAYABLE CONTROL	<u>0.00</u>	<u>0.00</u>	<u>0.00</u>
TOTAL ACCOUNTS PAYABLE POOLED CASH	<u>0.00</u>	<u>0.00</u>	<u>0.00</u>

*** PROOF CASH BALANCES ***

(A)		(B)		(C)	
CLAIM ON CASH	4,422,812.92	CLAIM ON CASH	4,422,812.92	CASH IN BANK	4,422,812.92
CASH IN BANK	<u>4,422,812.92</u>	DUE TO OTHER FUNDS	<u>4,422,812.92</u>	DUE TO OTHER FUNDS	<u>4,422,812.92</u>
DIFFERENCE	0.00		0.00		0.00

*** PROOF ACCOUNTS PAYABLE BALANCES ***

(D)		(E)		(F)	
AP PENDING	0.00	AP PENDING	0.00	DUE FROM OTHER FUNDS	0.00
DUE FROM OTHER FUNDS	<u>0.00</u>	ACCOUNTS PAYABLE	<u>0.00</u>	ACCOUNTS PAYABLE	<u>0.00</u>
DIFFERENCE	0.00		0.00		0.00

*** END OF REPORT ***

Becky LaRoche

From: Licensing@IowaABD.com
Sent: Thursday, August 03, 2017 2:34 AM
To: becky@cityofriversideiowa.com
Cc: Licensing@IowaABD.com
Subject: [POSSIBLE SPAM] Liquor License Submitted to Local Authority

The following licenses are completed and awaiting local authority approval:

License #	License Status	Business Name
BC0026006	Submitted to Local Authority	Riverside Travel Mart (3070 Hwy 22 East Riverside Iowa, 52327-0000)

Please do not respond to this email. Contact the Division's Licensing Section with questions regarding the application process or application status toll-free at 866.iowaABD (866.469.2223) (select option 1), locally 515.281.7400 (select option 1).

For assistance by email contact Licensing@IowaABD.com



Virus-free. www.avg.com

Lory Young

From: Linda Showalter <Linda.Showalter@sui.org>
Sent: Wednesday, August 16, 2017 1:02 PM
To: 'lory@cityofriversideiowa.com'
Cc: 'stardustradionetwork@gmail.com'
Subject: [POSSIBLE SPAM] FW: [External Email] Flood pics July 11th
Attachments: 0712171843a.jpg; 0712171843.jpg; 0711171746a.jpg; 0711171746.jpg; 0711171418.jpg; 0711171417.jpg; 0628170658.jpg; 0711171654.jpg

Hello Lory,

Here are the pictures of the mud problem, which occurred on July 11, 2017. The first picture is the outside of the garage after we cleaned it up. The one that looks blurry is a picture of the drain during the heavy rain. There are some pictures of the drain filled with mud. There are some pictures of what the construction company did to the drain after we complained. There are some pictures of the inside of our garage filled with mud, and a picture of the mud splattered up the entry door to the garage.

We are respectfully requesting to be reimbursed for 25 hours of labor, at \$10 per hour. This was for removal of mud from our sidewalk and garage. We feel that this amount is reasonable, because we both had to take a day and a half off of work, and we both are paid more than \$10 an hour.

Linda Showalter
Staff Supervisor
(319) 338-9212 ext. 620

This message is intended for the use of the individual or entity to which it is addressed and may contain information that is confidential and privileged and exempt from disclosure under applicable law. If the reader of this message is not the intended recipient, you are hereby notified that any dissemination, distribution, or copying of this communication is strictly prohibited. If you have received this communication in error, please contact the sender immediately and delete it from your system. Thank you.



Virus-free. www.avg.com















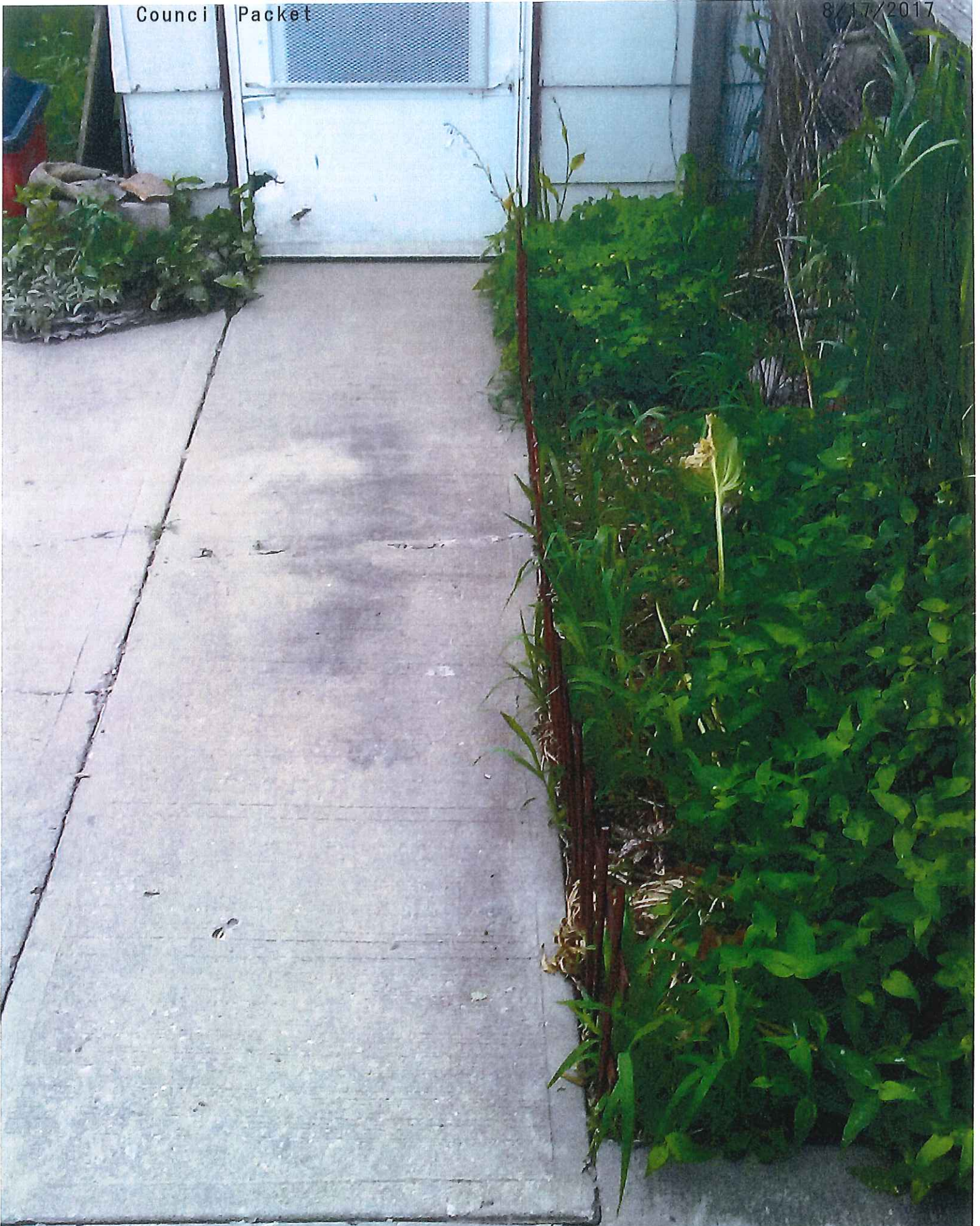

August 13, 2017

To Riverside City Council,

Two and a half weeks ago, we received a letter stating that we owed the City of Riverside an amount just over \$1,800 for services rendered by Kalonial Care & Tree Service. It was stated in this letter that the services were rendered the week immediately prior to Trek Fest. It was also stated that this balance was owed in full, payment arrangements made, or to refute the amount owed by August 15, 2017.

It is our intention with this letter to notify the council that we disagree with the cost owed and will not be paying the \$1,800 in-full for the following reasons:

- As stated in the Riverside city code, a homeowner is to be notified in advance of any work done based on public nuisance and provided a notice to remedy. The city code directly states "*the City may serve notice on the abutting property owner requiring that such action be taken within five (5) days*" 151.03 We were not provided any such notification at any point during our residence in Riverside since August of 2013.
- This issue was placed on to the agenda for a city council meeting. The agenda was released less than 7 days prior to the work itself being performed. Not being given any notification or the appropriate amount of consideration, we feel the decision to blindly (and seemingly flippantly) contract work to be paid for by a (low-income) single-family residence of the city is inexcusable. We were not notified of any actions regarding our property being a topic of discussion at the Council meeting.
- Given proper notice of the apparent public nuisance, we would have informed the city that we had already made plans for outside services (not Kalonial Care & Tree Service) to attend to our lawn. The agreed upon expense for our lawn care was not to exceed \$150 and was to take place 48 hours after we found our yard had been done at City request.
- The amount of work done by the company asked to attend to our yard far exceeded that of what it was asked to do. The lawn care company was asked to attend to the outer property grass and to trim the outer hedges. What we have been asked to pay was for services done including tree trimming and tree removal within the inner portion of our yard, against the house. This is especially concerning as it entailed the removal of a magnolia tree that we had been helping to grow and appreciated. It was a young tree (18 months old approximately) and was in no way, shape, or form a nuisance to any neighbor. This tree was not close to the sidewalk and was not on public property. We also found that the other trees in our yards had been severely deboughed and the hedges cut to less than 18 inches tall which allows for no notion of the privacy they once provided. We agree that the hedges were tall. However, again, if we had been notified of this "nuisance" we would have informed the City that there were plans in place for the hedges to be trimmed along with grass mowed (all for \$150).

• In addition to the excessive work done to our yard, we were disheartened to find that one of the kids' bikes and a kids scooter that was on the brick patio on the rear of our home were either missing or destroyed. These items belonged to our 3 year old and 7 year old daughters respectively. The girls had used them the evening before the work was done and were distraught to find that their items were no longer in the yard or useable when we arrived home the day the work was completed. We do not intend to accuse the lawn care company of theft or deliberate destruction of our children's toys, but if not removed by persons' contracted by the city- the lack of care taken to prevent damage to personal property and severe removal of privacy to our yard is unacceptable. In an effort to access the inner most portions of our yards (not asked for by the city as it was located between our home and retaining wall) a swing set was moved by Kalonial Care & Tree Service. This play set was moved to a different location on our property and the bar attaching the slide to the main structure of this item was bent. While we have bent it back into place, the structural damage to the girls' swingset is irreparable. The longevity of this personal property is compromised.

***Please note that (at this time) we are not seeking any compensation for the damages and loss sustained at our home when the lawn services were performed. We are asking that they be taken into consideration as you review our appeal to the charges assessed.

• It is our understanding that Kalonial Care & Tree Services were contracted for our yard instead of using the city workers because the city workers were otherwise engaged in preparation for the impending Trek Fest. If it had not been for Trek Fest approaching the following weekend, the timing of which is outside of our control, Kalonial Tree & Lawn Services would not have been used. It is highly presumable that the Kalonial Tree & Lawn Services assess a higher profit margin onto their services than that of the city itself.

It is for the aforementioned reasons that we vehemently appeal the charges assessed to our family for lawn care services on our personal property. We will happily provide to the City of Riverside the amount previously agreed upon with an outside provider in the amount of \$150.00 (cash or check for which will be made available to City Hall by October 1, 2017 unless otherwise arranged.

Sincerely,

Brad and Kristin Fuhrmann

Sent out
in June 2015
& June 2016

OFFICIAL NOTICE

The City of Riverside has noticed that the grass from your property has been blown out into the street. This is against City Code Section 135.03 as shown below:

135.03 PLACING DEBRIS ON. *It is unlawful for any person to throw or deposit on any street or alley any glass, glass bottle, nails, tacks, wire, cans, trash, garbage, rubbish, litter, offal, leaves, grass or any other debris likely to be washed into the storm sewer and clog the storm sewer, or any substance likely to injure any person, animal or vehicle.*

(Code of Iowa, Sec. 321.369)

City of Riverside enforcement actions will include a municipal citation, which carries a fine of \$25.00 for the first offense, \$50.00 for second offense and \$100.00 for each subsequent offense. Each day is considered a separate offense.

OFFICIAL NOTICE

You are receiving this notice of fine for \$25 for throwing grass into the street this past weekend. Fine is due by 06/06/16.

The City of Riverside has noticed that the grass from your property has been blown out into the street. This is against City Code Section 135.03 as shown below:

135.03 PLACING DEBRIS ON. *It is unlawful for any person to throw or deposit on any street or alley any glass, glass bottle, nails, tacks, wire, cans, trash, garbage, rubbish, litter, offal, leaves, grass or any other debris likely to be washed into the storm sewer and clog the storm sewer, or any substance likely to injure any person, animal or vehicle.*

(Code of Iowa, Sec. 321.369)

City of Riverside enforcement actions will include a municipal citation, which carries a fine of \$25.00 for the first offense, \$50.00 for second offense and \$100.00 for each subsequent offense. Each day is considered a separate offense.

June 5, 2017

Brad Fuhrmann
181 East 4th Street
PO Box 406
Riverside, IA 52327

Dear Brad,

This letter is in regards to your property located at 181 E 4th Street here in Riverside. It has been brought to our attention that you have dense vegetation growing on the southwest corner and along the south side of your property that may be impairing the vision at the intersection of St. Mary's Street and N Ella Street and E 4th Street and N Ella Street.

This dense vegetation is in violation of City Ordinance 50.02(5 & 9):

5. "Blocking public or private ways, obstructing or encumbering, by fences, buildings or otherwise, the public roads, private ways, streets, alleys, commons, landing places..."

9. "Weeds, Brush, dense growth of all weeds, vines, brush, or other vegetation in the City so as to constitute a health, safety, or fire hazard."

The City of Riverside would like you to please remove or trim the dense vegetation down so it will no longer obstruct vision at this intersection and clean up the vegetation on your property by June 30th, 2017. If you have any questions, please call City Hall.

Your prompt attention to this matter is appreciated.

Sincerely,

Lory Young
City Clerk



June 8, 2017

Dear Riverside Citizen:

This letter is in regards to the monthly "Stick Pick-up". The City Council Members voted to pick up sticks on Wednesday, June 14th, 2017. This will be the last stick pick up until October 2017.

The City of Riverside will be enforcing our City Ordinances regarding keeping lawns and ditched mowed, clippings, grass, and other debris being deposited or thrown into the City street or alleyways.

Chapter 50.02 (5 & 9) of the City of Riverside's City Code states it is unlawful to:

- 5. "Blocking public or private ways, obstructing or encumbering, by fences, buildings, or otherwise, the public roads, private ways, streets, alleys, commons, landing places..."
- 9. "Weeds, Brush, dense growth of all weeds, vines, bushes, or other vegetation in the City as to constitute a health, safety, or fire hazard."

Chapter 135.03 of the City of Riverside's City Code states:

It is unlawful for any person to throw or deposit on any city street or alleyway and glass, glass bottles, nails, tacks, wire, cans, trash, garbage, rubbish, litter, leaves, grass or any kind of debris likely to be washing into the storm sewer and clog the storm sewer.....

The City of Riverside is reminding you to make sure you're aware of our City Ordinances. This is a "courtesy notification". If violations are reported or seen, you may be subject to a city fine.

Your cooperation in this matter is greatly appreciated.

Sincerely,

A handwritten signature in cursive script that reads "Lory Young".

Lory Young
City Clerk

Notification sent by the direction of the Riverside City Council!

July 21, 2017

Brad Fuhrmann
181 East 4th Street
PO Box 406
Riverside, IA 52327

Dear Brad,

This letter is in regards to your property located at 181 E 4th Street here in Riverside.

Enclosed is a copy of the bill for having your property cleaned up in the amount of \$1,865.00. The City has paid Kalonial Lawn Care for their services and we will give you until August 15th, 2017 to make payment to the City. If you cannot pay this fee, in full, by August 15th, 2017, we are willing to set up a payment arrangement.

The payment arrangement we are willing to offer you would be 12 equal payments of \$155.42 due by the 15th of each month, until balance is paid in full, with the first payment of \$155.42 being due August 15th, 2017.

If neither one of these options will work for you, the City will be forced to certify the expense through the County Treasurer and have the balance of \$1,865.00 plus and administration fee of \$50.00, for a total of \$1,915.00, assessed to your property taxes for payment.

If you have any questions, please call or stop in City Hall. Your prompt attention to this matter is appreciated.

Sincerely,

Lory Young
City Clerk

Signed: _____
Brad Fuhrmann

Date: _____



MMS Consultants, Inc.
Experts in Planning and Development Since 1975

1917 S. Gilbert Street
Iowa City, Iowa 52240

319.351.8282

mmsconsultants.net
mms@mmsconsultants.net

Environmental Specialists

Landscape Architects

Land Planners

Land Surveyors

Civil Engineers

August 17, 2017

Mr. Allen Schneider, Mayor
City of Riverside
PO Box 188
Riverside, IA 52327

RE: Americans with Disabilities Act, Riverside, Iowa

Honorable Mayor Schneider:

We respectfully would like to address some comments that have been made regarding the construction of the "Accessible Routes" on the Washburn/2nd Street Project in Riverside, Iowa.

Please refer to Chapter 4: Accessible Routes in the Guide entitled Americans with Disabilities Act and Architectural Barriers Act Accessibility Guidelines dated July 23, 2004.

Chapter 402.2 Components and 403.3 Slope Walking Surfaces must have running slopes not steeper than 1:20. The cross slope of walking surfaces shall not be steeper than 1:48.

Chapter 403.5.1 The clear width of walking surfaces shall be 36" minimum. (See Figure 403.5.1)

Chapter 403.5.2 clear width at turn (see Figure 403.5.2)

We are greater than 60", therefore 36" walking surface is required. We have over 42" in all instances.

Chapter 404.2 Manual Doors, Doorways and Manual Gates. Refer to the Table 404.2.4.1 and Figures 404.2.4.1

We are including pages 154-161 that includes language, figures and tables that addresses the requirements for this project.

Next we would like to address each of the four doors that enter onto the Washburn/2nd Street Project facing onto Highway #22.

The most westerly doorway of this project is to the property owned by Bob Ryan addressed as 21 1st Street W has the following conditions:

1. Door is a "pull" situation.
2. The inside of the building has steps up to the 2nd floor.
3. The clear width of the accessible route is 42".
4. There is a metal plate on the east side of the doorway that extends 2" into the accessible route. If there is a concern, this plate could be moved back into its original position.
5. This doorway does not qualify as an accessible route.



MMS Consultants, Inc.
Experts in Planning and Development Since 1975

1917 S. Gilbert Street
Iowa City, Iowa 52240
319.351.8282

mmsconsultants.net
mms@mmsconsultants.net

Environmental Specialists

Landscape Architects

Land Planners

Land Surveyors

Civil Engineers

The next (second) doorway to the east is to the property owned by Randy Klein addressed as 11 1st Street W has the following conditions:

1. Door is a "pull" situation.
2. There is a step from the new sidewalk to the doorway.
3. The clear width of the accessible route is 44".
4. This doorway does not qualify as an accessible route.

The third doorway is on the east side of Washburn to the property owned by Bob Ryan addressed as 11 1st Street E has the following conditions:

1. Door is a "push" situation.
2. The doorway is accessible but not being used.
3. The clear width of the accessible route is 46".
4. This doorway meets all conditions of accessibility.
Refer to "f" and "j" approach for this door.

The fourth doorway to the property owned by Kevin Kiene addressed as 21 1st Street E has the following conditions:

1. The main door is a "push" situation.
2. The screen door is in a "pull" situation. It has a closer and latch.
3. The inside floor is level with new sidewalk.
4. The clear width is 47 1/4".
5. The main door meets the requirement of maneuvering clearance.
6. The screen door may not meet the requirement of maneuvering clearance.

Refer to "f" and "j" approach on pages 158 and 159 for main door.
Refer to "e" and "i" approach on pages 158 and 159 for screen door.

This letter will allow for discussion concerning the required widths in various applications.

Respectfully submitted,

Glen D. Meisner, PE & PLS

T:\2245\2245-032-\2245032L2.docx

CHAPTER 4: ACCESSIBLE ROUTES

401 General

401.1 Scope. The provisions of Chapter 4 shall apply where required by Chapter 2 or where referenced by a requirement in this document.

402 Accessible Routes

402.1 General. Accessible routes shall comply with 402.

402.2 Components. Accessible routes shall consist of one or more of the following components: walking surfaces with a running slope not steeper than 1:20, doorways, ramps, curb ramps excluding the flared sides, elevators, and platform lifts. All components of an accessible route shall comply with the applicable requirements of Chapter 4.

Advisory 402.2 Components. Walking surfaces must have running slopes not steeper than 1:20, see 403.3. Other components of accessible routes, such as ramps (405) and curb ramps (406), are permitted to be more steeply sloped.

403 Walking Surfaces

403.1 General. Walking surfaces that are a part of an accessible route shall comply with 403.

403.2 Floor or Ground Surface. Floor or ground surfaces shall comply with 302.

403.3 Slope. The running slope of walking surfaces shall not be steeper than 1:20. The cross slope of walking surfaces shall not be steeper than 1:48.

403.4 Changes in Level. Changes in level shall comply with 303.

403.5 Clearances. Walking surfaces shall provide clearances complying with 403.5.

EXCEPTION: Within employee work areas, clearances on common use circulation paths shall be permitted to be decreased by work area equipment provided that the decrease is essential to the function of the work being performed.

403.5.1 Clear Width. Except as provided in 403.5.2 and 403.5.3, the clear width of walking surfaces shall be 36 inches (915 mm) minimum.

EXCEPTION: The clear width shall be permitted to be reduced to 32 inches (815 mm) minimum for a length of 24 inches (610 mm) maximum provided that reduced width segments are separated by segments that are 48 inches (1220 mm) long minimum and 36 inches (915 mm) wide minimum.

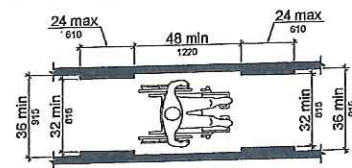

Figure 403.5.1
Clear Width of an Accessible Route

403.5.2 Clear Width at Turn. Where the accessible route makes a 180 degree turn around an element which is less than 48 inches (1220 mm) wide, clear width shall be 42 inches (1065 mm) minimum approaching the turn, 48 inches (1220 mm) minimum at the turn and 42 inches (1065 mm) minimum leaving the turn.

EXCEPTION: Where the clear width at the turn is 60 inches (1525 mm) minimum compliance with 403.5.2 shall not be required.

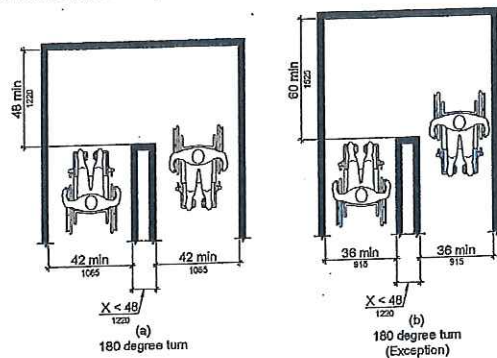

Figure 403.5.2
Clear Width at Turn

CHAPTER 4: ACCESSIBLE ROUTES

TECHNICAL

403.5.3 Passing Spaces. An accessible route with a clear width less than 60 inches (1525 mm) shall provide passing spaces at intervals of 200 feet (61 m) maximum. Passing spaces shall be either: a space 60 inches (1525 mm) minimum by 60 inches (1525 mm) minimum; or, an intersection of two walking surfaces providing a T-shaped space complying with 304.3.2 where the base and arms of the T-shaped space extend 48 inches (1220 mm) minimum beyond the intersection.

403.6 Handrails. Where handrails are provided along walking surfaces with running slopes not steeper than 1:20 they shall comply with 505.

Advisory 403.6 Handrails. Handrails provided in elevator cabs and platform lifts are not required to comply with the requirements for handrails on walking surfaces.

404 Doors, Doorways, and Gates

404.1 General. Doors, doorways, and gates that are part of an accessible route shall comply with 404. **EXCEPTION:** Doors, doorways, and gates designed to be operated only by security personnel shall not be required to comply with 404.2.7, 404.2.8, 404.2.9, 404.3.2 and 404.3.4 through 404.3.7.

Advisory 404.1 General Exception. Security personnel must have sole control of doors that are eligible for the Exception at 404.1. It would not be acceptable for security personnel to operate the doors for people with disabilities while allowing others to have independent access.

404.2 Manual Doors, Doorways, and Manual Gates. Manual doors and doorways and manual gates intended for user passage shall comply with 404.2.

404.2.1 Revolving Doors, Gates, and Turnstiles. Revolving doors, revolving gates, and turnstiles shall not be part of an accessible route.

404.2.2 Double-Leaf Doors and Gates. At least one of the active leaves of doorways with two leaves shall comply with 404.2.3 and 404.2.4.

404.2.3 Clear Width. Door openings shall provide a clear width of 32 inches (815 mm) minimum. Clear openings of doorways with swinging doors shall be measured between the face of the door and the stop, with the door open 90 degrees. Openings more than 24 inches (610 mm) deep shall provide a clear opening of 36 inches (915 mm) minimum. There shall be no projections into the required clear opening width lower than 34 inches (865 mm) above the finish floor or ground. Projections into the clear opening width between 34 inches (865 mm) and 80 inches (2030 mm) above the finish floor or ground shall not exceed 4 inches (100 mm).

EXCEPTIONS: 1. In alterations, a projection of 5/8 inch (16 mm) maximum into the required clear width shall be permitted for the latch side stop.
2. Door closers and door stops shall be permitted to be 78 inches (1980 mm) minimum above the finish floor or ground.

CHAPTER 4: ACCESSIBLE ROUTES

TECHNICAL

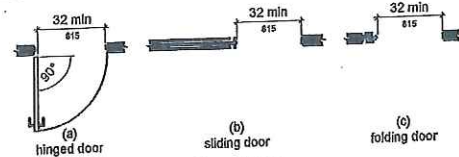

Figure 404.2.3
Clear Width of Doorways

404.2.4 Maneuvering Clearances. Minimum maneuvering clearances at doors and gates shall comply with 404.2.4. Maneuvering clearances shall extend the full width of the doorway and the required latch side or hinge side clearance. **EXCEPTION:** Entry doors to hospital patient rooms shall not be required to provide the clearance beyond the latch side of the door.

404.2.4.1 Swinging Doors and Gates. Swinging doors and gates shall have maneuvering clearances complying with Table 404.2.4.1.

Table 404.2.4.1 Maneuvering Clearances at Manual Swinging Doors and Gates

Type of Use		Minimum Maneuvering Clearance	
Approach Direction	Door or Gate Side	Perpendicular to Doorway	Parallel to Doorway (beyond latch side unless noted)
From front	Pull	60 inches (1525 mm)	18 inches (455 mm)
From front	Push	48 inches (1220 mm)	0 inches (0 mm) ¹
From hinge side	Pull	60 inches (1525 mm)	36 inches (915 mm)
From hinge side	Push	54 inches (1370 mm)	42 inches (1065 mm)
From latch side	Pull	42 inches (1065 mm) ²	22 inches (560 mm) ³
From latch side	Push	48 inches (1220 mm) ⁴	24 inches (610 mm)

1. Add 12 inches (305 mm) if closer and latch are provided.
2. Add 6 inches (150 mm) if closer and latch are provided.
3. Beyond hinge side.
4. Add 6 inches (150 mm) if closer is provided.

CHAPTER 4: ACCESSIBLE ROUTES

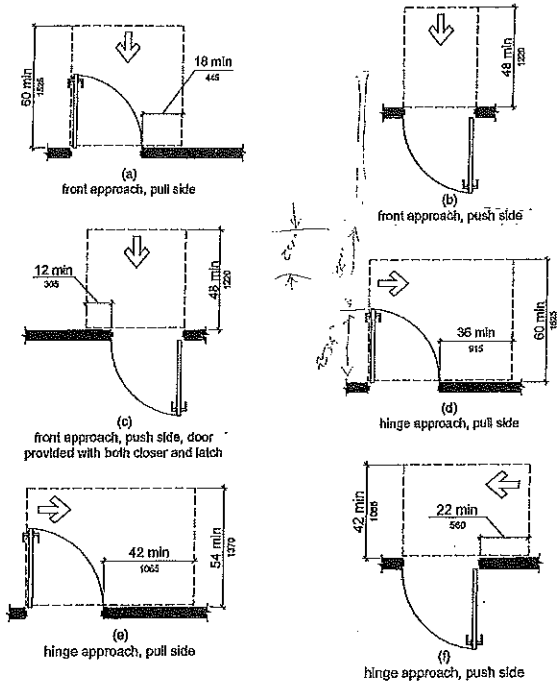

Figure 404.2.4.1
Maneuvering Clearances at Manual Swinging Doors and Gates

TECHNICAL

CHAPTER 4: ACCESSIBLE ROUTES

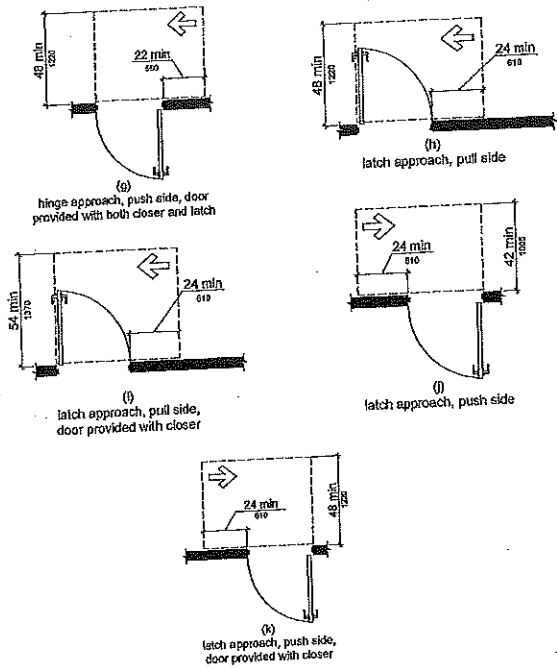

Figure 404.2.4.1
Maneuvering Clearances at Manual Swinging Doors and Gates

CHAPTER 4: ACCESSIBLE ROUTES

TECHNICAL

404.2.4.2 Doorways without Doors or Gates, Sliding Doors, and Folding Doors. Doorways less than 36 inches (915 mm) wide without doors or gates, sliding doors, or folding doors shall have maneuvering clearances complying with Table 404.2.4.2.

Table 404.2.4.2 Maneuvering Clearances at Doorways without Doors or Gates, Manual Sliding Doors, and Manual Folding Doors

Approach Direction	Minimum Maneuvering Clearance	
	Perpendicular to Doorway	Parallel to Doorway (beyond stop/latch side unless noted)
From Front	48 inches (1220 mm)	0 inches (0 mm)
From side ¹	42 inches (1065 mm)	0 inches (0 mm)
From pocket/hinge side	42 inches (1065 mm)	22 inches (560 mm) ²
From stop/latch side	42 inches (1065 mm)	24 inches (610 mm)

1. Doorway with no door only.
2. Beyond pocket/hinge side.

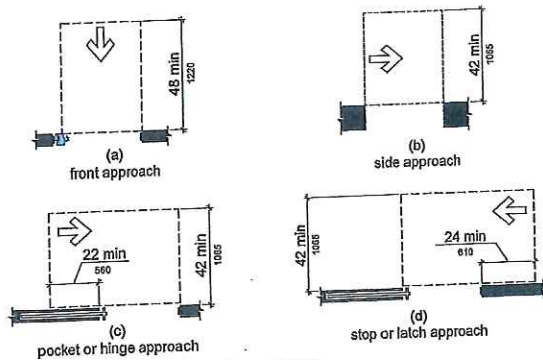

Figure 404.2.4.2

Maneuvering Clearances at Doorways without Doors, Sliding Doors, Gates, and Folding Doors

CHAPTER 4: ACCESSIBLE ROUTES

TECHNICAL

404.2.4.3 Recessed Doors and Gates. Maneuvering clearances for forward approach shall be provided when any obstruction within 18 inches (455 mm) of the latch side of a doorway projects more than 8 inches (205 mm) beyond the face of the door, measured perpendicular to the face of the door or gate.

Advisory 404.2.4.3 Recessed Doors and Gates. A door can be recessed due to wall thickness or because of the placement of casework and other fixed elements adjacent to the doorway. This provision must be applied wherever doors are recessed.

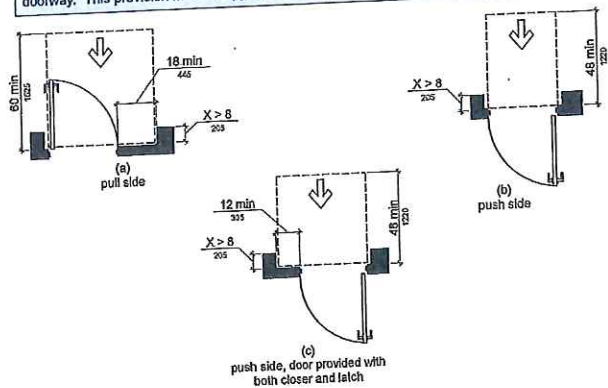

Figure 404.2.4.3

Maneuvering Clearances at Recessed Doors and Gates

404.2.4.4 Floor or Ground Surface. Floor or ground surface within required maneuvering clearances shall comply with 302. Changes in level are not permitted.

- EXCEPTIONS: 1. Slopes not steeper than 1:48 shall be permitted.
2. Changes in level at thresholds complying with 404.2.5 shall be permitted.

404.2.5 Thresholds. Thresholds, if provided at doorways, shall be 1/2 inch (13 mm) high maximum. Raised thresholds and changes in level at doorways shall comply with 302 and 303.
EXCEPTION: Existing or altered thresholds 1/4 inch (19 mm) high maximum that have a beveled edge on each side with a slope not steeper than 1:2 shall not be required to comply with 404.2.5.



MMS Consultants, Inc.
Experts in Planning and Development Since 1975

August 7, 2017

Allen Schneider, Mayor
Riverside City Council Members
Lory Young, City Clerk
City of Riverside
PO Box 188
Riverside, Iowa 52327

RE: Pioneer Project including Alley Vacation West of Murphy's Bar

Honorable Mayor Schneider, Riverside City Council Members and Lory Young:

I am writing this letter at your request concerning the Pioneer Project including the alley west of Murphy's Bar where the alley approaches Highway #22.

During the last year we have had various discussions concerning the south one-half of the north-south alley adjacent to and west of Murphy's Bar and Grill. It has been my recommendation to vacate this portion of the north-south alley for the following reasons:

1. Safety - This alley has been in existence since Riverside has been platted as a town. The visibility for motorists travelling south onto Iowa Highway #22 is impaired. Highway #22 veers northeasterly east of this alley in Riverside. The south bound motorist leaving the alley has a difficult time seeing both to the east and west due to the angle in the road to the east as well as traversing between parked cars on the north side of Iowa Highway #22. The speed limit of Iowa Highway #22 in this area is 25 MPH.
2. Reconstruction of the raised sidewalks between Greene Street and Glasgow Street - The alley slopes from north to south as it enters Highway #22. The steepness of the alley combined with complying with the Americans With Disabilities Act (ADA) makes it more difficult to design and construct this alley, Highway #22 and the elevated sidewalk. The elimination of the alley then allows for the elevated sidewalk to be constructed straight through on the north side of Iowa Highway #22. The elevated sidewalk then would not require two ADA Ramps.
3. Costs - The City of Riverside can save approximately \$81,340.00 by not constructing two ramps, one on each side of the alley. These costs were based on the contract price of the Washburn/2nd Street Project where the cost of a lineal foot of wall was \$1,162.00. We have determined we would eliminate 70 feet of wall. Therefore, 70 feet of wall times \$1,162.00/lineal foot of wall equals = \$81,340.00.

Environmental Specialists

Landscape Architects

Land Planners

Land Surveyors

Civil Engineers



MMS Consultants, Inc.
Experts in Planning and Development Since 1975

1917 S. Gilbert Street
Iowa City, Iowa 52240
319.351.8282
mmsconsultants.net
mms@mmsconsultants.net

Environmental Specialists

Landscape Architects

Land Planners

Land Surveyors

Civil Engineers

During our most recent work session on June 15, 2017 we looked at various alternatives to find better alley access in this particular block in Riverside. Those alternatives are as follows:

1. Establish and construct an east-west alley from Washburn Street to Greene Street.
2. Improve the current alley from Washburn Street to 2nd Street by doing one of the following:
 - A. Purchase the garage from Greg Sojka and cut the corner and remove the power pole.
 - B. Purchase the garage from Laura Temple (or new owner once sold) and round the corner and avoid the power pole by Greg Sojka.
 - C. Move the east-west alley to the south and attempt to align with the alley to the north toward 2nd Street.

We should continue our discussion of this subject so that we can proceed with the most cost effective plan, the safest plan and the best plan that benefits the citizens of Riverside.

Respectfully submitted,

Glen D. Meisner, PE & PLS

T:\2245\2245-013-\2245013L1.docx

RESOLUTION #082117-01

RESOLUTION APPROVING PAY REQUEST #4 FOR DAVE SCHMITT CONSTRUCTION FOR THE 2ND & WASHBURN STREET IMPROVEMENTS CONSTRUCTION PROJECT

Whereas, the City of Riverside City at the recommendation of the City Engineering Firm, MMS Consultants, Scott Pottorff and it is the opinion of the City Engineering Firm that the City Council accept this pay request in the amount of \$262,765.29.

Therefore, be it resolved the City of Riverside City Council does hereby accept the Pay Request #3 for work done on the 2nd & Washburn Streets Improvement Project.

It was moved by Councilperson _____, seconded by Councilperson _____, to approve the foregoing resolution on August 21st, 2017.

Roll Call: Redlinger, Schneider, Sexton, Weber, Schnoebelen

Ayes:

Nays:

Absents:

PASSED AND APPROVED by City Council of Riverside, Iowa, on this 21st day of August, 2017.

Signed: _____

Allen Schneider, Mayor

Attest: _____

Lory Young, City Clerk

CONSTRUCTION PROGRESS PAYMENT

Project Description 2nd Street and Washburn Street Storm Sewer and Paving Project
 Contract Date 10-Apr-17

PN: 2245032

Contractor: Dave Schmitt Construction
 Address: 250 50th Avenue SW
 City, St., Zip: Cedar Rapids, IA 52404
 Phone: 319-365-8669
 Fax: 319-365-2677

Owner: City of Riverside
 Attn: _____
 Address: 60 N. Greene Street
 City, St., Zip: Riverside, IA 52327
 Phone: 319-648-3501
 Fax: _____

Estimate #

<input type="checkbox"/>	4
<input checked="" type="checkbox"/>	x
<input type="checkbox"/>	

Partial Payment
 Final Payment

FOR PERIOD:
 FROM: 7/10/17
 TO: 8/11/17

Owner PN _____
 Federal PN _____
 State PN _____

Base Contract Price \$1,322,934.63

Change #	1	\$16,864.80
Change #	2	\$6,719.25
Change #	3	\$26,679.50
Change #	4	\$11,595.00
Change #	5	\$10,780.00
Change #	6	(\$2,079.50)
Change #	7	\$2,706.00
Change #	8	\$3,236.00
Change #	9	\$4,793.09
Change #	10	\$559.35
Change #	11	\$3,125.00

Total Contract \$1,407,913.12

Materials on Hand \$ -

Construction Completed \$1,111,050.77

Total Earned \$1,111,050.77

Less Retainage \$55,552.54

Less Previous Payment \$792,732.94

Amount Due This Est \$262,765.29

Project Completion 78.91%

Requested by: _____
Shaun Kukuzke
 Title: Project Manager
 Date: _____

Approved by: _____
 Title: _____
 Date: _____

Recommended by: _____
Scott Pottorff
 Title: Project Engineer
 Date: _____

Attested by: _____
 Title: _____
 Date: _____

MMS Consultants, Inc.
 1917 South Gilbert Street, Iowa City, IA 52240

i:\proj\forms\payreqst.xls

2nd Street and Washburn Street Storm Sewer and Paving Project

Pay Estimate No.: 4

Payable to: Dave Schmitt Construction
 Date: August 15, 2017
 Week Ending: August 11, 2017

Item No.	Item Description	Units	Contract Quantity	Unit Price	Contract Amount	Quantity This Estimate	Amount This Estimate	To Date Quantity	To Date Amount
1	Traffic Control	LS	1	\$9,450.00	\$ 9,450.00	-	-	0.75	\$ 7,087.50
2	Mobilization	LS	1	\$106,000.00	\$ 106,000.00	-	-	1.00	\$ 106,000.00
3	Cleaning and Grubbing	LS	1	\$4,140.00	\$ 4,140.00	-	-	1.00	\$ 4,140.00
4	Off Site Topsoil	CY	500	\$40.50	\$ 20,250.00	-	-	-	\$ -
5	Excavation, Class 13	CY	2,000	\$16.00	\$ 32,000.00	-	-	2,000.00	\$ 32,000.00
6	Below Grade Excavation (Corr Out)	CY	300	\$56.00	\$ 16,800.00	28.15	\$ 1,576.40	28.15	\$ 1,576.40
7	Subgrade Preparation	SY	6,172	\$2.75	\$ 16,973.00	-	-	6,172.00	\$ 16,973.00
8	Subbase, Modified, 6" Thick for Mainline PCC Paving	SY	6,172	\$6.75	\$ 41,661.00	360.00	\$ 2,025.00	6,172.00	\$ 41,661.00
9	Subbase, Modified, 4" Thick for PCC Sidewalk and PCC Driveway	SY	1,202	\$15.85	\$ 19,051.70	900.00	\$ 14,285.00	986.00	\$ 15,628.70
10	Subbase, Macadam Stone, 6" Thick	SY	503	\$3.85	\$ 1,954.55	-	-	-	\$ -
11	Subbase, Class A Crushed Stone, 4" Thick	SY	503	\$5.10	\$ 2,565.30	-	-	-	\$ -
12	Removal of Culverts	EA	5	\$1,425.00	\$ 7,125.00	2.00	\$ 2,850.00	6.00	\$ 8,550.00
13	Removal of Box Culvert	LF	150	\$36.25	\$ 5,437.50	-	-	150.00	\$ 5,437.50
14	Backfilling of Curbs	LF	2,220	\$9.05	\$ 20,091.00	1,000.00	\$ 9,050.00	1,175.00	\$ 10,633.75
15	Trench Foundation	TONS	150	\$21.45	\$ 3,217.50	-	-	-	\$ -
16	Replacement of Unsuitable Backfill Material, Granular Backfill	CY	200	\$34.55	\$ 6,910.00	-	-	-	\$ -
17	Trench Compaction Testing	LS	1	\$5,500.00	\$ 5,500.00	-	-	1.00	\$ 5,500.00
18	Granular Trench Backfill, Porous Backfill, 12" Storm Sewer	LF	137	\$13.00	\$ 1,781.00	-	-	137.00	\$ 1,781.00
19	Granular Trench Backfill, Porous Backfill, 18" Storm Sewer	LF	423	\$15.65	\$ 6,619.95	-	-	428.00	\$ 6,698.20
20	Granular Trench Backfill, Porous Backfill, 30" Storm Sewer	LF	175	\$34.65	\$ 6,063.75	-	-	45.00	\$ 1,559.25
21	Granular Trench Backfill, Class A Crushed Stone, 24" Storm Sewer	LF	92	\$16.50	\$ 1,518.00	-	-	92.00	\$ 1,518.00
22	Granular Trench Backfill, Class A Crushed Stone, 8" PVC Water Main	LF	50	\$30.25	\$ 1,512.50	-	-	50.00	\$ 1,512.50
23	Storm Sewer, Trenched, RCP, 12" Dia.	LF	578	\$40.25	\$ 23,304.75	-	-	580.00	\$ 23,345.00
24	Storm Sewer, Trenched, RCP, 18" Dia.	LF	747	\$39.25	\$ 29,319.75	-	-	749.00	\$ 29,398.25
25	Storm Sewer, Trenched, RCP, 24" Dia.	LF	402	\$68.74	\$ 27,633.48	-	-	402.00	\$ 27,633.48
26	Storm Sewer, Trenched, RCP, 30" Dia.	LF	322	\$63.00	\$ 20,316.00	-	-	253.00	\$ 15,939.00
27	Storm Sewer, Trenched, RCP, 36" Dia.	LF	79	\$88.75	\$ 7,011.25	-	-	79.00	\$ 7,011.25
28	Install 15' Band and 15' ADS N-12 to Connect to New Intake	LS	1	\$1,850.00	\$ 1,850.00	-	-	1.00	\$ 1,850.00
29	Removal of Storm Sewer	LF	886	\$18.15	\$ 16,080.90	-	-	886.00	\$ 16,080.90
30	Fill Storm Sewer with Flowable Mortar	LF	125	\$21.60	\$ 2,700.00	-	-	125.00	\$ 2,700.00
31	Flared End Section, RCP, 36"	EA	1	\$1,605.00	\$ 1,605.00	-	-	1.00	\$ 1,605.00
32	Longitudinal Subdrain, Type 2, 6"	LF	1,039	\$13.25	\$ 13,766.75	1,039.00	\$ 13,766.75	1,039.00	\$ 13,766.75
33	Subdrain Cleanout, Type A-1	EA	6	\$436.00	\$ 2,616.00	6.00	\$ 2,616.00	6.00	\$ 2,616.00
34	Subdrain Outlet, Connection to Structure	EA	7	\$192.00	\$ 1,344.00	7.00	\$ 1,344.00	7.00	\$ 1,344.00
35	Connect Existing Sump Pump Outlet to Storm Sewer or Subdrain, Same Side of Street as Pipe	EA	4	\$220.00	\$ 880.00	6.00	\$ 1,320.00	6.00	\$ 1,320.00
36	Connect Existing Sump Pump Outlet to Storm Sewer or Subdrain, Opposite Side of Street	EA	4	\$325.00	\$ 1,300.00	-	-	-	\$ -
37	Water Main, 6", PVC DIP -	LF	303	\$104.10	\$ 31,542.30	-	-	303.00	\$ 31,542.30
38	Water Main, 8", PVC C900	LF	50	\$67.75	\$ 3,387.50	-	-	50.00	\$ 3,387.50
39	Water Main, Trenchless, 6", DIP Restrained Joint *	LF	125	\$127.25	\$ 15,906.25	-	-	125.00	\$ 15,906.25
40	Fire Hydrant Assembly, With Nitrile Gaskets *	EA	1	\$4,047.00	\$ 4,047.00	-	-	1.00	\$ 4,047.00
41	Remove Existing Fire Hydrant Assembly, With Nitrile Gaskets *	EA	1	\$970.00	\$ 970.00	-	-	1.00	\$ 970.00
42	Remove and Reinstall Existing Fire Hydrant Assembly, With Nitrile Gaskets *	EA	1	\$2,422.00	\$ 2,422.00	-	-	1.00	\$ 2,422.00
43	Water Service, Main to Within 2' of Building, 1" Copper (Type K)	EA	3	\$2,525.00	\$ 7,575.00	-	-	3.00	\$ 7,575.00
44	Water Service, Main to Curb Stop, 1" Copper (Type K)	EA	1	\$1,135.00	\$ 1,135.00	-	-	1.00	\$ 1,135.00
45	Gate Valve, 6", With Nitrile Gaskets *	EA	5	\$1,063.00	\$ 5,315.00	-	-	5.00	\$ 5,315.00
46	Gate Valve, 8", With Nitrile Gaskets *	EA	2	\$1,418.00	\$ 2,836.00	-	-	2.00	\$ 2,836.00
47	Valve Box Adjustment, Minor	EA	3	\$345.00	\$ 1,035.00	-	-	-	\$ -
48	Storm Manhole, Type SW-401, 48" Dia	EA	5	\$2,800.00	\$ 14,000.00	-	-	5.00	\$ 14,000.00

Item No.	Item Description	Units	Contract Quantity	Unit Price	Contract Amount	Quantity This Estimate	Amount This Estimate	To Date Quantity	To Date Amount
49	Storm Manhole, Type SW-401, 60" Dia	EA	1	\$4,005.00	\$ 4,005.00	-	-	1.00	\$ 4,005.00
50	Storm Manhole, Type SW-401, 48" Dia with SW-504 Type 4B Grate ***	EA	1	\$2,795.00	\$ 2,795.00	-	-	1.00	\$ 2,795.00
51	Storm Intake, Type SW-601	EA	1	\$3,075.00	\$ 3,075.00	-	-	0.50	\$ 1,537.50
52	Storm Intake, Type SW-605	EA	2	\$3,705.00	\$ 7,410.00	-	-	1.00	\$ 3,705.00
53	Storm Intake, Type SW-509	EA	4	\$3,945.00	\$ 15,780.00	-	-	2.00	\$ 7,990.00
54	Storm Intake, Type SW-510	EA	1	\$4,965.00	\$ 4,965.00	-	-	1.00	\$ 4,965.00
55	Storm Intake, Type SW-511	EA	1	\$3,075.00	\$ 3,075.00	-	-	1.00	\$ 3,075.00
56	Storm Intake, Type SW-512, 24"	EA	3	\$890.00	\$ 2,670.00	-	-	2.00	\$ 1,780.00
57	Storm Intake, Type SW-541 with SW-542 Extensions Both Directions	EA	1	\$6,151.00	\$ 6,151.00	-	-	0.50	\$ 3,075.50
58	Storm Intake, Type SW-545 (12)	EA	3	\$5,905.00	\$ 17,715.00	-	-	1.50	\$ 10,207.50
59	Storm Intake, Type SW-545 (14)	EA	2	\$7,130.00	\$ 14,260.00	-	-	1.00	\$ 7,130.00
60	Manhole Adjustment, Minor	EA	4	\$1,150.00	\$ 4,600.00	-	-	-	-
61	Connect to Existing Storm Structure	EA	1	\$1,295.00	\$ 1,295.00	-	-	1.00	\$ 1,295.00
62	Remove Existing Storm Manhole or Intake	EA	16	\$675.00	\$ 10,800.00	-	-	16.00	\$ 10,800.00
63	PCC Pavement, 6"	SY	897	\$34.00	\$ 30,498.00	-	-	-	-
64	PCC Pavement, 7"	SY	4787	\$35.25	\$ 168,741.75	4,460.00	\$ 157,215.00	4,740.00	\$ 167,085.00
65	PCC Curb and Gutter, 24" Wide	LF	300	\$34.50	\$ 10,350.00	-	-	281.00	\$ 9,694.50
66	HMA Base, 3/4" Mixture, 300K ESAL	TONS	110	\$110.00	\$ 12,100.00	-	-	-	-
67	HMA Surface, 1/2" Mixture, 300K ESAL	TONS	55	\$110.00	\$ 6,050.00	-	-	-	-
68	HMA Binder, PG 64-22	TONS	10	\$110.00	\$ 1,100.00	-	-	-	-
69	Composite Pavement, Highway 22, 3" HMA on 7" PCC	SY	83	\$129.00	\$ 10,624.00	-	-	121.00	\$ 15,488.00
70	Removal of Sidewalk	SY	657	\$5.85	\$ 3,843.45	357.00	\$ 2,088.45	657.00	\$ 3,843.45
71	Removal of Paved Driveway	SY	324	\$7.50	\$ 2,430.00	174.00	\$ 1,479.00	324.00	\$ 2,430.00
72	Sidewalk, PCC, 5"	SY	338	\$45.00	\$ 15,210.00	-	-	-	-
73	Thickened Edge Sidewalk, PCC, 5"	SY	256	\$100.00	\$ 25,600.00	169.00	\$ 16,900.00	169.00	\$ 16,900.00
74	Reinforced Sidewalk, PCC, 5"	SY	92	\$85.00	\$ 7,820.00	-	-	86.00	\$ 7,310.00
75	Reinforced Sidewalk, PCC, 6"	SY	42	\$85.00	\$ 3,570.00	-	-	-	-
76	Detectable Warnings	SF	212	\$35.00	\$ 7,420.00	-	-	-	-
77	PCC Driveway, 6"	SY	474	\$46.00	\$ 21,804.00	-	-	-	-
78	Removal of Pavement	SY	3,905	\$6.45	\$ 25,167.25	-	-	3,905.00	\$ 25,167.25
79	Bituminous Seal Coat	SY	503	\$4.00	\$ 2,012.00	-	-	-	-
80	Sod	SQ	360	\$50.00	\$ 18,000.00	-	-	-	-
81	Plants, Allowance **	LS	0	\$10,000.00	\$ -	-	-	-	-
82	Planting Bed, 4" Shredded Hardwood Mulch on 12" Imported Topsoil **	SF	0	\$5.25	\$ -	-	-	-	-
83	SWPPP Management	LF	1	\$2,000.00	\$ 2,000.00	-	-	0.50	\$ 1,000.00
84	Filler Sock, 18"	LF	500	\$3.00	\$ 1,500.00	-	-	-	-
85	Removal of Filter Sock	LF	500	\$1.00	\$ 500.00	-	-	-	-
86	Inlet Protection Device	EA	20	\$50.00	\$ 1,000.00	-	-	-	-
87	Inlet Protection Device Maintenance	EA	20	\$25.00	\$ 500.00	-	-	-	-
88	Modular Block Retaining Wall	SF	105	\$34.00	\$ 3,570.00	-	-	-	-
89	PCC Steps	SY	3	\$620.00	\$ 1,860.00	-	-	-	-
90	PCC Steps, 48" Wide, 6" High	EA	1	\$1,500.00	\$ 1,500.00	-	-	-	-
91	Handrail for Steps, Black Powder Coat	LF	10	\$150.00	\$ 1,500.00	-	-	-	-
92	Decorative Railing	LF	155	\$138.00	\$ 21,390.00	-	-	-	-
93	Painted Pavement Markings, Waterborne or Solvent	STA	23.98	\$60.00	\$ 1,438.80	-	-	-	-
94	Decorative Retaining Wall	LF	160	\$1,162.00	\$ 185,920.00	6.00	\$ 9,900.00	152.00	\$ 176,624.00
95	Light Pole Base, LF-201	EA	6	\$1,650.00	\$ 9,900.00	-	-	6.00	\$ 9,900.00
96	Electrical Conduit, 2" PVC	LF	1,296	\$13.00	\$ 16,848.00	-	-	1,296.00	\$ 16,848.00
97	Hand Hole, LI-103, Type II	EA	6	\$1,000.00	\$ 6,000.00	6.00	\$ 6,000.00	6.00	\$ 6,000.00
	TOTAL CONTRACT				\$ 1,309,499.93		\$ 242,395.60		\$ 1,022,878.58
C.O. #1	Water Main, 8" DIP With Nitrite Gaskets	LF	150.000	\$84.90	\$ 15,184.00	-	-	150.00	\$ 15,184.00
	TOTAL CHANGE C.O. #1				\$ 15,184.00				\$ 15,184.00
C.O. #2	Lower Existing 4" Water Main and Install DIP Pipe Materials for Existing LUJST Plume	LS	1.000	\$6,719.25	\$ 6,719.25	-	-	1.00	\$ 6,719.25
	TOTAL CHANGE C.O. #2				\$ 6,719.25				\$ 6,719.25
C.O. #3	Sanitary Sewer Manhole	EA	2.000	\$3,855.00	\$ 7,710.00	-	-	2.00	\$ 7,710.00

Item No.	Item Description	Units	Contract Quantity	Unit Price	Contract Amount	Quantity This Estimate	Amount This Estimate	To Date Quantity	To Date Amount
	8" PVC SDR26 Sanitary Sewer	LF	97,000	\$84.50	\$ 8,196.50	-	-	97,000	\$ 8,196.50
	8" PVC 9000 Sanitary Sewer	LF	20,000	\$178.00	\$ 3,560.00	-	-	20,000	\$ 3,560.00
	4" Sanitary Sewer Service 22 LF	EA	2,000	\$1,785.00	\$ 3,570.00	-	-	2,000	\$ 3,570.00
	Remove Sanitary Sewer Main	LF	117,000	\$9.00	\$ 1,053.00	-	-	117,000	\$ 1,053.00
	Remove Sanitary Sewer Manhole	EA	1,000	\$870.00	\$ 870.00	-	-	1,000	\$ 870.00
	Remove Sanitary Sewer Service	EA	2,000	\$535.00	\$ 1,070.00	-	-	2,000	\$ 1,070.00
	Trench Connection Testing	LS	1,000	\$650.00	\$ 650.00	-	-	1,000	\$ 650.00
	TOTAL CHANGE C.O. #3				\$ 26,679.50				\$ 26,679.50
C.O. #4	Sanitary Sewer Manhole (Material Only)	LS	1,000	\$1,285.00	\$ 1,285.00	1.00	\$ 1,285.00	1.00	\$ 1,285.00
	6" Sanitary Sewer Service	EA	3,000	\$2,650.00	\$ 7,950.00	3.00	\$ 7,950.00	3.00	\$ 7,950.00
	Locate Existing Sewer Service	EA	3,000	\$350.00	\$ 1,050.00	3.00	\$ 1,050.00	3.00	\$ 1,050.00
	45 Degree Water Main Bends	EA	2,000	\$640.00	\$ 1,280.00	2.00	\$ 1,280.00	2.00	\$ 1,280.00
	TOTAL CHANGE C.O. #4				\$ 11,595.00		\$ 11,595.00		\$ 11,595.00
C.O. #5	Install Conduit and Meter Sockets for Relocation of Overhead Electric to Underground	LS	1,000	\$10,780.00	\$ 10,780.00	0.50	\$ 5,390.00	1.00	\$ 10,780.00
	TOTAL CHANGE C.O. #5				\$ 10,780.00		\$ 5,390.00		\$ 10,780.00
C.O. #6	Stamped and Colored Concrete Sidewalk, 5" Thick	LS	49,000	\$209.00	\$ 10,241.00	-	-	-	-
	TOTAL CHANGE C.O. #6				\$ 10,241.00		-		-
C.O. #7	Temporary Retaining Wall and P.C.C. Sidewalks in Highway 22	LS	1,000	\$2,706.00	\$ 2,706.00	1.00	\$ 2,706.00	1.00	\$ 2,706.00
	TOTAL CHANGE C.O. #7				\$ 2,706.00		\$ 2,706.00		\$ 2,706.00
C.O. #8	Add Reinforcing Steel to Thickened Edge Sidewalk	LS	1,000	\$3,236.00	\$ 3,236.00	1.00	\$ 3,236.00	1.00	\$ 3,236.00
	TOTAL CHANGE C.O. #8				\$ 3,236.00		\$ 3,236.00		\$ 3,236.00
C.O. #9	Relocate Water Main South of DMH #2	LS	1,000	\$4,793.09	\$ 4,793.09	1.00	\$ 4,793.09	1.00	\$ 4,793.09
	TOTAL CHANGE C.O. #9				\$ 4,793.09		\$ 4,793.09		\$ 4,793.09
C.O. #10	Adjust Storm Intakes	LS	1,000	\$559.35	\$ 559.35	1.00	\$ 559.35	1.00	\$ 559.35
	TOTAL CHANGE C.O. #10				\$ 559.35		\$ 559.35		\$ 559.35
C.O. #11	SW-402 Intake 60"x60"	EA	1,000	\$5,920.00	\$ 5,920.00	1.00	\$ 5,920.00	1.00	\$ 5,920.00
	TOTAL CHANGE C.O. #11				\$ 5,920.00		\$ 5,920.00		\$ 5,920.00
	TOTAL CONTRACT WITH CHANGE ORDERS				\$ 1,407,913.12		\$ 276,895.04		\$ 1,111,050.77

* Items Changed with Change Order #1
 ** Items Changed with Change Order #6
 *** Items Changed with Change Order #11

Pay Estimate #1 \$ 115,284.21
 Pay Estimate #2 \$ 404,550.38
 Pay Estimate #3 \$ 272,896.37

Total Value of Completed Work Less Retainage \$ 1,055,498.23
 Retainage 5% \$ 55,562.54
 Previous Payments \$ 792,732.94
 Current Payment Due \$ 262,765.29



Date: August 14, 2017

To: Riverside Council

From: Bill Stukey, Operator

O & M Report: July 2017

Water Operation & Maintenance

- Painted fire hydrants, concrete barriers and vents for clear well at the water plant. Both well heads were also painted.
- Results from lead and copper testings were received, all were within limits. Results were mailed to homeowners who participated and filed with DNR in Des Moines.
- 13 locates, completed.

Wastewater Operation & Maintenance

- Recycled used U.V. lamps
- Sludge transfer pump had a bad solenoid valve and wasn't allowing sludge to be transferred to aerobic digester. Result was a bad connection to the solenoid, fixed the connection and is operational again.
- Painted yellow concrete barriers, vents on ISAM tank, and doors at the wastewater plant
- Electric Pump pulled pump 1 from lift station #1, and pump 2 from lift station #2. VFD's were showing an overtemp alarm. Cause of the overtemp alarms were some rags had gotten through the trash basket and partially clogged the pump. Pump was cleaned out and put back in service. Trash baskets were cleaned and noted to be about half full, most likely filled up as a result of sewer cleaning a week prior. Contents of debris was mostly baby / disinfecting wipes.
- Cleaned all trash baskets and lined with a finer mesh screen to prevent rags from falling through. This will result in more frequent clean out of the trash baskets.



- U.V. was pulled for manual cleaning and inspection. Units are in good shape and automatic wipers are functioning properly. During inspection PSI staff found a broken quartz sleeve just below the seal. Sleeve was replaced and all units are back in service.
- Visu-Sewer was on site for annual sewer cleaning (per contract). They noted a few spots with heavy debris and one possible blockage. PSI staff will be obtaining a quote to televise those areas. 12,924 feet of sewer were cleaned.

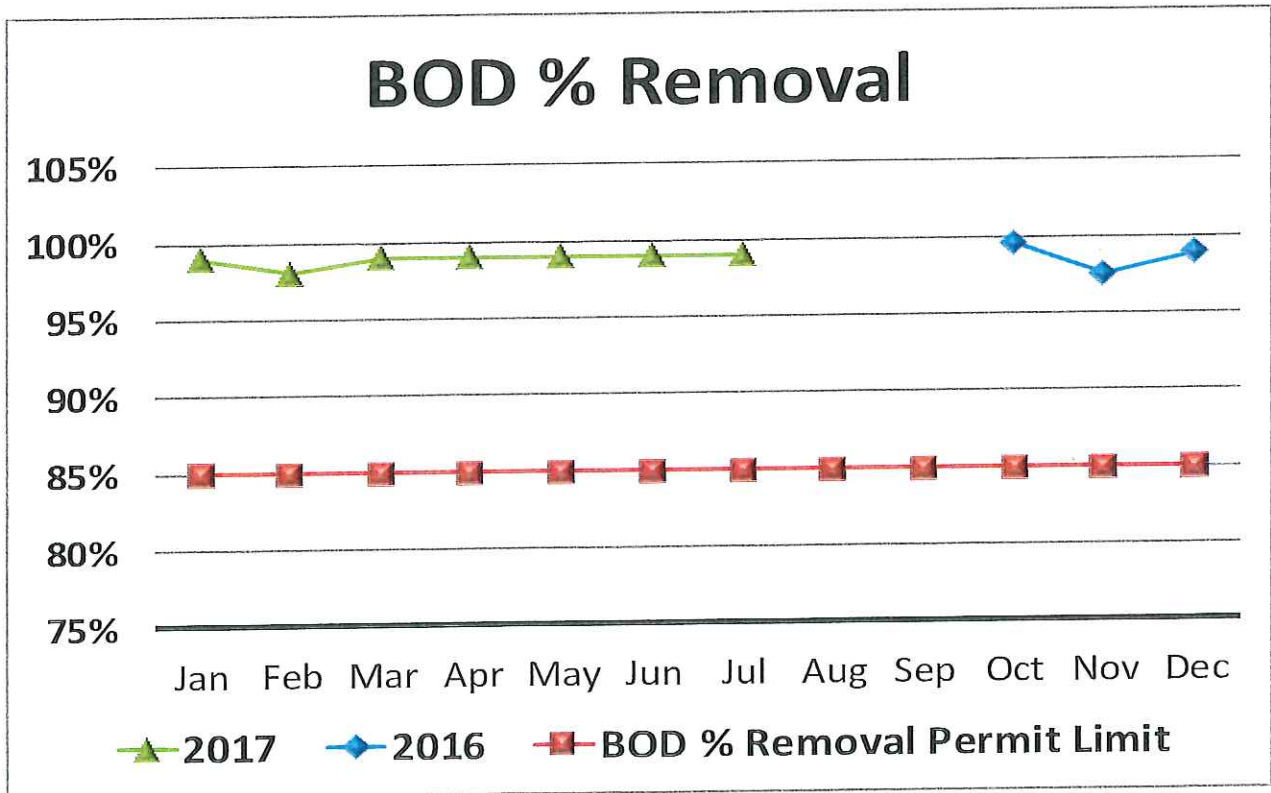
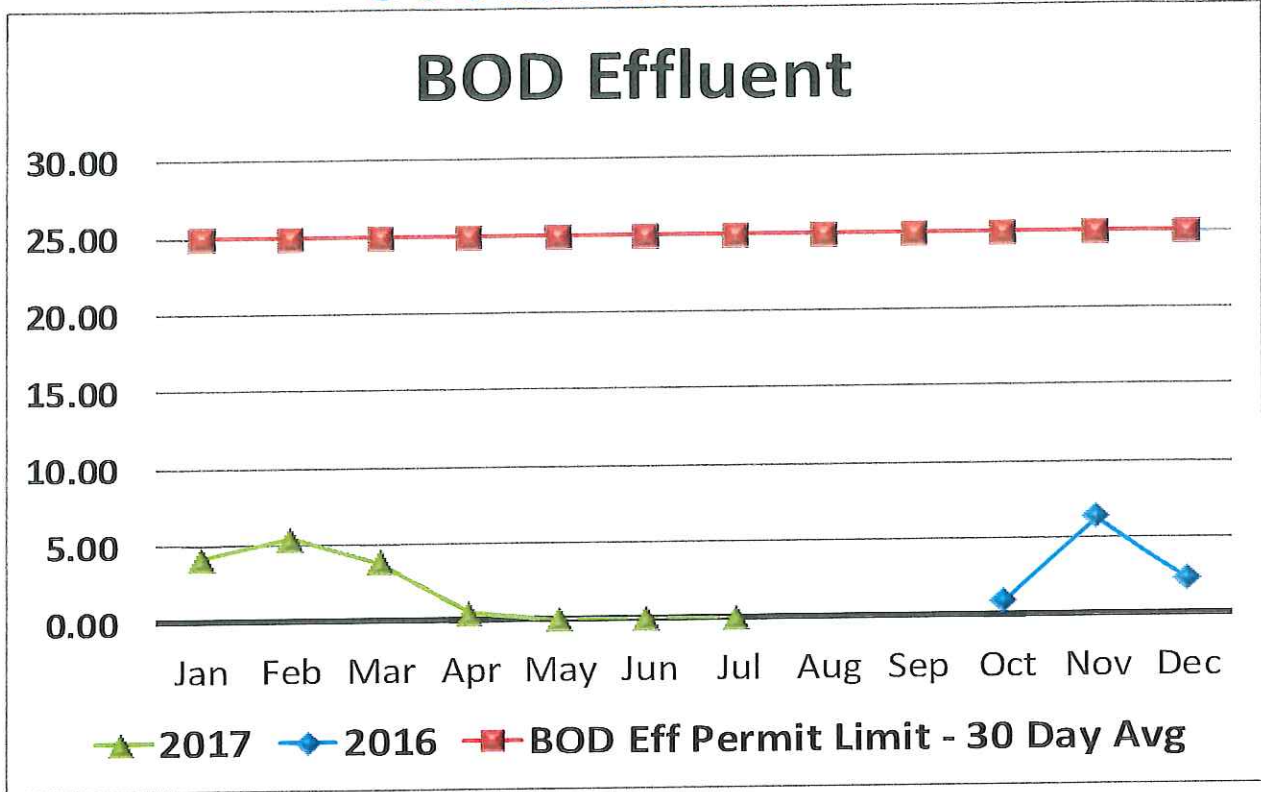

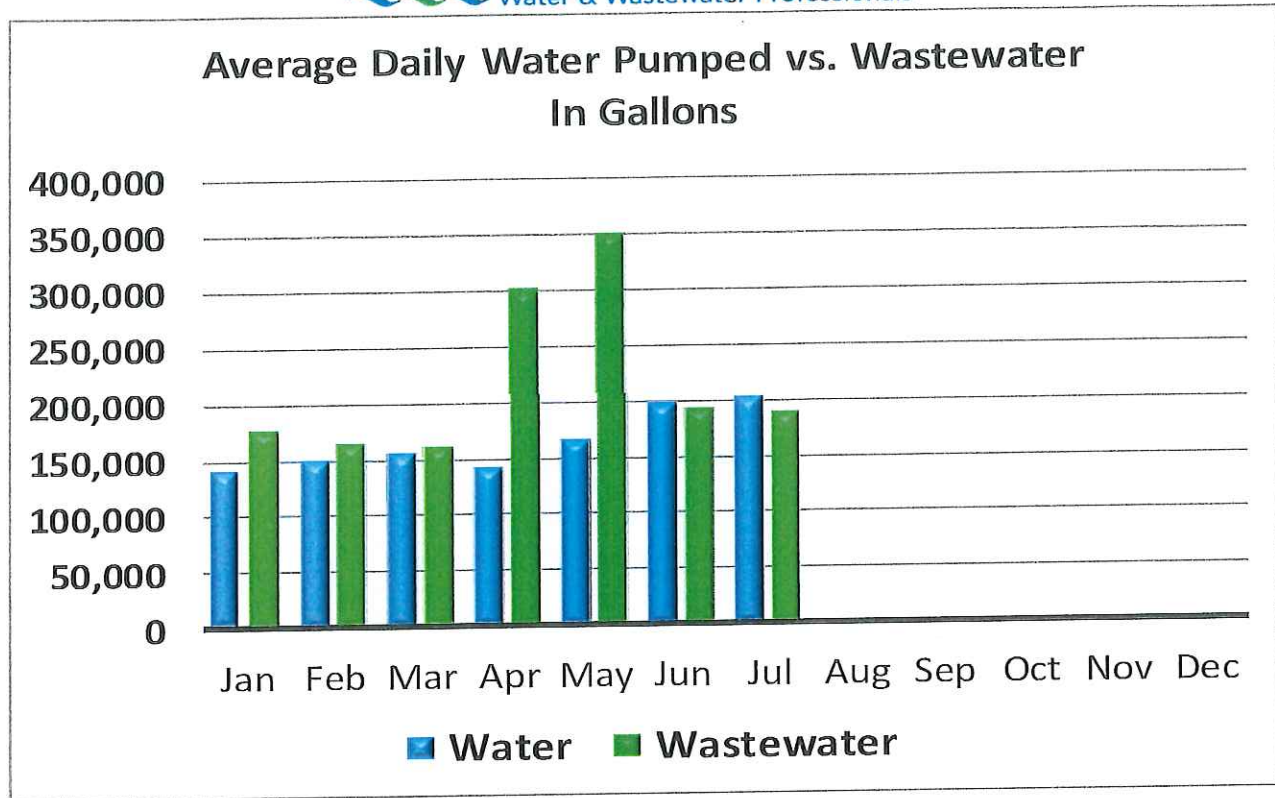

Contract True-Ups - Current Contract Year				
Item	Budgeted Amount	Amount Spent	% of Budget	% of Time
Chemical Budget	\$24,576.00	\$2,448.30	10%	11%
Maintenance Budget	\$20,480.00	\$298.23	1%	11%
Total	\$45,056.00	\$2,746.53	6%	11%



		July-17	June-17	July-16
Water				
	Units			
Total Monthly Pumped	gallons	6,293,000	5,966,000	0
Average Daily Pumped	gallons	203,000	198,870	0
Maximum Daily Pumped	gallons	536,000	540,000	0
Minimum Daily Pumped	gallons	0	0	0
Chlorine				
Chlorine - Total Avg Residual Plant	mg/L	1.39	2.13	0.00
Chlorine - Total Avg Residual System	mg/L	1.45	1.35	0.00
Chlorine - Recommended Residual System	mg/L	0.30	0.30	0.30
Chlorine used	lbs	212.00	194.00	0.00
Iron				
Iron - Avg Raw	mg/L	1.51	1.43	0.00
Polyphosphate				
Polyphosphate - Avg Residual	mg/L	1.43	1.04	0.00
Polyphosphate - Recommended Residual	mg/L	0.5 - 2.0	0.5 - 2.0	0.5 - 2.0
Polyphosphate used	lbs	16.00	17.00	0.00
Water Loss				
Water Billed	gallons	0	0	0
Water used in main breaks/hydrant flushing	gallons	0	0	0
Water used at city buildings	gallons	0	0	0
Loss	gallons	100%	100%	#DIV/0!
Wastewater				
BOD				
BOD Influent Avg	mg/L	256	207	0
BOD Effluent Avg	mg/L	0	0.0	0
BOD Eff Permit Limit - 30 Day Avg	mg/L	25	25	25
BOD % Removal	%	99.00%	99.00%	0.00%
BOD % Removal Permit Limit	%	85%	85%	85%
TSS				
TSS Influent Avg	mg/L	312	186	0
TSS Effluent Avg	mg/L	2	5	0
TSS Effluent Permit Limit - 30 Day Avg	mg/L	30	30	30
TSS % Removal	%	99.36%	97.30%	#DIV/0!
TSS % Removal Permit Limit	%	85%	85%	85%
Nitrogen Ammonia				
NA Effluent Avg	mg/L	0	0	0
NA Effluent Permit Limit - 30 Day Avg	mg/L	5	4	5
Influent Flow				
Total Monthly	gallons	5,943,900	5,776,900	0
Average Daily	gallons	191,738	192,563	0
Maximum Daily	gallons	348,700	286,800	0
Minimum Daily	gallons	142,800	149,300	0
Permit Limit - 30 Day Avg	gallons	444,000	444,000	444,000
Permit Limit - Daily Maximum	gallons	1,425,000	1,425,000	1,425,000



RIVERSIDE - JULY '17

Water Plant Maintenance

<u>Date</u>	<u>Vendor List</u>	<u>Description</u>	<u>Total</u>
7/31/17	First National Bank, VISA	Cartridge Filter Gaskets	\$88.93
Total			\$88.93

Water System Maintenance

<u>Date</u>	<u>Vendor List</u>	<u>Description</u>	<u>Total</u>
7/31/17	Keystone Labs	Lead & Copper Mailing	\$41.25
7/31/17	First National Bank, VISA	Hydrant Paint	\$158.29
Total			\$199.54

Wastewater Plant Maintenance

<u>Date</u>	<u>Vendor List</u>	<u>Description</u>	<u>Total</u>
7/31/17	First National Bank, VISA	Supplies	\$9.76
Total			\$9.76

Wastewater System Maintenance

<u>Date</u>	<u>Vendor List</u>	<u>Description</u>	<u>Total</u>
Total			\$0.00

Water Plant Maintenance	\$88.93
Water System Maintenance	\$199.54
WW Plant Maintenance	\$9.76
WW System Maintenance	\$0.00
Month Total	\$298.23

Annual Maintenance Budget \$20,480.00

Total Maintenance Dollars Spent Year to Date \$298.23

Percent Maintenance Budget Spent Year to Date 1%



RIVERSIDE - JULY '17

Water System Chemicals

<u>Date</u>	<u>Vendor List</u>	<u>Description</u>	<u>Total</u>
7/28/17	Hawkins	Sodium Hypochlorite	\$168.75
7/28/17	Hawkins	Poly Phosphate	\$124.30
7/28/17	Hawkins	Dosium Hydroxide and Vitec	\$2,155.25
Total			\$2,448.30

Wastewater System Chemicals

<u>Date</u>	<u>Vendor List</u>	<u>Description</u>	<u>Total</u>
Total			\$0.00

Water System Chemicals	\$2,448.30
W/W System Chemicals	\$0.00
Month Total	\$2,448.30

Annual Chemical Budget \$24,576.00

Total Chemical Dollars Spent Year to Date \$2,448.30

Percent Chemical Budget Spent Year to Date 10%

Maintenance Month Total	\$298.23
Chemical Month Total	\$2,448.30
Month Total	\$2,746.53

Annual Budget \$45,056.00

Total Spent Year to Date \$2,746.53

Percent Budget Spent Year to Date 6%



Completed Work Order List Report

Completed	Equipment Name	Task	WO#
7/5/2017	5310-BLW-1	MONTHLY PREVENTATIVE MAINTENANCE	14103
7/5/2017	5310-BLW-2	MONTHLY PREVENTATIVE MAINTENANCE	14103
7/5/2017	5310-BLW-3	MONTHLY PREVENTATIVE MAINTENANCE	14103
7/5/2017	5310-FE	MONTHLY PREVENTATIVE MAINTENANCE	14104
7/5/2017	5310-GEN	MONTHLY PREVENTATIVE MAINTENANCE	14105
7/5/2017	5310-LS-MAIN	MONTHLY-PM	14106
7/5/2017	5310-LS-1	MONTHLY-PM	14107
7/5/2017	5310-LS-2	MONTHLY-PM	14107
7/5/2017	5310-LS-3	MONTHLY-PM	14107
7/5/2017	5310-LS-4	MONTHLY-PM	14107
7/5/2017	5310-LS-5	MONTHLY-PM	14107
7/5/2017	5310-SAMP-EFF	MONTHLY PREVENTATIVE MAINTENANCE	14108
7/5/2017	5310-SAMP-INF	MONTHLY PREVENTATIVE MAINTENANCE	14109
7/5/2017	5310-SCREEN	MONTHLY PREVENTATIVE MAINTENANCE	14110
7/5/2017	5310-UV	MONTHLY PREVENTATIVE MAINTENANCE	14111
7/5/2017	6310-DEH	MONTHLY PREVENTATIVE MAINTENANCE	14149
7/5/2017	6310-FE	MONTHLY PREVENTATIVE MAINTENANCE	14150
7/5/2017	6310-FIL-BAG-1	MONTHLY PREVENTATIVE MAINTENANCE	14151
7/5/2017	6310-FIL-BAG-2	MONTHLY PREVENTATIVE MAINTENANCE	14151
7/5/2017	6310-FIL-CART-1	MONTHLY PREVENTATIVE MAINTENANCE	14152
7/5/2017	6310-FIL-CART-2	MONTHLY PREVENTATIVE MAINTENANCE	14152
7/5/2017	6310-FIL-CART-3	MONTHLY PREVENTATIVE MAINTENANCE	14152
7/5/2017	6310-GEN	MONTHLY PREVENTATIVE MAINTENANCE	14153
7/5/2017	6310-PUM-HS-1	MONTHLY PREVENTATIVE MAINTENANCE	14155
7/5/2017	6310-PUM-HS-2	MONTHLY PREVENTATIVE MAINTENANCE	14155
7/5/2017	6310-PUM-HS-3	MONTHLY PREVENTATIVE MAINTENANCE	14155
7/5/2017	6310-PUM-HS-4	MONTHLY PREVENTATIVE MAINTENANCE	14155
7/3/2017	6310-HTR	PREVENTATIVE MAINTENANCE	14154



Office: W230 N4855 Betker Drive
Pewaukee, WI 53072-1430
Phone: 262-695-2340
Fax: 262-695-2359
E-Mail: visu-info@visu-sewer.com

CLEANING REPORT

PROJECT: Riverside, IA

JOB NO: 17240IA-03

CREW LEADER: Charles Hart

UPSTREAM MANHOLE: 10

LOCATION: Boise Street

PIPE SIZE: 8"

COMMENTS: Light Cleaning

DOWNSTREAM MANHOLE: 11

DATE OF WORK: 7/18/2017

LENGTH: 295

UPSTREAM MANHOLE: 11

LOCATION: First Street

PIPE SIZE: 8"

COMMENTS: Light Cleaning

DOWNSTREAM MANHOLE: 14

DATE OF WORK: 7/18/2017

LENGTH: 205

UPSTREAM MANHOLE: 11

LOCATION: First Street

PIPE SIZE: 8"

COMMENTS: Light Cleaning

DOWNSTREAM MANHOLE: 12

DATE OF WORK: 7/18/2017

LENGTH: 355

UPSTREAM MANHOLE: 12

LOCATION: Kinsel Street

PIPE SIZE: 8"

COMMENTS: Light Cleaning

DOWNSTREAM MANHOLE: 12.1

DATE OF WORK: 7/18/2017

LENGTH: 355

UPSTREAM MANHOLE: 14

LOCATION: Boise Street

PIPE SIZE: 8"

COMMENTS: Light Cleaning

DOWNSTREAM MANHOLE: 15

DATE OF WORK: 7/18/2017

LENGTH: 295

UPSTREAM MANHOLE: 15

LOCATION: Boise Street

PIPE SIZE: 8"

COMMENTS: Light Cleaning

DOWNSTREAM MANHOLE: 16

DATE OF WORK: 7/18/2017

LENGTH: 140

UPSTREAM MANHOLE: 16

LOCATION: Boise Street

PIPE SIZE: 8"

COMMENTS: Heavy Cleaning

DOWNSTREAM MANHOLE: 19

DATE OF WORK: 7/13/2017

LENGTH: 234

PROJECT: Riverside, IA

JOB NO: 17240IA-03

CREW LEADER: Charles Hart

UPSTREAM MANHOLE: 16

LOCATION: Oak Street

PIPE SIZE: 8"

COMMENTS: Light Cleaning

DOWNSTREAM MANHOLE: 17

DATE OF WORK: 7/18/2017

LENGTH: 145

UPSTREAM MANHOLE: 17

LOCATION: Oak Street

PIPE SIZE: 8"

COMMENTS: Light Cleaning

DOWNSTREAM MANHOLE: 18

DATE OF WORK: 7/18/2017

LENGTH: 230

UPSTREAM MANHOLE: 19

LOCATION: Boise Street

PIPE SIZE: 8"

COMMENTS: Heavy Cleaning

DOWNSTREAM MANHOLE: 20

DATE OF WORK: 7/13/2017

LENGTH: 227

UPSTREAM MANHOLE: 20

LOCATION: Boise Street

PIPE SIZE: 8"

COMMENTS: Medium Cleaning

DOWNSTREAM MANHOLE: 21

DATE OF WORK: 7/13/2017

LENGTH: 203

UPSTREAM MANHOLE: 22

LOCATION: Washington Street

PIPE SIZE: 8"

COMMENTS: Light Cleaning

DOWNSTREAM MANHOLE: 23

DATE OF WORK: 7/18/2017

LENGTH: 282

UPSTREAM MANHOLE: 22

LOCATION: Rail Road Street

PIPE SIZE: 10"

COMMENTS: Light Cleaning

DOWNSTREAM MANHOLE: 38

DATE OF WORK: 7/19/2017

LENGTH: 380

UPSTREAM MANHOLE: 23

LOCATION: Washington Street

PIPE SIZE: 8"

COMMENTS: Light Cleaning

DOWNSTREAM MANHOLE: 23A

DATE OF WORK: 7/12/2017

LENGTH: 362

UPSTREAM MANHOLE: 23A

LOCATION: 2nd Street

PIPE SIZE: 8"

COMMENTS: Light Cleaning

DOWNSTREAM MANHOLE: 28

DATE OF WORK: 7/12/2017

LENGTH: 305

UPSTREAM MANHOLE: 23A

LOCATION: Washington Street

PIPE SIZE: 8"

COMMENTS: Light Cleaning

DOWNSTREAM MANHOLE: 27

DATE OF WORK: 7/12/2017

LENGTH: 180

PROJECT: Riverside, IA

JOB NO: 172401A-03

CREW LEADER: Charles Hart

UPSTREAM MANHOLE: 24

LOCATION: First Street

PIPE SIZE: 8"

COMMENTS: Medium Cleaning

DOWNSTREAM MANHOLE: 23

DATE OF WORK: 7/20/2017

LENGTH: 370

UPSTREAM MANHOLE: 25

LOCATION: First Street

PIPE SIZE: 8"

COMMENTS: Light Cleaning

DOWNSTREAM MANHOLE: 24

DATE OF WORK: 7/20/2017

LENGTH: 370

UPSTREAM MANHOLE: 27

LOCATION: Washington Street

PIPE SIZE: 8"

COMMENTS: Light Cleaning

DOWNSTREAM MANHOLE: 29

DATE OF WORK: 7/12/2017

LENGTH: 185

UPSTREAM MANHOLE: 29

LOCATION: Washington Street

PIPE SIZE: 8"

COMMENTS: Light Cleaning

DOWNSTREAM MANHOLE: 31

DATE OF WORK: 7/12/2017

LENGTH: 360

UPSTREAM MANHOLE: 29

LOCATION: 3rd Street

PIPE SIZE: 8"

COMMENTS: Light Cleaning

DOWNSTREAM MANHOLE: 30

DATE OF WORK: 7/12/2017

LENGTH: 310

UPSTREAM MANHOLE: 31

LOCATION: 4th Street

PIPE SIZE: 8"

COMMENTS: Light Cleaning

DOWNSTREAM MANHOLE: 32

DATE OF WORK: 7/12/2017

LENGTH: 240

UPSTREAM MANHOLE: 32

LOCATION: 4th Street

PIPE SIZE: 8"

COMMENTS: Light Cleaning

DOWNSTREAM MANHOLE: 32.1

DATE OF WORK: 7/12/2017

LENGTH: 400

UPSTREAM MANHOLE: 32.1

LOCATION: 4th Street

PIPE SIZE: 8"

COMMENTS: Light Cleaning

DOWNSTREAM MANHOLE: 33

DATE OF WORK: 7/12/2017

LENGTH: 115

UPSTREAM MANHOLE: 33

LOCATION: Washburn Street

PIPE SIZE: 8"

COMMENTS: Light Cleaning

DOWNSTREAM MANHOLE: 34

DATE OF WORK: 7/12/2017

LENGTH: 175

PROJECT: Riverside, IA

JOB NO: 172401A-03

CREW LEADER: Charles Hart

UPSTREAM MANHOLE: 34
LOCATION: Stomarys Street
PIPE SIZE: 8"
COMMENTS: Light Cleaning

DOWNSTREAM MANHOLE: 35
DATE OF WORK: 7/12/2017
LENGTH: 425

UPSTREAM MANHOLE: 35
LOCATION: Elm Street
PIPE SIZE: 8"
COMMENTS: Heavy Cleaning

DOWNSTREAM MANHOLE: 36
DATE OF WORK: 7/11/2017
LENGTH: 525

UPSTREAM MANHOLE: 36
LOCATION: Vine Street
PIPE SIZE: 8"
COMMENTS: Heavy Cleaning

DOWNSTREAM MANHOLE: 37
DATE OF WORK: 7/11/2017
LENGTH: 125

UPSTREAM MANHOLE: 38
LOCATION: Rail Road Street
PIPE SIZE: 8"
COMMENTS: Medium Cleaning

DOWNSTREAM MANHOLE: 39
DATE OF WORK: 7/19/2017
LENGTH: 396

UPSTREAM MANHOLE: 39
LOCATION: Rail Road Street
PIPE SIZE: 8"
COMMENTS: Medium Cleaning

DOWNSTREAM MANHOLE: 40
DATE OF WORK: 7/19/2017
LENGTH: 288

UPSTREAM MANHOLE: 4
LOCATION: River Street
PIPE SIZE: 10"
COMMENTS: Light Cleaning

DOWNSTREAM MANHOLE: 5
DATE OF WORK: 7/19/2017
LENGTH: 322

UPSTREAM MANHOLE: 40
LOCATION: First Street
PIPE SIZE: 10"
COMMENTS: Medium Cleaning

DOWNSTREAM MANHOLE: 41
DATE OF WORK:
LENGTH: 515

UPSTREAM MANHOLE: 41
LOCATION: First Street
PIPE SIZE: 10"
COMMENTS: Light Cleaning

DOWNSTREAM MANHOLE: 42
DATE OF WORK:
LENGTH: 515

UPSTREAM MANHOLE: 42
LOCATION: First Street
PIPE SIZE: 10"
COMMENTS: Light Cleaning

DOWNSTREAM MANHOLE: 47
DATE OF WORK:
LENGTH: 165

PROJECT: Riverside, IA

JOB NO: 17240IA-03

CREW LEADER: Charles Hart

UPSTREAM MANHOLE: 43
 LOCATION: Second Street
 PIPE SIZE: 8"
 COMMENTS: Light Cleaning

DOWNSTREAM MANHOLE: 42
 DATE OF WORK:
 LENGTH: 400

UPSTREAM MANHOLE: 47
 LOCATION: First Street
 PIPE SIZE: 10"
 COMMENTS: Light Cleaning

DOWNSTREAM MANHOLE: 48
 DATE OF WORK:
 LENGTH: 100

UPSTREAM MANHOLE: 48
 LOCATION: Hickory
 PIPE SIZE: 10"
 COMMENTS: Light Cleaning

DOWNSTREAM MANHOLE: 49
 DATE OF WORK: 7/19/2017
 LENGTH: 100

UPSTREAM MANHOLE: 49
 LOCATION: Hickory
 PIPE SIZE: 10"
 COMMENTS: Light Cleaning

DOWNSTREAM MANHOLE: 64
 DATE OF WORK: 7/19/2017
 LENGTH: 250

UPSTREAM MANHOLE: 5
 LOCATION: River Street
 PIPE SIZE: 10"
 COMMENTS: Light Cleaning

DOWNSTREAM MANHOLE: 6
 DATE OF WORK: 7/19/2017
 LENGTH: 375

UPSTREAM MANHOLE: 6
 LOCATION: River Street
 PIPE SIZE: 10"
 COMMENTS: Light Cleaning

DOWNSTREAM MANHOLE: 7
 DATE OF WORK: 7/19/2017
 LENGTH: 350

UPSTREAM MANHOLE: 7
 LOCATION: Bike Path
 PIPE SIZE: 10"
 COMMENTS: Light Cleaning

DOWNSTREAM MANHOLE: 8
 DATE OF WORK: 7/19/2017
 LENGTH: 200

UPSTREAM MANHOLE: 7
 LOCATION: River Street
 PIPE SIZE: 10"
 COMMENTS: Light Cleaning

DOWNSTREAM MANHOLE: 22
 DATE OF WORK: 7/19/2017
 LENGTH: 260

UPSTREAM MANHOLE: 79
 LOCATION: River Street
 PIPE SIZE: 10"
 COMMENTS: Light Cleaning

DOWNSTREAM MANHOLE: 78
 DATE OF WORK: 7/19/2017
 LENGTH: 380

PROJECT: Riverside, IA

JOB NO: 17240IA-03

CREW LEADER: Charles Hart

UPSTREAM MANHOLE: 79

DOWNSTREAM MANHOLE: 48

LOCATION: Hickory

DATE OF WORK: 7/19/2017

PIPE SIZE: 10"

LENGTH: 215

COMMENTS: Light Cleaning

UPSTREAM MANHOLE: 8

DOWNSTREAM MANHOLE: 9

LOCATION: Bike Path

DATE OF WORK: 7/19/2017

PIPE SIZE: 10"

LENGTH: 300

COMMENTS: Light Cleaning



ELECTRIC PUMP

Offices:

**4280 E 14th Street
Des Moines, IA 50313
Office: 515-265-2222
Toll Free: (800)-383-7867
Fax: 515-265-8079**

**201 4th Ave SW
New Prague, MN 56071
Office: 952-758-6600
Toll Free: 800-536-5394
Fax: 952-758-7778**

April 28, 2017

Peoples Service
Riverside, Iowa

Mr. Bill Stukey
BStukey@peopleservice.com
319-530-3730
319-800-3281.

REFERENCE: Omni Site Cellular Alarm Monitor

Please find detailed below a formal quotation on a Multimedia Alarm Management System and Remote Site Wireless Lift Station Analyzer as manufactured by Omni Site for your use and consideration.

Omni Site Crystal Ball EN

ITEM A

One (1) Crystal Ball Plus Multimedia Alarm Management System Remote Site Wireless Lift Station Analyzer/Equipment Monitor with internal battery, charger, phantom antenna in polycarbonate enclosure suitable for operation on 120 Volt power and installation at your existing station/remote site.

Each controller shall accept (14) universal DI configurable to monitor dry contacts or any voltage range between 12VDC/VAC to 120 VAC/VDC or to act as pulse counters; (4) 4-20mA isolated analog inputs, (4) 20 amp relay outputs, (1)rain gauge input, and (1) crew on-site intelligent key reader input in its base form. It shall have Phoenix type removable terminal blocks.

One (1) Lot Labor and Materials for complete system installation at the water plant, wastewater plant, Lift Station #1, #2, and #4

The above item A, FOB factory, one (1) year warranty from date of startup not to exceed 18 months from date of shipment.

Hardware Only, No Installation

- One (1) Lift Station #1 - \$3,265.00
- One (1) Lift Station #2 - \$3,265.00
- One (1) Lift Station #4 - \$3,265.00
- One (1) Water Plant - \$3,825.00
- One (1) Wastewater Plant - \$3,825.00

Notes:

Pricing for the Installation of each unit will vary depending on units purchased, which will determine time and travel to Riverside, Iowa

Approximate Installation Cost for Lift Station \$775.00

Approximate Installation Cost for WWTP and WTP with 50' extend antenna cable is \$1055.00

Water Plant has 40 Inputs wired into the existing Sensaphone, Omni Site has 11 inputs, plus 3 for pumps

Wastewater Plant has 16 Inputs wired into the existing Sensaphone, Omni Site has 11 inputs, plus 3 for pumps

Includes alarm notifications via e-mail, page or voice, and daily report. A limited Web page which shows the (Pump-GPM), (Pump-Runtime) (Pump-Starts), (Total station daily flow).

Should you have any questions on the above, please do not hesitate to contact us at your first convenience.

Respectfully submitted:



David D. Bloch
Project Management

Cc: John Leto

NOTES:

The above price does not include any:

- Sales or use taxes
- Installation
- Cellular Fees of any kind
- Pump Station maintenance
- Pipe, valve, fittings of any kind
- Bond costs – if required
- License fees or permits of any kind
- Anything not specifically mentioned

Delivery: 2-4 weeks after submittal approval (Submittals 1-4 weeks) if applicable.

Payment: Net 30 Days – Retainage upon completion

We are pleased to make the following offer to sell the listed Merchandise which is firm for (30) thirty days from the above date, and is automatically withdrawn thereafter without any further notice.

1. Signing and returning this document to Electric Pump's office in Minneapolis office may accept this offer.
2. This offer and acceptance constitutes the entire Agreement between the parties and may be modified only by a writing signed by both parties.
3. The prices quoted for equipment are valid for (30) thirty days. If the quote includes start up services and it is scheduled by the request of the buyer for a time other than Monday through Friday 8:00 to 5:00 additional charges will be due.
4. Payment terms are NET 30 (thirty days) after the mailing of seller's invoice.
5. Delivery terms are F.O.B. Place of Shipment. Seller agrees to put the merchandise in the possession of the carrier, to make a reasonable contract of carriage for their transportation, to obtain and deliver or tender such documents as may be necessary to enable Buyer to obtain possession, and to promptly notify the Buyer of shipment. After seller has delivered the merchandise to the carrier, the risk of loss of the merchandise will be borne by the Buyer. The prices quoted herein include transportation charges based on existing truckload rates, any change in delivery rates existing at the time of delivery will be billed to your account. Dates of delivery are determined from the date of Seller's acceptance of any order or orders by Buyer and are estimates of approximate dates of delivery, not a guaranty of a particular day of delivery.
6. Sales and use tax are not included.
7. Buyer shall notify seller in writing at Seller's place of business as shown on the reverse side of this page, within twenty (20) days of receipt of merchandise, or any complaint whatsoever buyer may have concerning such merchandise. Failure to give such notice shall constitute a waiver by Buyer of all claims in respect to such goods.
8. If notice of complaints is provided within twenty (20) days of Buyer's receipt of the merchandise, Seller agrees to inspect the merchandise at Seller's place of business during Seller's normal business hours and days. Upon inspection, if the merchandise is determined to be defective in material or workmanship, Seller, at Seller's option, shall repair or replace said merchandise at no cost to Buyer, or Seller may refund the purchase price. If the examined merchandise is found not to be defective or is not for some other reason within the warranty coverage, Seller's service time expended on and off-location will be charged to Buyer.
9. Seller will have no further warranty obligation under this Agreement if the Equipment is subjected to abuse, misuse, negligence or accident or if buyer fails to perform any of its duties set forth in Paragraphs 8 and 9.
10. THE WARRANTY PRINTED ABOVE IS THE ONLY WARRANTY MADE BY THE SELLER REGARDING THIS PURCHASE. SELLER DISCLAIMS ALL OTHER WARRANTIES, EXPRESS OR IMPLIED, INCLUDING, BUT NOT LIMITED TO, THE

IMPLIED WARRANTIES OF MERCHANTABILITY AND FITNESS FOR A PARTICULAR PURPOSE. NOTHING HEREIN CONTAINED SHALL LIMIT BUYER'S RIGHTS AGAINST THE MANUFACTURER, WITH RESPECT TO MANUFACTURER'S WARRANTIES, IF ANY.

- 11. WARRANTY REPAIRS (which fall under the manufacturer's warranty, if any) ARE F.O.B. ELECTRIC PUMP, INC. SERVICE LOCATION. ELECTRIC PUMP, INC. WILL NOT ASSUME ANY EXTENDED WARRANTIES UNLESS APPROVED BY PRIOR WRITTEN CONSENT. THIS INCLUDES SERVICE CALLS TO JOB SITES ON PRODUCT COVERED DURING THE WARRANTY PERIOD. PLEASE REFER TO THE ATTACHED PRODUCT WARRANTY STATEMENT FOR CLARIFICATION.
- 12. IT IS UNDERSTOOD AND AGREED THAT SELLER'S LIABILITY WHETHER IN CONTRACT, IN TORT, UNDER ANY WARRANTY, IN NEGLIGENCE OR OTHERWISE SHALL NOT EXCEED THE RETURN OF THE AMOUNT OF THE PURCHASE PRICE PAID BY BUYER AND UNDER NO CIRCUMSTANCES SHALL SELLER BE LIABLE FOR SPECIAL, INDIRECT OR CONSEQUENTIAL DAMAGES. THE PRICE STATED FOR THE MERCHANDISE IS A CONSIDERATION IN LIMITING SELLER'S LIABILITY. NO ACTION, REGARDLESS OF FORM, ARISING OUT OF THE TRANSACTION UNDER THIS AGREEMENT MAY BE BROUGHT BY BUYER MORE THAN ONE-YEAR AFTER THE CAUSE OF ACTION HAS ACCRUED.
- 13. This Agreement shall be governed by and interpreted in accordance with the laws of the State of Iowa. Any dispute or disputes arising between the parties hereunder, insofar as the same cannot be settled by friendly agreement, shall be litigated only in The Iowa District Court for Polk County, in Des Moines, Iowa. Seller also has the right to commence an action against the Buyer in the County of the Buyer's principal place of business.

Purchase Order Number _____

Purchase Order Amount _____

SIGNATURE _____

DATE _____

****A signed copy of this must be returned with your P.O.**



310 CENTER COURT - VENICE, FLORIDA 34285
 P: (941) 488-9671 | F: (941) 488-9400
www.harnrosystems.com

City of Riverside WTP	ATTN: Bill Stukey	07/28/2017
3126 Highway 22	BStukey@peopleservice.com	
Riverside, IA 52327	2 nd Stage Membrane Replacement Proposal	

Harn R/O Systems is pleased to present this proposal for supply of 2nd Stage Membrane Replacement. The proposal has two options available. Option 1 will include only the materials supplied for the membranes such as the membranes, interconnectors, and replacement end cap adapters. Option 2 will include material, installation labor, and travel expenses.

Option 1

Description	QTY	Price
FilmTec NF90-400/34i Membrane	63	\$41,816.25
Pressure Vessel End Cap Adapters	18	\$747.69
□ Option 1 – Material Only - Total of.....		\$42,563.94

Option 2

Description	Price
Material (Membranes & End Adapters)	\$42,563.94
Installation Assistance and Supervision & Travel Expenses	\$9,236.06

The following items are including with the installation:

- One (1) Senior RO technician
- Engineering assistance to set up projections, review startup data, and prepare final report
- Assistance in unloading old membranes
- Cleaning and disinfecting pressure vessels prior to installation of new membranes
- Prepping the membranes by lubricating, staging the membranes, recording loading sequence
- Profiling the Trains at Start-up after new membranes are installed

This proposal EXCLUDES bacteriological clearance and water quality testing. Owner is responsible for disposal of old membranes and unloading shipment of new membranes

□ Option 2 – Material & Installation Supervision + Assistance - Total of.....	\$51,800.00
--	--------------------

Plus freight, bonds, and sales tax excluded.
 Lead time is 6-8 weeks upon receipt of order.

We Propose hereby to furnish material and labor – complete in accordance with above specifications, for the sum of:
See above, taxes not included Terms are Net 30 days

All materials is guaranteed to be as specified. All work to be completed in a workmanlike manner according to standard practices. Any alteration or deviation from above specifications involving extra costs will be executed only upon written orders, and will become an extra charge over and above the estimate. All agreements contingent upon strikes, accidents or delays beyond our control. Owner to carry fire, tornado and other necessary insurance. Our workers are fully covered by Workmen's Compensation Insurance.

Authorized

Signature Andrey Kharitonenko

NOTE: This proposal may be
Withdrawn by us if not accepted within 30 days.

Acceptance of Proposal - The above prices, specifications and conditions are satisfactory and are hereby accepted. You are authorized to do the work as specified. Payment will be made as outlined above.

Signature _____

Signature: _____

Date of Acceptance: _____

Payment terms are 30 days from invoice date unless otherwise agreed upon in writing.
 Remit to: Cummins Central Power
 PO Box 310397
 Des Moines, IA 50331-0397



Sales and Service

CEDAR RAPIDS
 625 33RD AVE. SW
 CEDAR RAPIDS, IA 52404-
 (319)366-7537

INVOICE NO
ESTIMATE
REMIT TO: PO Box 310397 Des Moines, IA 50331-0397

BILL TO

CITY OF RIVERSIDE
 21 E 1ST ST
 RIVERSIDE, IA 52327-

OWNER

CITY OF RIVERSIDE
 21 E 1ST ST
 RIVERSIDE, IA 52327-
 BILL STUKEY - 319 8003281

PAGE 1 OF 2

*** CASH ***

DATE	CUSTOMER ORDER NO.	DATE IN SERVICE	ENGINE MODEL	PUMP NO.	EQUIPMENT MAKE
14-AUG-2017 09:20AM			D125P1		OLYMPIAN
CUSTOMER NO.	SHIP VIA	FAIL DATE	ENGINE SERIAL NO.	CPL NO.	EQUIPMENT MODEL
566038		14-AUG-2017	NAT00599		D125P1
REF. NO.	SALESPERSON	PARTS DISP.	MILEAGE/HOURS	PUMP CODE	UNIT NO.
55284					LIFT STATION 1

QUANTITY ORDERED	BACK ORDERED	QUANTITY SHIPPED	PART NUMBER	DESCRIPTION	PRODUCT CODE	UNIT PRICE	AMOUNT
			OSN/MSN/VIN	NAT00599			
			COMPLAINT	CUSTOMER COMPLAINING OF UNIT SLOW TO START			
			CAUSE	DURING SERVICE TECH T/SHOT AND THINKING THERE IS A RESTRICTION IN FUEL TANK			
			CORRECTION	TECH IS RECOMMENDING FUEL POLISH			
			COVERAGE	BILLABLE REPAIR			
			REMARK	8-14-17 9:30 AM EMAILED QUOTE TO BILL ROUGHLY TOTALING \$1690.81 EXPLAINED QUOTE WAS ON THE HIGH SIDE WOULD ONLY BILL WHAT THE TECH HAS IN THE JOB LAF			
13		0	AFC-705	FUEL CATALYST, (OUNCE)	OTHER	2.10	27.30
2		0	WB-10AZ	10 MICRON WTR BLOCK FLTR	OTHER	57.60	115.20
2		0	WB-3AZ	3 MICRON WATER FILTER	OTHER	61.44	122.88
				PARTS:			265.38
				PARTS COVERAGE CREDIT:			0.00 CR
				TOTAL PARTS:		265.38	
				SURCHARGE TOTAL:			0.00
				LABOR:			1,218.00
				LABOR COVERAGE CREDIT:			0.00 CR
				TOTAL LABOR:		1,218.00	
				MISC.:			105.06
				MISC. COVERAGE CREDIT:			0.00 CR
				TOTAL MISC.:		105.06	
				SHOP SUPPLIES			78.40
				HAZ WASTE DISPOSAL			49.00
				ELECTRONIC TOOLING FEE			0.00
				NON-TAXABLE MILEAGE			126.00

Completion date : 14-Aug-2019 08:52AM. Estimate expires : 13-Sep-2017 08:52AM.

Billing Inquiries? Call (877)480-6970 or email CBSCentralPower.Receivables@cummins.com

THERE ARE ADDITIONAL CONTRACT TERMS ON THE REVERSE SIDE OF THIS DOCUMENT, INCLUDING LIMITATION ON WARRANTIES AND REMEDIES, WHICH ARE EXPRESSLY INCORPORATED HEREIN AND WHICH PURCHASER ACKNOWLEDGES HAVE BEEN READ AND FULLY UNDERSTOOD.

LIMITED EXPRESS WARRANTY

Cummins Inc. hereby warrants Cummins REBUILT EXCHANGE ENGINES, REBUILT EXCHANGE COMPONENTS, OR SERVICE WORK to be free from defects in material and workmanship under normal maintenance and service which are discovered and repaired by Cummins within the period of time, miles, or hours, whichever shall first occur after delivery to the Buyer (Owner), or upon completion of SERVICE WORK and upon conditions hereafter set forth. Cummins's liability shall be limited to repairing or, at its option, replacing any Cummins's rebuilt exchange engines and rebuilt components which satisfaction was defective in material or workmanship and that it is returned with transportation charges prepaid, to Cummins, or an authorized distributor or Dealer of Cummins Inc., within the warranty period as hereinafter set forth. Authorization by Cummins is required prior to such repair being performed and no other express warranty is given. No agent, employee or representative of Cummins is authorized to bind Cummins for any such other warranty.

Owner is responsible for all labor charges incurred for removing and reinstalling the engines or assemblies when that becomes necessary to effectuate the particular repair or replacement. Cummins may use the option, at its sole discretion, to assume the cost of said labor.

Warranty coverage is limited to only those parts that are listed on invoice that were used to perform repair. Unless the Owner shall issue specific instructions to the contrary. Cummins will only replace the parts considered necessary for continued operation at a minimum cost to the Owner. Any castings, forgings, or other original parts reused in the repair or rebuilding of an assembly or engine are not covered by this warranty.

ICE WORK coverage is limited to only work done in any Cummins repair facility or by an authorized Cummins employee and provides reasonable labor at a Cummins facility to repair or, at the sole discretion of Cummins's replacement of failed engine components or parts caused by Cummins faulty workmanship.

Warranty shall not apply with respect to any claimed defect which in Cummins's sole judgement has arisen from repair or alteration by anyone other than Cummins, or from accident, negligence or misuse, including, but not limited to, the following: Operation at a speed exceeding rated speed or loading beyond the rated load capacity; operation without adequate coolant, fuel or lubricants; lack of maintenance of cooling, lubricating or air intake systems; improper warm-up, run-in or shutdown practices; lack of normal maintenance services such as engine tune-up and repair or replacement of filters, belts; or overfueling.

Owner is responsible for all costs of oil, fuel, grease, fluids, anti-freeze, fuses, bulbs, filter elements, hoses, belts and other maintenance items replaced during repair.

Cummins shall not be liable for any loss of time to the Owner while the engine assembly or other equipment is out of commission. Nor shall Cummins be liable for any commercial losses or costs of any kind, including, but not limited to, "down time" expenses, towing charges, cargo damage, communication expenses, meals, lodging and other incidental costs incurred by Owner or employees of Owner.

II. USED PARTS LIMITED EXPRESS WARRANTY

Cummins hereby warrants to its original Buyer (Owner) its used parts to be free from defects in material and workmanship under normal use, maintenance and service, which are discovered and reported to Cummins within thirty (30) days after date of invoice to the Owner. Cummins's total responsibility hereunder shall be limited to replacing the defective part with another used part or, at Cummins's election, the amount paid by the Owner for the part will be refunded.

III. NON-CUMMINS PARTS, COMPONENTS AND ASSEMBLIES

It is understood by the Owner that Cummins may be furnishing parts, components and assemblies that are obtained from and manufactured by entities other than Cummins including, but not limited to, Cummins Inc. and Diesel ReCon Co. Cummins offers NO express or implied warranties, including the WARRANTY OF MERCHANTABILITY AND FITNESS FOR A PARTICULAR PURPOSE, covering components, parts or accessories manufactured by someone other than Cummins. Such warranties as may be furnished to Cummins or the Owner by the manufacturer of such items will be extended to the Owner and administered by Cummins to the extent allowed by the manufacturer.

IV. WARRANTY STATEMENT DISCLAIMER AND LIMITATIONS OF LIABILITY

WARRANTY DISCLAIMER. THE RESPECTIVE REMEDIES HEREINBEFORE SET FORTH IN THE APPLICABLE EXPRESS WARRANTY SHALL BE THE EXCLUSIVE AND SOLE REMEDIES OF THE OWNER. THERE ARE NO IMPLIED WARRANTIES THAT THE EQUIPMENT, COMPONENT PARTS OF ENGINES COVERED BY THIS EXPRESS WARRANTY ARE OF MERCHANTABILITY OR THAT THEY ARE FIT FOR ANY PARTICULAR PURPOSE.

LIMITATION OF LIABILITY. THE LIABILITY OF CUMMINS FOR ANY AND ALL CLAIMS, LOSSES AND DAMAGES TO OWNER RESULTING FROM ANY CAUSE WHATSOEVER (INCLUDING LIABILITY FOR NEGLIGENCE AND STRICT LIABILITY) WITH RESPECT TO ALLEGED DAMAGED OR DEFECTIVE PARTS, DAMAGED OR DEFECTIVE ENGINES AND IMPROPER SERVICING, REGARDLESS OF WHETHER SUCH CLAIMS ARE DISCOVERABLE OR LATENT, SHALL IN NO EVENT EXCEED THE PURCHASE PRICE OF THE PARTICULAR PARTS OR SERVICES WITH RESPECT TO WHICH SUCH CLAIMS OR DAMAGES ARE CLAIMED, OR, AT THE ELECTION OF CUMMINS, THE REPAIR OR REPLACEMENT OF DEFECTIVE OR DAMAGED PARTS OR ENGINES IN NO EVENT, INCLUDING THE REPAIR OR REPLACEMENT OF A CLAIM OF NEGLIGENCE OR STRICT LIABILITY SHALL CUMMINS BE LIABLE FOR ANY SPECIAL, INCIDENTAL OR CONSEQUENTIAL DAMAGES, EVEN IF CUMMINS SHALL HAVE BEEN ADVISED OF THE POSSIBILITY OF SUCH POTENTIAL LOSS OR DAMAGE.

TERMS: 100% CORE CREDIT WHEN CORE IS RETURNED WITHIN 45 DAYS OF PURCHASE. 95% CORE CREDIT WHEN CORE IS RETURNED WITHIN 46-90 DAYS OF PURCHASE. NO CORE CREDIT AFTER 90 DAYS OF PURCHASE.

FOLLOWING SCHEDULES APPLY TO:

	Miles	Hours	Months	Material	Labor
Rebuilt Exchange Engines	0-25,000	0-900	0-3	100%	100%
Rebuilt Exchange Components	0-25,000	0-900	0-3	100%	100%
Ice Work	0-25,000	0-900	0-3	0	100%
Rebuilt Parts	Not Applicable	Not Applicable	30 days	See Above	0

Warranty is based on miles, hours, or time, whichever first occurs.

CUSTOMER SERVICE CENTERS

REGIONAL OFFICE

38 So. 136th St. Omaha, NE 68138 (402) 551-7678 (402) 551-1952	1680 N.E. 51st Ave. P.O.Box B Des Moines, IA 50316 (515) 262-9591 Fax (515) 262-0626	625 33rd Ave. S.W. 625 33rd Ave SW Cedar Rapids, IA 52404 (319) 366-7537 Fax (319) 366-7562	701 E. 54th St. No. Sioux Falls, SD 57104 (605) 336-1715 Fax (605) 336-1748	515 Central Ave. P.O. Box 1326 Kearney, NE 68848 (308) 234-1994 Fax (308) 234-5776	7820 42nd St. W. P.O.Box 4445 Rock Island, IL 61204 (309) 787-4300 Fax (309) 787-4397	Integration Center 2402 SE Hulsizer Dr Ankeny, IA 50021 (515) 264-1650 Fax (515) 264-1651
8201 NE Parvin Road Kansas City, MO 64161 (816) 414-8200 Fax (816) 414-8299	3637 East Kearney Springfield, MO 65803 (417) 862-0777 Fax (417) 862-4429	1285 Acraway Garden City, KS 67846 (620) 275-2277 Fax (620) 275-2533	4915 E. 32nd P.O. Box 4675 Joplin, MO 64804 (417) 623-1661 Fax (417) 623-1817	1880 South Range Colby, KS 67701 (785) 462-3945 Fax (785) 462-3970	5101 North Broadway Wichita, KS 67219 (316) 838-0875 Fax (316) 838-0704	

Important information about Cummins engines:

Using this engine for any purpose other than for its intended application provided on the engine's dataplate may be a violation of federal law subject to civil penalty.

ReCon engines cannot be installed in new vehicle or equipment. ReCon engine to be installed is to be of the same or newer model year as the model year of the engine, or engine with aftertreatment system, it is replacing, or if this is unknown, the model year of the vehicle or equipment in which it is to be used.

Payment terms are 30 days from invoice date unless otherwise agreed upon in writing.

Remit to: Cummins Central Power
PO Box 310397
Des Moines, IA 50331-0397



Sales and Service

CEDAR RAPIDS
625 33RD AVE. SW
CEDAR RAPIDS, IA 52404-
(319)366-7537

INVOICE NO
ESTIMATE
REMIT TO: PO Box 310397 Des Moines, IA 50331-0397

BILL TO

CITY OF RIVERSIDE
21 E 1ST ST
RIVERSIDE, IA 52327-

OWNER

CITY OF RIVERSIDE
21 E 1ST ST
RIVERSIDE, IA 52327-
BILL STUKEY - 319 8003281

PAGE 2 OF 2

*** CASH ***

DATE	CUSTOMER ORDER NO.	DATE IN SERVICE	ENGINE MODEL	PUMP NO.	EQUIPMENT MAKE
14-AUG-2017 09:20AM			D125P1		OLYMPIAN
CUSTOMER NO.	SHIP VIA	FAIL DATE	ENGINE SERIAL NO.	CPL NO.	EQUIPMENT MODEL
566038		14-AUG-2017	NAT00599		D125P1
REF. NO.	SALESPERSON	PARTS DISP.	MILEAGE/HOURS	PUMP CODE	UNIT NO.
55284					LIFT STATION 1

QUANTITY ORDERED	BACK ORDERED	QUANTITY SHIPPED	PART NUMBER	DESCRIPTION	PRODUCT CODE	UNIT PRICE	AMOUNT
			NAT00599	OSN/MSN/VIN			
				PM CONTRACT DISCOUNT		-	148.34
					LOCAL		14.62
					STATE		87.75

DIESEL PARTICULATE FILTER CLEANING AVAILABLE AT MOST OF OUR CUMMINS CENTRAL POWER LOCATIONS
NO RETURNS FOR INSTALLED ELECTRONIC PARTS

Completion date : 14-Aug-2019 08:52AM. Estimate expires : 13-Sep-2017 08:52AM.

Billing Inquiries? Call (877)480-6970 or email CBSCentralPower.Receivables@cummins.com

THERE ARE ADDITIONAL CONTRACT TERMS ON THE REVERSE SIDE OF THIS DOCUMENT, INCLUDING LIMITATION ON WARRANTIES AND REMEDIES, WHICH ARE EXPRESSLY INCORPORATED HEREIN AND WHICH PURCHASER ACKNOWLEDGES HAVE BEEN READ AND FULLY UNDERSTOOD.

SUB TOTAL:	1,588.44
TOTAL TAX:	102.37
TOTAL AMOUNT: US \$	1,690.81

-59-
SIGNATURE

DATE

AUTHORIZED BY (print name)

LIMITED EXPRESS WARRANTY

Cummins Inc., hereby warrants Cummins REBUILT EXCHANGE ENGINES, REBUILT EXCHANGE COMPONENTS, OR SERVICE WORK to be free from defects in material and workmanship under normal maintenance and service which are discovered and repaired by Cummins within the period of time, miles, or hours, whichever shall first occur after delivery to the Buyer (Owner), or upon completion of SERVICE WORK and upon conditions hereafter set forth. Cummins's liability shall be limited to repairing or, at its option, replacing any Cummins's rebuilt exchange engines and rebuilt components which satisfaction was defective in material or workmanship and that it is returned with transportation charges prepaid, to Cummins, or an authorized distributor or Dealer of Cummins Inc., within the warranty period as hereinafter set forth. Authorization by Cummins is required prior to such repair being performed and no other express warranty is given. No agent, employee or representative of Cummins is authorized to bind Cummins for any such other warranty. The Owner is responsible for all labor charges incurred for removing and reinstalling the engines or assemblies when that becomes necessary to effectuate the particular repair or replacement. Cummins may, at its option, at its sole discretion, to assume the cost of said labor. The warranty coverage is limited to only those parts that are listed on invoice that were used to perform repair. Unless the Owner shall issue specific instructions to the contrary. Cummins will only replace the parts considered necessary for continued operation at a minimum cost to the Owner. Any castings, forgings, or other original parts reused in the repair or rebuilding of an assembly or engine are not covered by this warranty.

ICE WORK coverage is limited to only work done in any Cummins repair facility or by an authorized Cummins employee and provides reasonable labor at a Cummins facility to repair or, at the sole discretion of Cummins's replacement of failed engine components or parts caused by Cummins faulty workmanship.

This warranty shall not apply with respect to any claimed defect which in Cummins's sole judgement has arisen from repair or alteration by anyone other than Cummins, or from accident, negligence or misuse, including, but not limited to, the following: Operation at a speed exceeding rated speed or loading beyond the rated load capacity; operation without adequate coolant, fuel or lubricants; lack of maintenance of cooling, lubricating or air intake systems; improper warm-up, run-in or shutdown practices; lack of normal maintenance services such as engine tune-up and repair or replacement of filters, belts; or overfueling.

The Owner is responsible for all costs of oil, fuel, grease, fluids, anti-freeze, fuses, bulbs, filter elements, hoses, belts and other maintenance items replaced during repair.

Cummins shall not be liable for any loss of time to the Owner while the engine assembly or other equipment is out of commission. Nor shall Cummins be liable for any commercial losses or costs of any kind, including, but not limited to, "down time" expenses, towing charges, cargo damage, communication expenses, meals, lodging and other incidental costs incurred by Owner or employees of Owner.

II. USED PARTS LIMITED EXPRESS WARRANTY

Cummins hereby warrants to its original Buyer (Owner) its used parts to be free from defects in material and workmanship under normal use, maintenance and service, which are discovered and reported to Cummins within thirty (30) days after date of invoice to the Owner. Cummins's total responsibility hereunder shall be limited to replacing the defective part with another used part or, at Cummins's election, the amount paid by the Owner for the part will be refunded.

III. NON-CUMMINS PARTS, COMPONENTS AND ASSEMBLIES

It is understood by the Owner that Cummins may be furnishing parts, components and assemblies that are obtained from and manufactured by entities other than Cummins including, but not limited to, Cummins Inc. and Diesel ReCon Co. Cummins offers NO express or implied warranties, including the WARRANTY OF MERCHANTABILITY AND FITNESS FOR A PARTICULAR PURPOSE, covering components, parts or accessories manufactured by someone other than Cummins. Such warranties as may be furnished to Cummins or the Owner by the manufacturer of such items will be extended to the Owner and administered by Cummins to the extent allowed by the manufacturer.

IV. WARRANTY STATEMENT DISCLAIMER AND LIMITATIONS OF LIABILITY

THE RESPECTIVE REMEDIES HEREINBEFORE SET FORTH IN THE APPLICABLE EXPRESS WARRANTY SHALL BE THE EXCLUSIVE AND SOLE REMEDIES OF THE OWNER. THERE ARE NO IMPLIED WARRANTIES THAT THE EQUIPMENT, COMPONENT PARTS OF ENGINES COVERED BY THIS EXPRESS WARRANTY ARE OF MERCHANTABILITY OR THAT THEY ARE OF ANY PARTICULAR PURPOSE.

CUMMINS DISCLAIMS LIABILITY FOR ANY AND ALL CLAIMS, LOSSES AND DAMAGES TO OWNER RESULTING FROM ANY CAUSE WHATSOEVER (INCLUDING LIABILITY FOR NEGLIGENCE AND STRICT LIABILITY) WITH RESPECT TO ALLEGED DAMAGED OR DEFECTIVE PARTS, DAMAGED OR DEFECTIVE ENGINES AND IMPROPER SERVICING, REGARDLESS OF WHETHER SUCH CLAIMS ARE DISCOVERABLE OR LATENT, SHALL IN NO EVENT EXCEED THE PURCHASE PRICE OF THE PARTICULAR PARTS OR SERVICES WITH RESPECT TO WHICH SUCH CLAIMS OR DAMAGES ARE CLAIMED, OR, AT THE ELECTION OF CUMMINS, THE REPAIR OR REPLACEMENT OF DEFECTIVE OR DAMAGED PARTS OR ENGINES IN NO EVENT, INCLUDING THE COST OF A CLAIM OF NEGLIGENCE OR STRICT LIABILITY SHALL CUMMINS BE LIABLE FOR ANY SPECIAL, INCIDENTAL OR CONSEQUENTIAL DAMAGES, EVEN IF CUMMINS SHALL HAVE BEEN ADVISED OF THE POSSIBILITY OF SUCH POTENTIAL LOSS OR DAMAGE.

TERMS: 100% CORE CREDIT WHEN CORE IS RETURNED WITHIN 45 DAYS OF PURCHASE. 95% CORE CREDIT WHEN CORE IS RETURNED WITHIN 46-90 DAYS OF PURCHASE. NO CORE CREDIT AFTER 90 DAYS OF PURCHASE.

FOLLOWING SCHEDULES APPLY TO:

	Miles	Hours	Months	Material	Labor
Rebuilt Exchange Engines	0-25,000	0-900	0-3	100%	100%
Rebuilt Exchange Components	0-25,000	0-900	0-3	100%	100%
Ice Work	0-25,000	0-900	0-3	0	100%
Rebuilt Parts	Not Applicable	Not Applicable	30 days	See Above	0

Warranty is based on miles, hours, or time, whichever first occurs.

CUSTOMER SERVICE CENTERS

HOME OFFICE

38 So. 136th St. Omaha, NE 68138 (402) 551-7678 (402) 551-1952	1680 N.E. 51st Ave. P.O.Box B Des Moines, IA 50316 (515) 262-9591 Fax (515) 262-0626	625 33rd Ave. S.W. 625 33rd Ave SW Cedar Rapids, IA 52404 (319) 366-7537 Fax (319) 366-7562	701 E. 54th St. No. Sioux Falls, SD 57104 (605) 336-1715 Fax (605) 336-1748	515 Central Ave. P.O. Box 1326 Kearney, NE 68848 (308) 234-1994 Fax (308) 234-5776	7820 42nd St. W. P.O.Box 4445 Rock Island, IL 61204 (309) 787-4300 Fax (309) 787-4397	Integration Center 2402 SE Hulsizer Dr Ankeny, IA 50021 (515) 264-1650 Fax (515) 264-1651
8201 NE Parvin Road Kansas City, MO 64161 (916) 414-8200 Fax (816) 414-8209	3637 East Kearney Springfield, MO 65803 (417) 862-0777 Fax (417) 862-4429	1285 Acraway Garden City, KS 67846 (620) 275-2277 Fax (620) 275-2533	4915 E. 32nd P.O. Box 4675 Joplin, MO 64804 (417) 623-1661 Fax (417) 623-1817	1800 South Range Colby, KS 67701 (785) 462-3945 Fax (785) 462-3970	5101 North Broadway Wichita, KS 67219 (316) 838-0875 Fax (316) 838-0704	

Important information about Cummins engines:

Using this engine for any purpose other than for its intended application provided on the engine's dataplate may be a violation of federal law subject to civil penalty. Engines cannot be installed in new vehicle or equipment. ReCon engine to be installed is to be of the same or newer model year as the model year of the engine, or engine with aftertreatment system, it is replacing, or if this is unknown, the model year of the vehicle or equipment in which it is to be used.



Sales and Service

Payment terms are 30 days from invoice date unless otherwise agreed upon in writing.

Remit to: Cummins Central Power
PO Box 310397
Des Moines, IA 50331-0397

CEDAR RAPIDS
625 33RD AVE. SW
CEDAR RAPIDS, IA 52404-
(319)366-7537

INVOICE NO
ESTIMATE
REMIT TO: PO Box 310397 Des Moines, IA 50331-0397

BILL TO

CITY OF RIVERSIDE
21 E 1ST ST
RIVERSIDE, IA 52327-

OWNER

LIFT STATION 5
21 E 1ST ST
RIVERSIDE, IA 52327-
BILL STUKEY - 319 8003281

PAGE 1 OF 2

*** CASH ***

DATE	CUSTOMER ORDER NO.	DATE IN SERVICE	ENGINE MODEL	PUMP NO.	EQUIPMENT MAKE
14-AUG-2017 09:21AM			D125P2		OLYMPIAN
CUSTOMER NO.	SHIP VIA	FAIL DATE	ENGINE SERIAL NO.	CPL NO.	EQUIPMENT MODEL
566038		11-AUG-2017	NPS02212		D125P2
REF. NO.	SALESPERSON	PARTS DISP.	MILEAGE/HOURS	PUMP CODE	UNIT NO.
55279					LIFT STATION 5

QUANTITY ORDERED	BACK ORDERED	QUANTITY SHIPPED	PART NUMBER	DESCRIPTION	PRODUCT CODE	UNIT PRICE	AMOUNT
			NPS02212	OSN/MSN/VIN			
				COMPLAINT			
				CAUSE			
				CORRECTION			
				COVERAGE			
				REMARK			
1		0	TPS181GT12-001	BLOCK HEATER	KIM-HOTSTART	137.81	137.81
				PARTS:			137.81
				PARTS COVERAGE CREDIT:			0.00 CR
				TOTAL PARTS:		137.81	
				SURCHARGE TOTAL:			0.00
				LABOR:			546.00
				LABOR COVERAGE CREDIT:			0.00 CR
				TOTAL LABOR:		546.00	
				MISC.:			52.86
				MISC. COVERAGE CREDIT:			0.00 CR
				TOTAL MISC.:		52.86	
				SHOP SUPPLIES			35.84
				HAZ WASTE DISPOSAL			22.40
				ELECTRONIC TOOLING FEE			0.00
				NON-TAXABLE MILEAGE			63.00
				PM CONTRACT DISCOUNT			- 68.38
					LOCAL		6.74

Completion date : 11-Sep-2017 03:03PM. Estimate expires : 10-Sep-2017 03:03PM.

Billing Inquiries? Call (877)480-6970 or email CBSCentralPower.Receivables@cummins.com

THERE ARE ADDITIONAL CONTRACT TERMS ON THE REVERSE SIDE OF THIS DOCUMENT, INCLUDING LIMITATION ON WARRANTIES AND REMEDIES, WHICH ARE EXPRESSLY INCORPORATED HEREIN AND WHICH PURCHASER ACKNOWLEDGES HAVE BEEN READ AND FULLY UNDERSTOOD.

AUTHORIZED BY (print name) _____ -61- SIGNATURE _____ DATE _____

LIMITED EXPRESS WARRANTY

Cummins Inc., hereby warrants Cummins REBUILT EXCHANGE ENGINES, REBUILT EXCHANGE COMPONENTS, OR SERVICE WORK to be free from defects in material and workmanship under normal maintenance and service which are discovered and repaired by Cummins within the period of time, miles, or hours, whichever shall first occur after delivery to the Buyer (Owner), or upon completion of SERVICE WORK and upon conditions hereafter set forth. Cummins's liability shall be limited to repairing or, at its option, replacing any Cummins's rebuilt exchange engines and rebuilt components which satisfaction was defective in material or workmanship and that it is returned with transportation charges prepaid, to Cummins, or an authorized distributor or Dealer of Cummins Inc., within the warranty period as hereinafter set forth. Authorization by Cummins is required prior to such repair being performed and no other express warranty is given. No agent, employee or representative of Cummins is authorized to bind Cummins for any such other warranty.

The Owner is responsible for all labor charges incurred for removing and reinstalling the engines or assemblies when that becomes necessary to effectuate the particular repair or replacement. Cummins may, at its option, at its sole discretion, to assume the cost of said labor.

The warranty coverage is limited to only those parts that are listed on invoice that were used to perform repair. Unless the Owner shall issue specific instructions to the contrary, Cummins will only replace the parts considered necessary for continued operation at a minimum cost to the Owner. Any castings, forgings, or other original parts reused in the repair or rebuilding of an assembly or engine are not covered by this warranty.

WARRANTY coverage is limited to only work done in any Cummins repair facility or by an authorized Cummins employee and provides reasonable labor at a Cummins facility to repair or, at the sole discretion of Cummins's replacement of failed engine components or parts caused by Cummins faulty workmanship.

This warranty shall not apply with respect to any claimed defect which in Cummins's sole judgement has arisen from repair or alteration by anyone other than Cummins, or from accident, negligence or misuse, including, but not limited to, the following: Operation at a speed exceeding rated speed or loading beyond the rated load capacity; operation without adequate coolant, fuel or lubricants; lack of maintenance of cooling, lubricating or air intake systems; improper warm-up, run-in or shutdown practices; lack of normal maintenance services such as engine tune-up and repair or replacement of filters, belts; or overfueling.

The Owner is responsible for all costs of oil, fuel, grease, fluids, anti-freeze, fuses, bulbs, filter elements, hoses, belts and other maintenance items replaced during repair.

Cummins shall not be liable for any loss of time to the Owner while the engine assembly or other equipment is out of commission. Nor shall Cummins be liable for any commercial losses or costs of any kind, including, but not limited to, "down time" expenses, towing charges, cargo damage, communication expenses, meals, lodging and other incidental costs incurred by Owner or employees of Owner.

II. USED PARTS LIMITED EXPRESS WARRANTY

Cummins hereby warrants to its original Buyer (Owner) its used parts to be free from defects in material and workmanship under normal use, maintenance and service, which are discovered and reported to Cummins within thirty (30) days after date of invoice to the Owner. Cummins's total responsibility hereunder shall be limited to replacing the defective part with another used part or, at Cummins's election, the amount paid by the Owner for the part will be refunded.

III. NON-CUMMINS PARTS, COMPONENTS AND ASSEMBLIES

It is understood by the Owner that Cummins may be furnishing parts, components and assemblies that are obtained from and manufactured by entities other than Cummins including, but not limited to, Cummins Inc. and Diesel ReCon Co. Cummins offers NO express or implied warranties, including the WARRANTY OF MERCHANTABILITY AND FITNESS FOR A PARTICULAR PURPOSE, covering components, parts or accessories manufactured by someone other than Cummins. Such warranties as may be furnished to Cummins or the Owner by the manufacturer of such items will be extended to the Owner and administered by Cummins to the extent allowed by the manufacturer.

IV. WARRANTY STATEMENT DISCLAIMER AND LIMITATIONS OF LIABILITY

THE RESPECTIVE REMEDIES HEREINBEFORE SET FORTH IN THE APPLICABLE EXPRESS WARRANTY SHALL BE THE EXCLUSIVE AND SOLE REMEDIES OF THE OWNER. THERE ARE NO IMPLIED WARRANTIES THAT THE EQUIPMENT, COMPONENT PARTS OF ENGINES COVERED BY THIS EXPRESS WARRANTY ARE OF MERCHANTABILITY OR THAT THEY ARE OF ANY PARTICULAR PURPOSE.

NOTWITHSTANDING THE LIMITATION OF LIABILITY, THE LIABILITY OF CUMMINS FOR ANY AND ALL CLAIMS, LOSSES AND DAMAGES TO OWNER RESULTING FROM ANY CAUSE WHATSOEVER (INCLUDING LIABILITY FOR NEGLIGENCE AND STRICT LIABILITY) WITH RESPECT TO ALLEGED DAMAGED OR DEFECTIVE PARTS, DAMAGED OR DEFECTIVE ENGINES AND IMPROPER SERVICING, REGARDLESS OF WHETHER SUCH CLAIMS ARE DISCOVERABLE OR LATENT, SHALL IN NO EVENT EXCEED THE PURCHASE PRICE OF THE PARTICULAR PARTS OR SERVICES WITH RESPECT TO WHICH SUCH DAMAGES ARE CLAIMED. OR, AT THE ELECTION OF CUMMINS, THE REPAIR OR REPLACEMENT OF DEFECTIVE OR DAMAGED PARTS OR ENGINES IN NO EVENT, INCLUDING THE LIMITATION OF A CLAIM OF NEGLIGENCE OR STRICT LIABILITY SHALL CUMMINS BE LIABLE FOR ANY SPECIAL, INCIDENTAL OR CONSEQUENTIAL DAMAGES, EVEN IF CUMMINS SHALL HAVE BEEN ADVISED OF THE POSSIBILITY OF SUCH POTENTIAL LOSS OR DAMAGE.

TERMS: 100% CORE CREDIT WHEN CORE IS RETURNED WITHIN 45 DAYS OF PURCHASE. 95% CORE CREDIT WHEN CORE IS RETURNED WITHIN 46-90 DAYS OF PURCHASE. NO CORE CREDIT AFTER 90 DAYS OF PURCHASE.

FOLLOWING SCHEDULES APPLY TO:

	Miles	Hours	Months	Material	Labor
Rebuilt Exchange Engines	0-25,000	0-900	0-3	100%	100%
Rebuilt Exchange Components	0-25,000	0-900	0-3	100%	100%
Service Work	0-25,000	0-900	0-3	0	100%
Used Parts	Not Applicable	Not Applicable	30 days	See Above	0

Warranty is based on miles, hours, or time, whichever first occurs.

CUSTOMER SERVICE CENTERS

REGIONAL OFFICE

38 So. 136th St. Omaha, NE 68138 (402) 551-7678 (402) 551-1952	1680 N.E. 51st Ave. P.O. Box B Des Moines, IA 50316 (515) 262-9591 Fax (515) 262-0626	625 33rd Ave. S.W. 625 33rd Ave SW Cadara Rapids, IA 52404 (319) 366-7537 Fax (319) 366-7562	701 E. 54th St. No. Sioux Falls, SD 57104 (605) 336-1715 Fax (605) 336-1748	515 Central Ave. P.O. Box 1328 Kearney, NE 68848 (308) 234-1994 Fax (308) 234-5776	7820 42nd St. W. P.O. Box 4445 Rock Island, IL 61204 (309) 787-4300 Fax (309) 787-4397	Integration Center 2402 SE Hulsizer Dr Ankeny, IA 50021 (515) 264-1650 Fax (515) 264-1651
--	--	---	---	---	---	--

8201 NE Parvin Road Kansas City, MO 64161 (816) 414-8200 Fax (816) 414-8299	3637 East Kearney Springfield, MO 65803 (417) 862-0777 Fax (417) 862-4429	1285 Acraway Garden City, KS 67846 (620) 275-2277 Fax (620) 275-2533	4915 E. 32nd P.O. Box 4675 Joplin, MO 64804 (417) 623-1661 Fax (417) 623-1817	1880 South Range Colby, KS 67701 (785) 462-3945 Fax (785) 462-3970	5101 North Broadway Wichita, KS 67219 (316) 838-0875 Fax (316) 838-0704
---	---	--	--	--	---

Important information about Cummins engines:

Using this engine for any purpose other than for its intended application provided on the engine's dataplate may be a violation of federal law subject to civil penalty.

ReCon engines cannot be installed in new vehicle or equipment. ReCon engine to be installed is to be of the same or newer model year as the model year of the engine, or engine with aftertreatment system, it is replacing, or if this is unknown, the model year of the vehicle or equipment in which it is to be used.

Payment terms are 30 days from invoice date unless otherwise agreed upon in writing.

Remit to: Cummins Central Power
 PO Box 310397
 Des Moines, IA 50331-0397



CEDAR RAPIDS
 625 33RD AVE. SW
 CEDAR RAPIDS, IA 52404-
 (319)366-7537

INVOICE NO
ESTIMATE
REMIT TO: PO Box 310397 Des Moines, IA 50331-0397

BILL TO

CITY OF RIVERSIDE
 21 E 1ST ST
 RIVERSIDE, IA 52327-

OWNER

LIFT STATION 5
 21 E 1ST ST
 RIVERSIDE, IA 52327-
 BILL STUKEY - 319 8003281

PAGE 2 OF 2

*** CASH ***

DATE	CUSTOMER ORDER NO.	DATE IN SERVICE	ENGINE MODEL	PUMP NO.	EQUIPMENT MAKE
14-AUG-2017 09:21AM			D125P2		OLYMPIAN
CUSTOMER NO.	SHIP VIA	FAIL DATE	ENGINE SERIAL NO.	CPL NO.	EQUIPMENT MODEL
566038		11-AUG-2017	NPS02212		D125P2
REF. NO.	SALESPERSON	PARTS DISP.	MILEAGE/HOURS	PUMP CODE	UNIT NO.
55279					LIFT STATION 5

QUANTITY ORDERED	BACK ORDERED	QUANTITY SHIPPED	PART NUMBER	DESCRIPTION	PRODUCT CODE	UNIT PRICE	AMOUNT
			NPS02212	OSN/MSN/VIN		40.42	
DIESEL PARTICULATE FILTER CLEANING AVAILABLE AT MOST OF OUR CUMMINS CENTRAL POWER LOCATIONS ***NO RETURNS FOR INSTALLED ELECTRONIC PARTS***							
						STATE	40.42

Completion date : 11-Sep-2017 03:03PM. Estimate expires : 10-Sep-2017 03:03PM.

Billing Inquiries? Call (877)480-6970 or email CBSCentralPower.Receivables@cummins.com

THERE ARE ADDITIONAL CONTRACT TERMS ON THE REVERSE SIDE OF THIS DOCUMENT, INCLUDING LIMITATION ON WARRANTIES AND REMEDIES, WHICH ARE EXPRESSLY INCORPORATED HEREIN AND WHICH PURCHASER ACKNOWLEDGES HAVE BEEN READ AND FULLY UNDERSTOOD.

SUB TOTAL:	736.67
TOTAL TAX:	47.16
TOTAL AMOUNT: US \$	783.83

-63-
SIGNATURE

DATE

AUTHORIZED BY (print name)

LIMITED EXPRESS WARRANTY

Cummins Inc., hereby warrants Cummins REBUILT EXCHANGE ENGINES, REBUILT EXCHANGE COMPONENTS, OR SERVICE WORK to be free from defects in material and workmanship under normal maintenance and service which are discovered and repaired by Cummins within the period of time, miles, or hours, whichever shall first occur after delivery to the Buyer (Owner), or upon completion of SERVICE WORK and upon conditions hereafter set forth. Cummins's liability shall be limited to repairing or, at its option, replacing any Cummins's rebuilt exchange engines and rebuilt components which satisfaction was defective in material or workmanship and that it is returned with transportation charges prepaid, to Cummins, or an authorized distributor or Dealer of Cummins Inc., within the warranty period as hereinafter set forth. Authorization by Cummins is required prior to such repair being performed and no other express warranty is given. No agent, employee or representative of Cummins is authorized to bind Cummins for any such other warranty. Owner is responsible for all labor charges incurred for removing and reinstalling the engines or assemblies when that becomes necessary to effectuate the particular repair or replacement. Cummins may elect the option, at its sole discretion, to assume the cost of said labor. This warranty coverage is limited to only those parts that are listed on invoice that were used to perform repair. Unless the Owner shall issue specific instructions to the contrary, Cummins will only replace the parts considered necessary for continued operation at a minimum cost to the Owner. Any castings, forgings, or other original parts reused in the repair or rebuilding of an assembly or engine are not covered by this warranty.

WARRANTY WORK coverage is limited to only work done in any Cummins repair facility or by an authorized Cummins employee and provides reasonable labor at a Cummins facility to repair or, at the sole discretion of Cummins's replacement of failed engine components or parts caused by Cummins faulty workmanship.

This warranty shall not apply with respect to any claimed defect which in Cummins's sole judgement has arisen from repair or alteration by anyone other than Cummins, or from accident, negligence or misuse, including, but not limited to, the following: Operation at a speed exceeding rated speed or loading beyond the rated load capacity; operation without adequate coolant, fuel or lubricants; lack of maintenance of cooling, lubricating or air intake systems; improper warm-up, run-in or shutdown practices; lack of normal maintenance services such as engine tune-up and repair or replacement of filters, belts; or overfueling.

Owner is responsible for all costs of oil, fuel, grease, fluids, anti-freeze, fuses, bulbs, filter elements, hoses, belts and other maintenance items replaced during repair.

Cummins shall not be liable for any loss of time to the Owner while the engine assembly or other equipment is out of commission. Nor shall Cummins be liable for any commercial losses or costs of any kind, including, but not limited to, "down time" expenses, towing charges, cargo damage, communication expenses, meals, lodging and other incidental costs incurred by Owner or employees of Owner.

II. USED PARTS LIMITED EXPRESS WARRANTY

Cummins hereby warrants to its original Buyer (Owner) its used parts to be free from defects in material and workmanship under normal use, maintenance and service, which are discovered and reported to Cummins within thirty (30) days after date of invoice to the Owner. Cummins's total responsibility hereunder shall be limited to replacing the defective part with another used part or, at Cummins's election, the amount paid by the Owner for the part will be refunded.

III. NON-CUMMINS PARTS, COMPONENTS AND ASSEMBLIES

Understood by the Owner that Cummins may be furnishing parts, components and assemblies that are obtained from and manufactured by entities other than Cummins including, but not limited to, Cummins Inc. and Diesel ReCon Co. Cummins offers NO express or implied warranties, including the WARRANTY OF MERCHANTABILITY AND FITNESS FOR A PARTICULAR PURPOSE, covering components, parts or accessories manufactured by someone other than Cummins. Such warranties as may be furnished to Cummins or the Owner by the manufacturer of such items will be extended to the Owner and administered by Cummins to the extent allowed by the manufacturer.

IV. WARRANTY STATEMENT DISCLAIMER AND LIMITATIONS OF LIABILITY

THE RESPECTIVE REMEDIES HEREINBEFORE SET FORTH IN THE APPLICABLE EXPRESS WARRANTY SHALL BE THE EXCLUSIVE AND SOLE REMEDIES OF THE OWNER. THERE IS NO IMPLIED WARRANTIES THAT THE EQUIPMENT, COMPONENT PARTS OF ENGINES COVERED BY THIS EXPRESS WARRANTY ARE OF MERCHANTABILITY QUALITY OR THAT THEY ARE FIT FOR ANY PARTICULAR PURPOSE.

CUMMINS DISCLAIMS LIABILITY FOR ANY AND ALL CLAIMS, LOSSES AND DAMAGES TO OWNER RESULTING FROM ANY CAUSE WHATSOEVER (INCLUDING LIABILITY FOR NEGLIGENCE AND STRICT LIABILITY) WITH RESPECT TO ALLEGED DAMAGED OR DEFECTIVE PARTS, DAMAGED OR DEFECTIVE ENGINES AND IMPROPER SERVICING, REGARDLESS OF WHETHER SUCH CLAIMS ARE DISCOVERABLE OR LATENT, SHALL IN NO EVENT EXCEED THE PURCHASE PRICE OF THE PARTICULAR PARTS OR SERVICES WITH RESPECT TO WHICH SUCH CLAIMS OR DAMAGES ARE CLAIMED, OR, AT THE ELECTION OF CUMMINS, THE REPAIR OR REPLACEMENT OF DEFECTIVE OR DAMAGED PARTS OR ENGINES IN NO EVENT, INCLUDING THE COST OF A CLAIM OF NEGLIGENCE OR STRICT LIABILITY SHALL CUMMINS BE LIABLE FOR ANY SPECIAL, INCIDENTAL OR CONSEQUENTIAL DAMAGES, EVEN IF CUMMINS SHALL HAVE BEEN ADVISED OF THE POSSIBILITY OF SUCH POTENTIAL LOSS OR DAMAGE.

TERMS: 100% CORE CREDIT WHEN CORE IS RETURNED WITHIN 45 DAYS OF PURCHASE. 95% CORE CREDIT WHEN CORE IS RETURNED WITHIN 46-90 DAYS OF PURCHASE. NO CORE CREDIT AFTER 90 DAYS OF PURCHASE.

FOLLOWING SCHEDULES APPLY TO:

	Miles	Hours	Months	Material	Labor
Rebuilt Exchange Engines	0-25,000	0-900	0-3	100%	100%
Rebuilt Exchange Components	0-25,000	0-900	0-3	100%	100%
Service Work	0-25,000	0-900	0-3	0	100%
Rebuilt Parts	Not Applicable	Not Applicable	30 days	See Above	0

Warranty coverage is based on miles, hours, or time, whichever first occurs.

CUSTOMER SERVICE CENTERS

NAME OFFICE	1680 N.E. 51st Ave. P.O.Box B Des Moines, IA 50316 (515) 262-9591 Fax (515) 262-0626	625 33rd Ave. S.W. 625 33rd Ave SW Cedar Rapids, IA 52404 (319) 366-7537 Fax (319) 366-7562	701 E. 54th St. No. Sioux Falls, SD 57104 (605) 336-1715 Fax (605) 336-1748	515 Central Ave. P.O. Box 1326 Kearney, NE 68848 (308) 234-1994 Fax (308) 234-5776	7820 42nd St. W. P.O.Box 4445 Rock Island, IL 61204 (309) 787-4300 Fax (309) 787-4397	Integration Center 2402 SE Hulsizer Dr Ankeny, IA 50021 (515) 264-1650 Fax (515) 264-1651
8201 NE Parvin Road Kansas City, MO 64161 (816) 414-8200 Fax (816) 414-8299	3637 East Kearney Springfield, MO 65803 (417) 862-0777 Fax (417) 862-4429	1285 Acraway Garden City, KS 67846 (620) 275-2277 Fax (620) 275-2533	4915 E. 32nd P.O. Box 4675 Joplin, MO 64804 (417) 623-1661 Fax (417) 623-1817	1880 South Range Colby, KS 67701 (785) 462-3945 Fax (785) 462-3970	5101 North Broadway Wichita, KS 67219 (316) 838-0875 Fax (316) 838-0704	

Important information about Cummins engines:

Using this engine for any purpose other than for its intended application provided on the engine's dataplate may be a violation of federal law subject to civil penalty. This engine cannot be installed in new vehicle or equipment. The ReCon engine to be installed is to be of the same or newer model year as the model year of the engine, or engine with aftertreatment system, it is replacing, or if this is unknown, the model year of the engine or equipment in which it is to be used.



MMS Consultants, Inc.
Experts in Planning and Development Since 1975

1917 S. Gilbert Street
Iowa City, Iowa 52240

319.351.8282

mmsconsultants.net
mms@mmsconsultants.net

Environmental Specialists

Landscape Architects

Land Planners

Land Surveyors

Civil Engineers

August 7, 2017

Allen Schneider, Mayor
Riverside City Council Members
Lory Young, City Clerk
City of Riverside
PO Box 188
Riverside, Iowa 52327

RE: Pioneer Project including Alley Vacation West of Murphy's Bar

Honorable Mayor Schneider, Riverside City Council Members and Lory Young:

I am writing this letter at your request concerning the Pioneer Project including the alley west of Murphy's Bar where the alley approaches Highway #22.

During the last year we have had various discussions concerning the south one-half of the north-south alley adjacent to and west of Murphy's Bar and Grill. It has been my recommendation to vacate this portion of the north-south alley for the following reasons:

1. Safety – This alley has been in existence since Riverside has been platted as a town. The visibility for motorists travelling south onto Iowa Highway #22 is impaired. Highway #22 veers northeasterly east of this alley in Riverside. The south bound motorist leaving the alley has a difficult time seeing both to the east and west due to the angle in the road to the east as well as traversing between parked cars on the north side of Iowa Highway #22. The speed limit of Iowa Highway #22 in this area is 25 MPH.
2. Reconstruction of the raised sidewalks between Greene Street and Glasgow Street – The alley slopes from north to south as it enters Highway #22. The steepness of the alley combined with complying with the Americans With Disabilities Act (ADA) makes it more difficult to design and construct this alley, Highway #22 and the elevated sidewalk. The elimination of the alley then allows for the elevated sidewalk to be constructed straight through on the north side of Iowa Highway #22. The elevated sidewalk then would not require two ADA Ramps.
3. Costs – The City of Riverside can save approximately \$81,340.00 by not constructing two ramps, one on each side of the alley. These costs were based on the contract price of the Washburn/2nd Street Project where the cost of a lineal foot of wall was \$1,162.00. We have determined we would eliminate 70 feet of wall. Therefore, 70 feet of wall times \$1,162.00/lineal foot of wall equals = \$81,340.00.



MMS Consultants, Inc.
Experts in Planning and Development Since 1975

1917 S. Gilbert Street
Iowa City, Iowa 52240

319.351.8282

mmsconsultants.net
mms@mmsconsultants.net

Environmental Specialists

Landscape Architects

Land Planners

Land Surveyors

Civil Engineers

During our most recent work session on June 15, 2017 we looked at various alternatives to find better alley access in this particular block in Riverside. Those alternatives are as follows:

1. Establish and construct an east-west alley from Washburn Street to Greene Street.
2. Improve the current alley from Washburn Street to 2nd Street by doing one of the following:
 - A. Purchase the garage from Greg Sojka and cut the corner and remove the power pole.
 - B. Purchase the garage from Laura Temple (or new owner once sold) and round the corner and avoid the power pole by Greg Sojka.
 - C. Move the east-west alley to the south and attempt to align with the alley to the north toward 2nd Street.

We should continue our discussion of this subject so that we can proceed with the most cost effective plan, the safest plan and the best plan that benefits the citizens of Riverside.

Respectfully submitted,

Glen D. Meisner, PE & PLS

T:\2245\2245-013-\2245013L1.docx

WASHINGTON COUNTY ASSESSOR

Hosted by
Vanguard Appraisals, Inc.

Parcel Number: 04-18-237-018
Deed Holder: PICKERING, JAMES N. & CECILIA G.
Property Address: 99 RI 1ST ST E
 RIVERSIDE [MAP THIS ADDRESS](#)
Class: COMMERCIAL
Map Area: RIVERSIDE COM
Plat Map: 4-18G
Sec-Twp-Rng: --
Lot-Block: -
Legal Description: 14 19 OP LOT A & E1/2
Property Report: [PROPERTY REPORT \(PDF FILE\)](#)



1 / 1



Current Value Information			
Land Value	Dwelling Value	Improvement Value	Total Value
\$26,000	\$0	\$85,600	\$111,600

Land Front Foot Information				
Lot	Front	Rear	Side 1	Side 2
Main Lot	50.00	50.00	110.00	95.00
Sub Lot 2	15.00	15.00	22.00	22.00

Agricultural Land Information		
Total Acres	Total CSR	Average CSR
0.0000	0.00	0.00

Commercial Building Information		
Occupancy	Year Built	Building Area
Warehouse	1912	3,973
Metal Retail Store - Steel Frame	1998	1,430

Sale Information			
Sale Date	Amount	Non-Useable Transaction Code	Recording
01/01/1997	\$45,000	50 - Other with explanation	239-65

Sketch

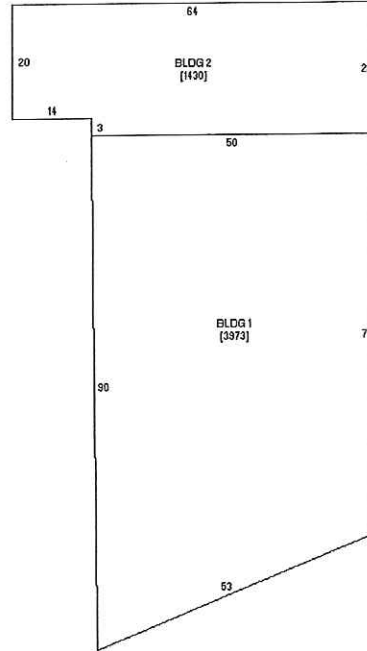

1 / 1

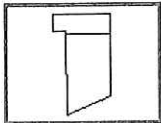

GIS Map Information

Map Changed. Center latitude: 41.3370 ° North. Center longitude: 91.7146 ° West. Scale: one to 288,895.2771. Visible Features: None.

Full Extent Previous Extent Layers Export Print Share Map Query Swipe Select Line Measure Point Markup

Street View Client Info Help Workflow (1)

Parcel
0418237018

Search



Map Title
Web Print 08/17/2017



This map is a user generated static output from an Internet mapping site and is for reference only. Data layers that appear on this map may or may not be accurate, current, or otherwise reliable.

Legend	
	Condo Name Carto 100
	Corp Name Carto 100
	Lot Dim Carto 100
	Lot Dim Carto 400
	Misc Dim Carto 100
	Misc Dim Carto 400
	Misc Text Carto 100
	Misc Text Carto 400
	Mon Carto
	Parcel Dim Carto 100
	Parcel Dim Carto 400
	Parcel Owner Hook 100
	Parcel Owner Hook 400
	Railroad Dim Carto 100
	Railroad Dim Carto 400
	Road Dim Carto 100
	Road Dim Carto 400
	Road Name Carto 100
	Road Name Carto 400
	Sub Ref Letter Carto 100
	Sub Ref Letter Carto 400
	Unknown Carto
Coincident Boundaries	
	Corp Line
	County Line
	Geo Twp Line
	Lot Line
	Misc Line
	Mon Linear
	Page Match Line
	Parcel Line
	Pol Twp Line
	Railroad Centerline
	Railroad ROW

RESOLUTION 07212014-1 ADOPTING THE CITY OF RIVERSIDE COMPHREHENSIVE PLAN

WHEREAS, the City of Riverside did employ an independent firm to develop a comprehensive plan to help guide City leaders and the Community into the future.

WHEREAS, a public hearing on this matter was conducted at 7:00 pm on July 21, 2014 at the Riverside City Hall to obtain any and all input into the plan.

WHEREAS, the City of Riverside Planning and Zoning Commission has reviewed the plan and are recommending that the Council **adopt the plan and use it in decision making in the future.**

IT WAS MOVED BY Kirkwood SECONDED BY Schnoebelen to formally **adopt the Comprehensive Plan and utilize as a tool in decision making.**

Roll Call Kirkwood, Sexton, Kasdorf, Schnoebelen, Schneider

AYES: Kirkwood, Sexton, Schnoebelen, Schneider

NAYS:

Absent/Abstain Kasdorf,

Attest:



Rusty Rogerson, City Administrator/Economic Development



Bill Poch, Mayor



chapter

THREE

Downtown Revitalization

TOP 3
PRIORITY

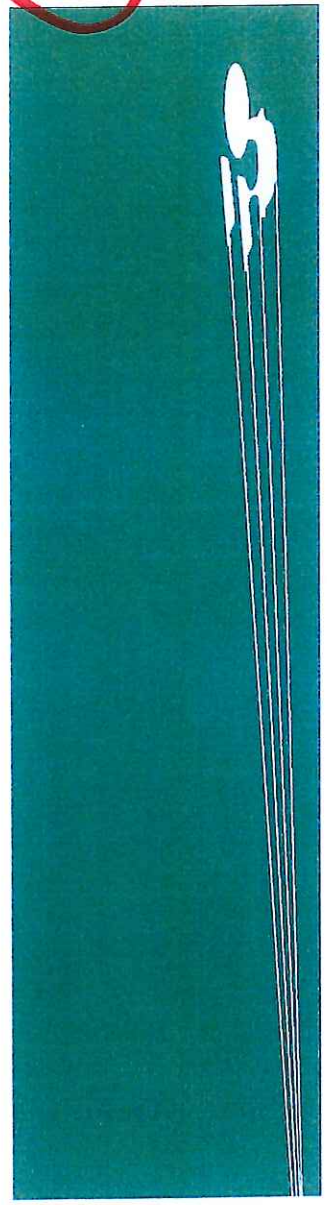

Downtown Today: Issues and Opportunities



HISTORY
Historic buildings line the north side of Highway 22 in downtown Riverside. Several of these are currently under renovation.

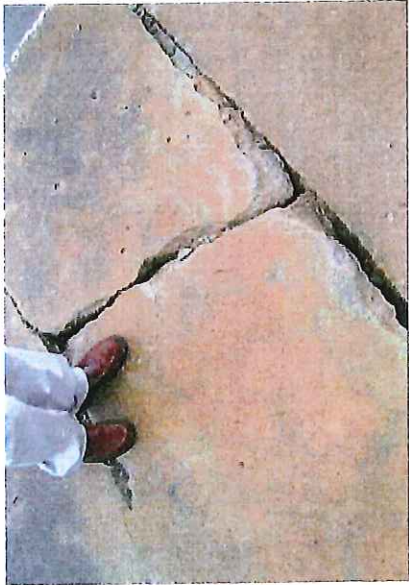

INFRASTRUCTURE
Downtown infrastructure is in poor condition, with visible issues like this cracked sidewalk and less visible issues like the underground stormwater system.



TOURISM
The Star Trek theme provides opportunity to generate tourism and revive interest in downtown, drawing on traffic from nearby attractions like Kalona and the Casino.

SIDEWALK SAFETY
The drop-off of the downtown sidewalk on the north side of Highway 22 poses a significant safety threat and should be addressed immediately.



SUCCESSFUL BUSINESS
Downtown Riverside has several thriving businesses, such as Murphy's Bar and Casa Tequila.

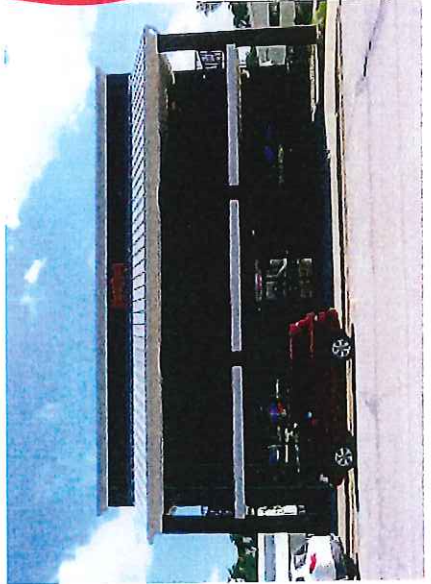

VACANCY
Downtown Riverside has a high percentage of vacant storefronts and buildings that provide opportunity for redevelopment.



Goal: Improve the Highway 22 Streetscape

The 2009 Visioning Plan provided a number of streetscape recommendations. Figure 3.2 shows an updated concept.

1. Incorporate new and preserve existing trees. Street trees can calm traffic, encourage retail sales and create a comfortable pedestrian environment.
2. Consider adding speed table crosswalks, which could aid in the difficult grade transitions from sidewalk level to street level and offer traffic calming.
3. Continue to incorporate planting beds with and without trees throughout the streetscape corridor to add color to the street and add to the overall character of the downtown.

4. Continue to incorporate decorative lighting fixtures that can display banners and hanging plants. Vertical improvements are proven to add significant value to a downtown, retail environment.

5. Work with the DOT to plan curb bump-outs to calm traffic and provide safe pedestrian crossings.

6. Study the closure of East Railroad Street and reconfiguration of parking. Work with the bank to address any concerns about traffic flow in and out of the bank.

7. Continue to plan for additional landscaping and sidewalks on the east end of downtown to improve the gateway experience for motorists and pedestrians.

8. Incorporate opportunities for temporary and permanent public art - such as sculpture, installations, murals and street furniture - that showcases local artists and highlights Riverside's Star Trek claim-to-fame.

REVISIONS TO 2009 VISIONING PLAN

A. Landscape medians at downtown gateway points would serve to calm traffic, but given potential concerns by the low DOT, cost of the improvement and concerns about farm vehicle movement, the City should consider this a low priority.

B. The 2009 Visioning Plan proposal for angle parking is not preferred because it:

- Directs people towards traffic when exiting car.
- Prevents frequent access to the sidewalk due to the wall and proposed railing condition. Research supports that easy movement from vehicles to the sidewalk and from one side of the street to the other supports a healthy business environment.

Alternative solutions include a parallel parking strategy as illustrated in Figures 3.1 and 3.2, or back-in angled parking.

Figure 3.2 - Downtown Streetscape

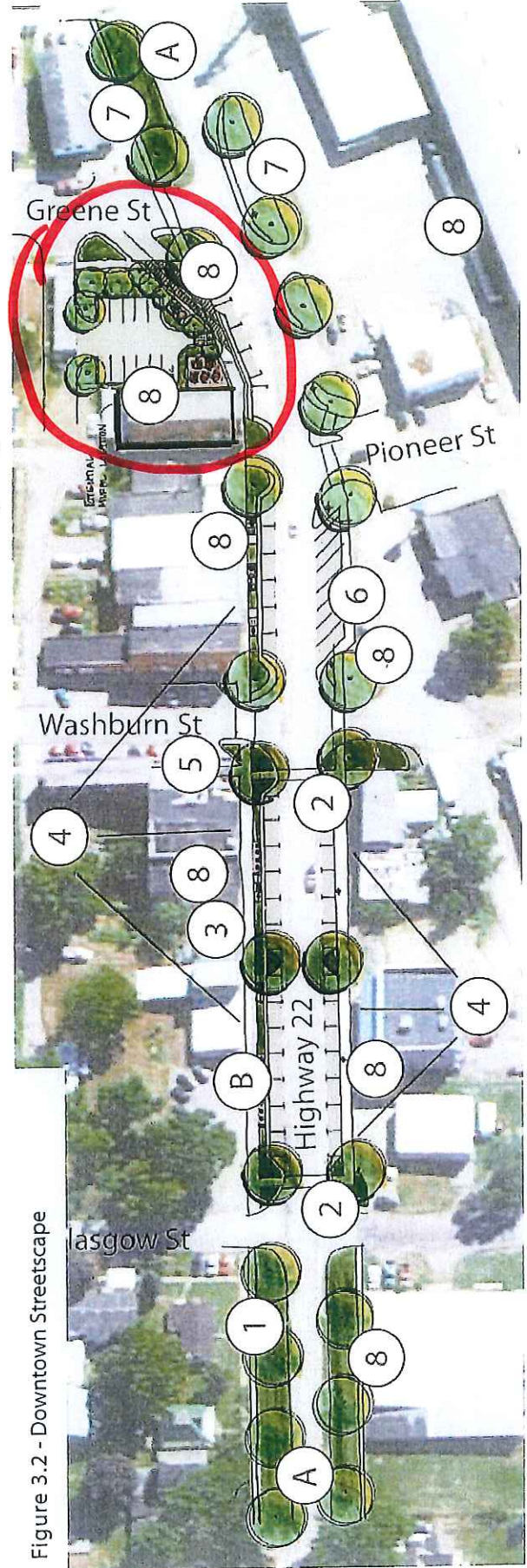

Goal: Explore opportunities for redevelopment on strategic sites

There are several vacant and under-used sites in the downtown, such as those identified in Figure 3.3. Although several of these sites are currently in use, if downtown revitalization is successful, there may be a desire to transition these sites to uses that are more downtown appropriate, such as retail, mixed use, or civic. In some cases the current building could be renovated and re-purposed, while other projects may include demolition.

The city and the proposed Downtown Association (see page 21) should talk with property owners about the possibility of redevelopment or redirection (transition to a new use). The city should consider providing incentives, such as those identified in Chapter 6, to encourage the redevelopment or redirection of these sites as the downtown market improves. Suggested new uses for the sites in Figure 3.3 are listed below the figure.

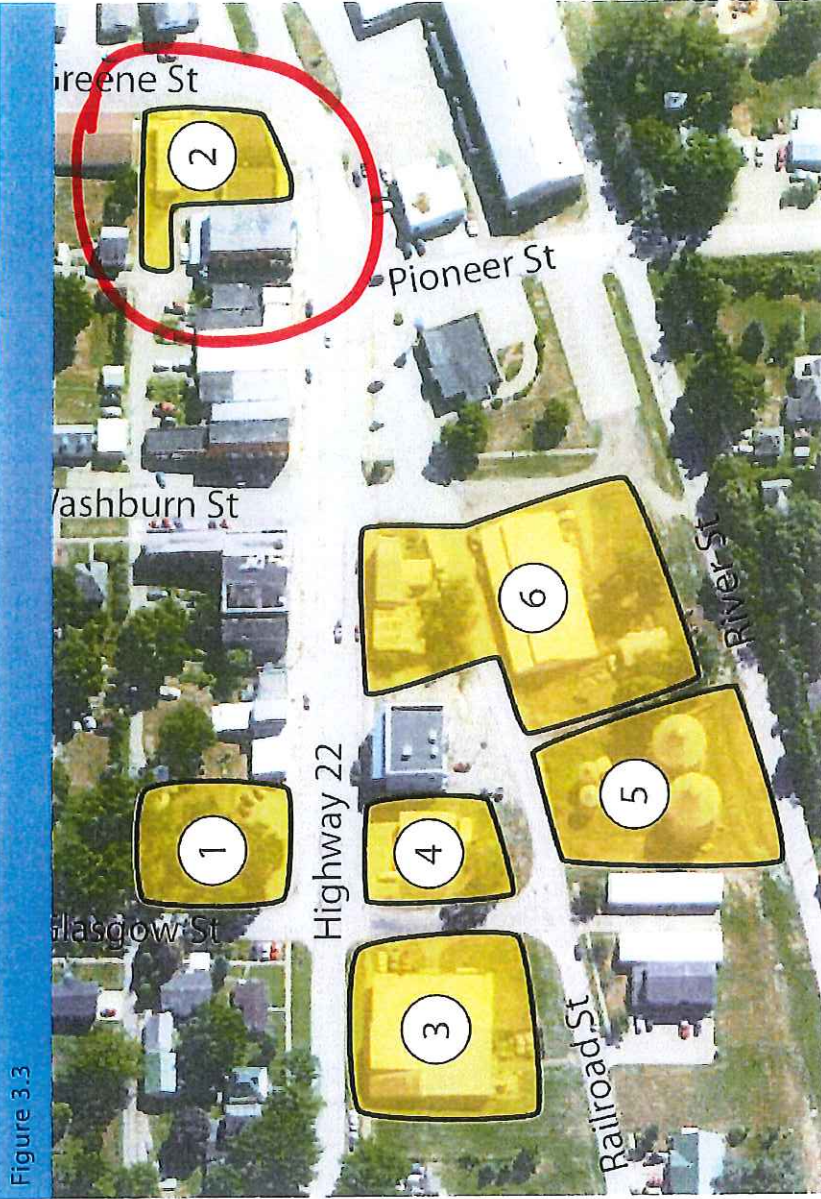
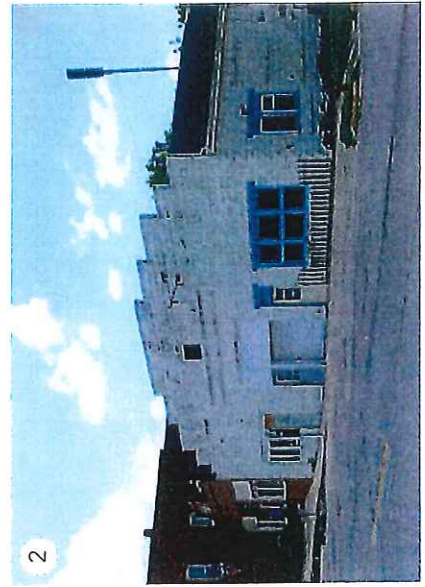
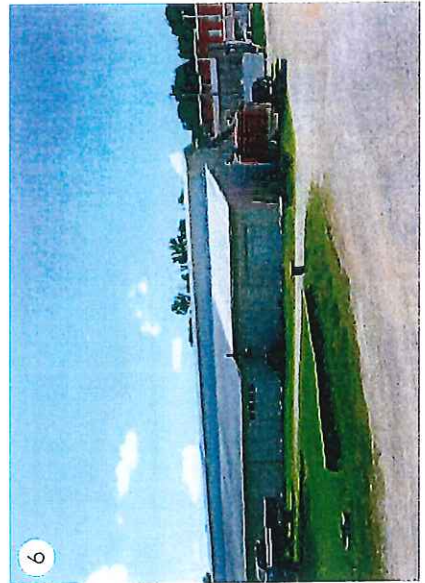
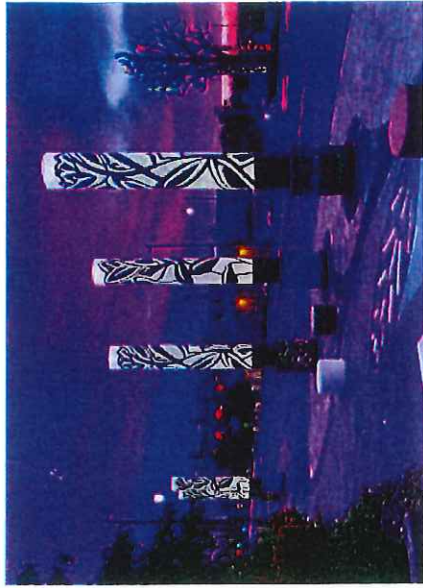

Figure 3.3



- 1 Mixed Use
- 2 Municipal Parking Lot or Mixed Use
- 3 Mixed Use
- 4 Mixed Use
- 5 High Density Residential or Community Center (see Figure 2.3)
- 6 Mixed Use or Community Center (See Figure 2.3)



POSSIBLE EXPANSION ON THE THEME

- Enhance the Riverside History Museum: The museum displays Star Trek memorabilia and collectibles. However, the hours are limited due to a lack of volunteer staff. The collection and the hours should both be expanded.
- Artistic Additions: The theme could be reflected in artistic details such as specialty street paving, lighting, statues, banners, murals, or street furniture.
- Expand TrekFest and/or add other themed events
- Add more "historic" sites: Give visitors more to do around town by establishing additional "historic" sites (e.g. - site of Kirk's first steps, Kirk's favorite place for a cheeseburger, etc.). Museum visitors could receive a map of the sites and an incentive for visiting them all.
- Use branding in city promotional materials and city website.
- Add a gateway feature that builds on the Riverside theme. (See location in graphic at right.)

Riverside's theme could be incorporated into public spaces and streets using planters, street signs, seating, lighting and specialty paving. The photos above show a neighborhood in South Omaha that integrated historical themes from the neighborhood's four ethnic groups into their streetscape.

The proposed municipal parking lot for downtown at the corner of Greene and Highway 22 could serve as an excellent location for an artistic gateway feature and/or a mural on the side of the Murphy's building.

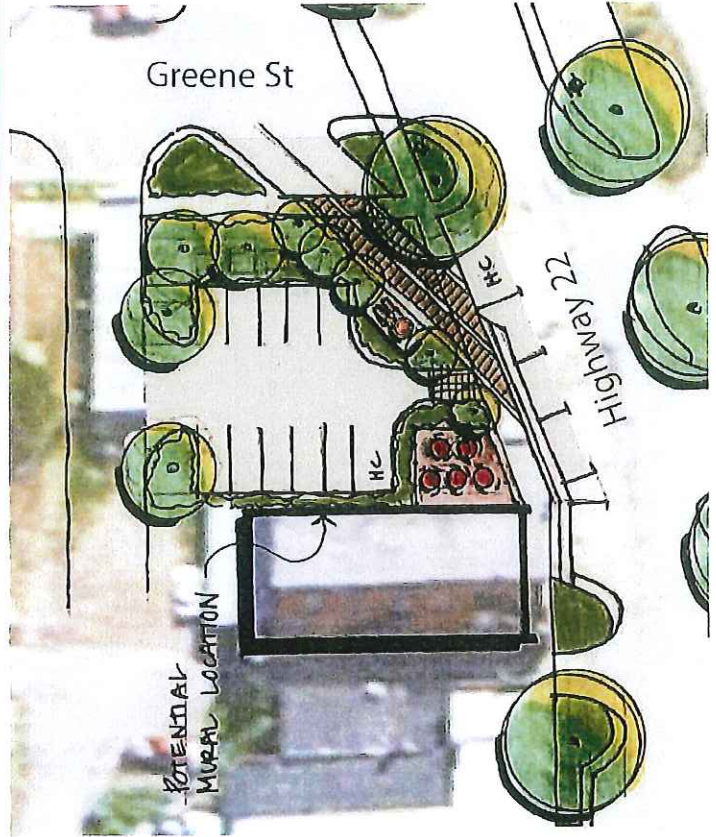

CAUTION ON COPYRIGHT

While Riverside did receive permission from the Star Trek creator to use the slogan of "Future Birthplace of Captain Kirk," copyright law restricts the use of the Star Trek name and associated imagery. The City should confer with an attorney about the use of the theme and discuss their options based on this advice. For example, the City could decide to build on a more generic Science Fiction or space/future theme, to avoid the complexities and restrictions associated with a copyrighted brand.

On H...	Type	ID	Description	Gross	Balance	PO	Check	Pay Date	Post Date	Item Date	Discount ...	Due Date	Unpost ...	Record ...
<input type="checkbox"/>	INV	201307035	RDG PLANNING	\$2,750.00	\$0.00		020100	07/02/2013	07/02/2013	07/03/2013				1
<input type="checkbox"/>	INV	201307205	RDG PLANNING	\$8,308.08	\$0.00		020168	07/16/2013	07/16/2013	07/20/2013				2
<input type="checkbox"/>	INV	201308015	RDG PLANNING	\$5,731.16	\$0.00		020224	08/06/2013	08/06/2013	08/01/2013				3
<input type="checkbox"/>	INV	201309045	RDG PLANNING	\$16,500.00	\$0.00		020321	09/04/2013	09/04/2013	09/04/2013				4
<input type="checkbox"/>	INV	201310085	RDG PLANNING	\$6,054.17	\$0.00		020430	10/10/2013	10/10/2013	10/08/2013				5
<input type="checkbox"/>	INV	201311215	RDG PLANNING	\$5,213.95	\$0.00		020572	11/21/2013	11/21/2013	11/21/2013				6
<input type="checkbox"/>	INV	201312045	RDG PLANNING	\$2,750.00	\$0.00		020630	12/02/2013	12/02/2013	12/04/2013				7
<input type="checkbox"/>	INV	201312265	RDG PLANNING	\$6,054.17	\$0.00		020675	12/26/2013	12/26/2013	12/26/2013				8
<input type="checkbox"/>	INV	201402045	RDG PLANNING	\$2,860.42	\$0.00		020800	02/04/2014	02/04/2014	02/04/2014				9

Total: \$56,221.95
For Comp Plan

RESOLUTION #082117-02

RESOLUTION TO MAKE JAY STUELKE FULL-TIME EMPLOYEE

THEREFORE BE IT RESOLVED, the City of Riverside City Council would like to change Jay Stuelke's employee status to regular full-time employee at the wage rate of \$18.35 per hour to be paid bi-weekly with the other regular employees, effective for the pay period beginning 08-20-17.

It was moved by Councilperson _____, seconded by Councilperson _____ to adopt this foregoing resolution.

Roll Call: Schneider, Redlinger, Sexton, Weber, Schnoebelen

Ayes:

Nays:

Absent:

PASSED AND APPROVED by City Council of Riverside, Iowa, on this 21st day of August, 2017.

Signed: _____
Allen Schneider, Mayor

Attest: _____
Lory Young, City Clerk

Monthly Premiums:	08/17/2017
Helath Insurance	\$1,663.39
Denatal Insurance	\$33.27
Life & A D & D	\$24.02
IPERS	8.93%
FICA	6.20%

Providing world class technology services with a home town touch

iTech Monthly Maintenance Contract

General rules

- 1 hour call response time.
- No limit to included on-site calls or hours, however over phone and remote need to be attempted before on-site happens.
- If new equipment is added it alters the next monthly billing.
- Invoices will be mailed at beginning of month. All invoices are due within 15 days of receipt of invoice.
- Evaluation of current systems for further expansions and upgrades.
- Purchasing of hardware/software is not included in the monthly maintenance plan.
- Installation of software is included in plan but installation of new hardware would be outside the scope of the plan.
- Support of staff or equipment includes the main site only; any additional sites would have to be added to the plan if it is expected for iTech to support the extra sites.
- This contract is for 1 year
- The monthly cost of this is \$205.00

New Equipment rules

- New equipment requiring iTech support will alter next month's bill.
- All new equipment and equipment repair is quoted to the customer.

On-Site

- Currently on-site calls have no limit to quantity or duration.
- If a high volume of on-site calls occur over an extended amount of time, maintenance contract may come up for negotiation.
- All issues need to have remote support attempted before coming on-site. If on-site time is required then a 1 hour response time within 15 miles or 2 hours for locations 16-45 miles from Kalona.
- A monthly on-site visit occurs on scheduled times.
- On-site requires authorization from an approved employee listing.

Remote support

- All devices capable of having remote connections must have this setup.
- Phone support is to be used until it becomes incapable or is considered ineffective time usage.

Violations

- All training of software not directly supported by iTech is billable time.
- Any software not installed or approved by iTech is not supported by this contract.
- If payment is not received by 15th of month then all support will cease until payment is received.

We are not responsible for:

- Any results from violation of contract terms.
- Lost or damaged hardware and software due to customer misuse of equipment.

Please note, all contracts will be reviewed and signed on an annual basis.

By signing below you are accepting the above terms:

Customer _____

Title _____ Date _____

City of Riverside Employee (Cost of Living Adjustment) Raises

DATE	RESOLUTION #	COST OF LIVING %
7/1/2000	060500-2	3%
7/1/2001	030501-1	3%
7/1/2002	06302-2	3%
7/1/2003	071403-1	5%
1/5/2004	010504-2	\$.80 BRAD
7/1/2005	062005-2	2%
7/1/2006	080706-4	3%
7/1/2007	080607-6	4.5%
7/1/2008	070708-4	3%
7/1/2009	070609-2	3% (B. LENZ 2.5%)
7/1/2010	08042010-1	3% (T. THOMAS 6%)
7/1/2011	08052011-12	3%
7/1/2012	07162014-4	3%
7/1/2013	08152013-2	2.4%
7/21/2014	07212014-03	3.15% NO "COLA" RAISE, VOTE 4-0
7/1/2015	NO RESOLUTION	NO "COLA" RAISE
7/5/2016	07052016-04	2%

7/1/2017 Surrounding Cities COST OF LIVING salary increases;

AINSWORTH	0%
HILLS	3%
KALONA	5-7%
LONE TREE	3%
WASHINGTON	3-5%
WELLMAN	3%

		FY 16-17	FY 17-18	FY 16-17	FY 17-18
CITY	POPULATION	TAX RATE	TAX RATE	BUDGET	BUDGET
RIVERSIDE	993	\$8.10	\$8.10	\$5,200,493.00	\$6,315,463.00
HILLS	703	\$8.10	\$8.10	\$4,071,427.00	\$4,272,524.00
LONE TREE	1300	\$9.20	\$9.18	\$2,044,986.00	\$1,954,233.00
WELLMAN	1408	\$12.06	\$11.88	\$4,338,106.00	\$3,511,697.00
KALONA	2363	\$9.57	\$12.39	\$2,793,302.00	\$3,392,724.00

DATE: 7/01/2014 THRU 6/30/2015

REPORT TOTALS

	1ST - QUARTER TOTALS		2ND - QUARTER TOTALS		3RD - QUARTER TOTALS		4TH - QUARTER TOTALS		** TOTAL **	
NBR CHECKS	62 CHECK(S)		54 CHECK(S)		75 CHECK(S)		57 CHECK(S)		248 CHECK(S)	
NET	-	58803.43		48698.80		65010.10		47698.91		220211.24
EARNINGS	HOURS	AMOUNT	HOURS	AMOUNT	HOURS	AMOUNT	HOURS	AMOUNT	HOURS	AMOUNT
GROSS	-	85591.76		70479.85		91893.81		68212.33		316177.75
REGULAR	-	2466.00 52649.73	2275.25	48140.80	2789.75	56495.00	2014.50	42466.17	9545.50	199751.70
SALARY	-	0.00 16699.61	0.00	8135.54	0.00	17616.27	0.00	14522.76	0.00	56974.18
OVERTIME	-	267.25 9023.87	156.88	5199.30	250.75	8386.08	93.00	3149.17	767.88	25758.42
SICK	-	113.00 1966.73	95.75	1802.06	88.00	1416.84	74.75	1485.45	371.50	6671.08
VACATION	-	32.00 398.64	183.00	4430.30	330.14	6038.74	222.50	3664.70	767.64	14532.38
PERSONAL	-	40.00 789.12	31.00	613.56	16.00	368.00	37.00	564.76	124.00	2335.44
BEREAVE	-	0.00 0.00	14.00	272.28	0.00	0.00	0.00	0.00	14.00	272.28
HOLIDAY	-	222.00 3932.20	38.00	786.44	84.00	1572.88	130.00	2359.32	474.00	8650.84
COMP	-	6.00 131.86	52.75	1099.57	0.00	0.00	0.00	0.00	58.75	1231.43
ADVANCE PAY-		0.00 400.00	0.00	300.00	0.00	400.00	0.00	100.00	0.00	1200.00
DEDUCTIONS	EMPLOYER	DEDUCT	EMPLOYER	DEDUCT	EMPLOYER	DEDUCT	EMPLOYER	DEDUCT	EMPLOYER	DEDUCT
FAMILY DENT	1482.60	164.92	1239.06	137.80	1345.20	149.52	1345.20	148.16	5412.06	600.40
FAMILY HEAL-	25037.25	2782.15	20506.68	2278.68	18883.80	1748.50	18883.80	2145.95	83311.53	8955.28
ICMA D COMP-	0.00	0.00	0.00	0.00	0.00	0.00	0.00	0.00	0.00	0.00
IPERS	5980.86	3984.99	5007.39	3336.38	5932.33	3952.65	4643.30	3093.80	21563.88	14367.82
TAXES	TAXABLE	TAX	TAXABLE	TAX	TAXABLE	TAX	TAXABLE	TAX	TAXABLE	TAX
FEDERAL W/H-	78659.70	9197.71	64726.99	7359.01	86043.14	9706.25	62824.42	6881.95	292254.25	33144.92
STATE W/H	78659.70	4015.00	64726.99	3271.00	86043.14	4157.00	62824.42	3162.00	292254.25	14605.00
FICA	81375.03	5045.21	66310.05	4111.26	88142.47	5464.85	64931.56	4025.74	300759.11	18647.06
MEDICARE	82644.69	1198.35	68063.37	986.92	89995.79	1304.94	65918.22	955.82	306622.07	4446.03
EIC CREDIT	-	0.00		0.00		0.00		0.00		0.00

Gross Payroll

DATE: 7/01/2016 THRU 6/30/2017

REPORT TOTALS

	1ST - QUARTER TOTALS		2ND - QUARTER TOTALS		3RD - QUARTER TOTALS		4TH - QUARTER TOTALS		** TOTAL **	
NBR CHECKS	48 CHECK(S)		59 CHECK(S)		46 CHECK(S)		48 CHECK(S)		201 CHECK(S)	
NET	-	27743.26		34379.99		34937.58		28134.99		125195.82
EARNINGS	<u>HOURS</u>	<u>AMOUNT</u>	<u>HOURS</u>	<u>AMOUNT</u>	<u>HOURS</u>	<u>AMOUNT</u>	<u>HOURS</u>	<u>AMOUNT</u>	<u>HOURS</u>	<u>AMOUNT</u>
GROSS	-	38435.04		47171.25		49710.19		38944.88		174261.36
REGULAR	-	1470.25 30523.28	2010.50	40637.78	1856.25	36983.03	1527.75	30551.51	6864.75	138695.60
SALARY	-	0.00 999.99	0.00	1333.32	0.00	666.66	0.00	666.66	0.00	3666.63
OVERTIME	-	56.25 1986.77	55.25	1773.40	77.00	2406.99	77.75	2428.72	266.25	8595.88
SICK	-	71.25 1182.75	83.50	1845.00	91.25	1859.61	33.25	592.88	279.25	5480.24
VACATION	-	78.25 1794.25	45.25	739.75	280.87	6249.40	133.50	2665.91	537.87	11449.31
PERSONAL	-	12.00 180.00	16.00	400.00	28.00	555.56	16.00	271.20	72.00	1406.76
HOLIDAY	-	88.00 1768.00	22.00	442.00	52.00	988.94	88.00	1768.00	250.00	4966.94
DEDUCTIONS	<u>EMPLOYER</u>	<u>DEDUCT</u>	<u>EMPLOYER</u>	<u>DEDUCT</u>	<u>EMPLOYER</u>	<u>DEDUCT</u>	<u>EMPLOYER</u>	<u>DEDUCT</u>	<u>EMPLOYER</u>	<u>DEDUCT</u>
FAMILY DENT	400.08	44.46	400.08	44.46	860.34	95.43	466.70	51.85	2127.20	236.20
FAMILY HEAL-	8153.76	906.00	8762.64	1041.36	12230.64	1359.00	9512.72	1057.00	38659.76	4363.36
IPERS	3166.53	2109.85	3882.94	2587.15	4097.97	2730.45	3161.64	2106.54	14309.08	9533.99
SINGLE DENT-	219.84	9.72	222.56	10.48	89.40	4.80	213.00	9.70	744.80	34.70
SINGLE HEAL-	1721.40	90.60	1849.92	97.38	0.00	0.00	1434.50	75.50	5005.82	263.48
TAXES	<u>TAXABLE</u>	<u>TAX</u>	<u>TAXABLE</u>	<u>TAX</u>	<u>TAXABLE</u>	<u>TAX</u>	<u>TAXABLE</u>	<u>TAX</u>	<u>TAXABLE</u>	<u>TAX</u>
FEDERAL W/H-	35274.41	3175.23	43390.42	3635.12	45520.51	4749.72	35644.29	3198.32	159829.63	14758.39
STATE W/H	-	35274.41	1496.00	43390.42	1858.00	45520.51	2142.00	35644.29	1423.00	159829.63
FICA	-	37384.26	2317.84	45977.57	2850.63	48250.96	2991.55	37750.83	2340.58	169363.62
MEDICARE	-	37384.26	542.08	45977.57	666.68	48250.96	699.66	37750.83	547.40	169363.62
EIC CREDIT	-		0.00	0.00		0.00		0.00		0.00

Gross Payroll

FWI from ICMIA Conf.

Who is Leading Who?

AUGUST 3, 2017

One of the main responsibilities of a leader is to fire their people! Not actually fire them but fire them up.

Fire them up as in motivate them, challenge them, coach them, help them grow and help them succeed, again and again. If you're in a leadership position and you're not doing those things on a daily basis then you are simply not leading.

If you're in a leadership position and you're not actually leading then you're hurting the people you're supposed to be helping. You're also not helping the organization that has placed you into that leadership position and provided you with the opportunity to lead.

Don't make the mistake of assuming that your position makes you a leader. The only thing, the one and only thing that makes you a leader is leading. If you find yourself in a leadership position while lacking the skills required to truly lead then it is YOUR responsibility to seek out the help and training that you need to be a successful leader.

Don't wait for someone else to make you a leader, don't expect the help you need to come to you. If you're going to lead others then you must first lead yourself so lead yourself to the coaching you need to become a true leader.

If you're following someone in a leadership position who lacks the skills to lead then you have three choices.

You could just complain about it. You could point out their failings at every opportunity and become a drag on the entire organization. I've done that and it didn't really work out well for anyone, especially me.

You could, and should, attempt to lead up. By that I mean help fill the gaps of the person who is supposed to be leading you. You've no doubt already identified those gaps so try to use your own strengths to minimize the challenges those gaps cause within your company or organization.

I'll warn you that you may not get the recognition you deserve for leading up. Some people in your organization might even call you a suck up or worse. Even the person who is supposed to be leading you may be a bit leery about your motives but you'll be doing the right thing. I can say with a high degree of certainty that doing the right thing will eventually pay off; it might take longer than you want but you can't go wrong by doing right.

The third option you have is to flee. Just leave, go find employment elsewhere. This is not as good an option as it may seem. While you left a problem behind you have no guarantee that you're not just walking into another one. You also slow your own development by just leaving when the going gets a little tough.

You may get lucky and join an organization that provides you with a true leader who works hard to develop and mentor you. If that's the case then you've truly struck gold. The problem I have is with the luck part; I simply don't like depending on luck for my success.

I think most successful people would tell you that they made their success, they didn't just luck into it.

So I've written a bit here to leaders and the people who would follow them. I also want to say something to a third group. That would be the folks who put people who can't lead into leadership positions.

The truth is most organizations were able to "get away" with that for a long time. There used to be plenty of followers to go around and if an organization lost a few here and there they just plugged in some new people.

Not anymore!

One of the key considerations an organization must make these days is who is leading who. If you have good young talent being led by a non-leader in a leadership position that good young talent will leave. That's not a guess, that's not a maybe, they will be gone, period. And they are getting harder to replace by the day.

Whether you're in Human Relations or another senior position within your organization, if you're responsible for placing people into leadership positions then you better make sure you're putting actual leaders into those positions.

There is almost no bigger waste in business today than giving a bright, motivated potential superstar in your organization to a person in a leadership position who lacks the ability to help that bright, motivated individual achieve success.

There will always be some leaders who are better than others. You need to be certain that your best people are being led by your best leaders. That's the reality of the business world in which we live today; no organization can afford to have their top people led by people who are not leaders.

You may want to consider dealing with it before it's dealt with for you.



August 17, 2017

FYI

City of Riverside
PO Box 188
Riverside, IA 52327

ATTENTION: Honorable Mayor and Council

Notice of Violation: NPDES General Permit #2 Part VI.A.1 Duty to Comply
Part III. Prohibition on Non-Storm Water Discharges
Part IV Storm Water Pollution Prevention Plans

Subject: Storm Water Complaint Investigation; FOCD Complaint #24587
NPDES #30510-30238, City of Riverside 2nd Street and Washburn Street Storm Sewer
and Paving Project, Washington County, Iowa

City Officials:

On August 10, 2017 I investigated a complaint at the site indicated above. The complainant claimed that best management practices (BMPs) were not being properly implemented on the project and sediment was entering the storm drains.

At the time of my complaint investigation, concrete work was taking place and some earthwork appeared to have recently taken place as well. Straw waddles had been installed around a few intakes behind the curb. No curb erosion control had been installed and the street contained piled rock and some soil from the grading/excavating work. A rain event occurred at the time of my investigation. I collected a sample of the storm water from the construction site that was entering the storm water intake on the northwest corner of the 2nd Street and Ella Street intersection. This storm water was very turbid and contained sediment from the construction site. The sample was delivered to the State Hygienic Laboratory in Iowa City and analyzed for turbidity. The result indicated that the sample I collected had Nephelometric turbidity units of 3600.

I contacted Glen Meisner (City of Riverside Engineer with MMS Consultants) via email and he has conveyed that specific action will be taken regarding effective erosion control and permit compliance. My recommendations of intake protection and curb erosion control were also conveyed to the responsible parties. The storm water pollution prevention plan (SWPPP) and inspection reports were requested via email on August 14, 2017. The SWPPP was received August 15, 2017.

A notice of violation is being issued for failure to comply with the requirements set forth in the DNR General Permit # 2 (GP2). The measures outlined in the SWPPP did not appear to be implemented at the time of my investigation. The few BMPs that were implemented on site did not prevent sediment from discharging from the site. The storm water pollution prevention plan (SWPPP) was not effective in properly managing storm water on this permitted site.

The following SWPPP and documentation items were deficient at the time this letter was drafted:

1. The SWPPP sequence of events, item # 3, outlined mulch berms being installed along adjacent property lines. These did not appear to be implemented.
2. The SWPPP sequence of events, item # 4, outlined the installation of silt blocking devices at adjacent street storm intakes. These controls did not appear to be implemented at all intakes.
3. Section 2.1 of the SWPPP, Erosion and Sediment Control, states that prior to any soil disturbing activities occurring on site, downslope silt fence will be installed. Storm inlet protection was to be conducted at this same time. This did not appear to be implemented properly.
4. The site erosion control calls for silt fence and inlet protection installed at specific locations and all measures did not appear to be installed.
5. Inspections reports had not been received at the time this letter was drafted.

The SWPPP received was a copy from the engineer. Be advised that the owner and the contractor certifications outlined in the SWPPP must be signed in the on-site or official copy. In addition, be advised that general water criteria, outlined in 567 IAC 61.3(2), states, "The following criteria are applicable to all surface waters including general use and designated use waters:

61.3(2)f. The turbidity of the receiving water shall not be increased by more than 25 NTUs by any point source discharge.

Effective erosion controls must be implemented immediately. Be reminded that the measures outlined in the SWPPP must be implemented or the SWPPP must be updated to reflect installation of effective measures. I will conduct a follow up visit to assess compliance. If you have any questions, need assistance, or would like further explanation of any part of this letter, please contact me in this office at 319-653-2135 or at brian.lee@dnr.iowa.gov.

Sincerely,
FIELD SERVICES & COMPLIANCE BUREAU



Brian Lee
Environmental Specialist

N:FO6\BLEE\Stormwater\Riverside streets NOV 081117
N:FO6\PICTURES\2017\August\Harrison stw 052417 (1-15)

xc: Storm Water Section, DNR, Des Moines
Glen Meisner and Dave Schmidt Construction via email
Washington County stw complaint file
Complainant