

**CITY OF RIVERSIDE COUNCIL AGENDA
RIVERSIDE CITY HALL COUNCIL CHAMBERS
60 N GREENE STREET**

Monday, November 7th, 2016 at 6:30 p.m.

6:30 PM – Regular City Council Meeting

NOTICE TO THE PUBLIC:

This is a meeting of the City Council to conduct the regular business of the City. Every item on the agenda is an item of discussion and action if needed.

CALL MEETING TO ORDER: Mayor Schneider

- Pledge of Allegiance
- Roll Call

APPROVAL OF AGENDA:

1. Approve Consent Agenda

- 1a) Minutes from 10-17-16
- 1b) Expenditures 11-07-16
- 1c) Liquor License – Casey's

2. Committee Reports:

3. Citizens Comments:

This time is for items NOT on the agenda. Please notify the City Clerk if you wish to comment on an agenda item and you will be recognized when that item comes up. When citizens are recognized to speak, please approach the podium, spell your first and last name before proceeding. Citizens should refrain from addressing individual Council Members and should not expect a response to any questions. Time is limited to 3 minutes.

4. Res #11072016-01 "Kalona News as Official Publication" pg 10

5. MMS Consultants Update: (Some items may need action)

- 5a) Cherry Lane Subdivision
 - o Liquidation Damages on Contract – Matt Bockenstedt of Rathje Construction
 - o Utilities – Tom Sexton
- 5b) Ella Street
- 5c) Casey's Sewer Project

6. Res #11072016-02 "Change Order #7 Cornerstone – Ella Street - Sodding" pg 12

7. Res #11072016-03 "Change Order #8 Cornerstone – Ella – Beehive & Intake" pg 14

8. Res #11072016-04 "Change Order #9 Cornerstone - Granular Surfacing Material" pg. 18
9. Res #11072016-05 "Pay Request #6 Cornerstone – Ella Street Project" pg. 20
10. Closed Session pursuant to Iowa Code Section 21.5(1)(j) – Real Estate
 - Vote to go into Closed Session
 - Vote to come out of Closed Session & return to Open Meeting
11. Motion to proceed as directed in Closed Session
12. PeopleService Information (may need a motion for action)
 - Lift Station Cleaning, Pump and Control Inspection
 - Wastewater SBR System Check
 - Locator
 - Fixed Base water meter system
13. Resolution #11072016-05 "Building Permit Fee Schedule" pg 48
14. ARAMARK Contract pg 72
15. Streets and Parks
 - Bid to repair sink holes
 - Visibility at intersections
 - Part-time Employee search
 - Snow Removal Equipment
16. Employee Compensation
 - * Closed Session upon Employee Request pursuant to Iowa Code Sec. 21.5(1)(i)
17. Elder Services – Continuing Meals pg 95
18. Closing Comments
 - City Staff Comments
 - City Council Comments & Requests for Information
19. Adjourn Council Meeting

Approved: _____
Allen Schneider, Mayor

Date: _____

RIVERSIDE CITY COUNCIL MEETING; OCTOBER 17, 2016

The Riverside City Council meeting opened at 6:31 pm in City Hall with Mayor Allen Schneider requesting roll call. Council members present were: Ralph Schnoebelen, Jeanine Redlinger, Bob Schneider Jr., Tom Sexton, and Rob Weber.

Motion by Schnoebelen to approve agenda. Second by Redlinger, passed 5-0.

Motion by Sexton to approve consent agenda, minutes, and expenditures. Second by Schnoebelen, passed 5-0.

Citizens Comments; Kathy Lindhorst reminded council of RACC Haunted Trail Ride on Saturday, October 22 beginning at 7 pm from the Community Building. Larry Simon discussed blind intersections in town. Council will have Lenz check out, and form a list. Homeowners will be notified to trim back vegetation.

Council voted to pass the third reading of Zoning Ordinance, 5-0. Ordinance will be adopted at date of official publication.

Mayor Schneider opened Public Hearing for sale of city property to Doug Havel at 6:45 pm. There were no written or oral comments from the public. Public Hearing closed at 6:47pm. Schnoebelen moved to pass Resolution #10172016-01 Sell property to Doug Havel for \$37,302.91. Second by Schneider, passed 5-0.

Glen Meisner, MMS Consultants gave engineering updates on Capital Projects.

Schnoebelen moved to proceed with lifting concrete around manhole at 199 Schnoebelen Street with mud jacking. Second by Weber, passed 5-0.

Ella Street final coat of asphalt will start next Tuesday. Council discussed Ella Street concerns. Sexton moved to replace four sections of sidewalk at the south end of 311 N. Ella, raising 5" at the lowest point. Second by Weber, passed 5-0.

Schneider moved to fill in ruts on West 4th Street with asphalt while company is here. Second by Weber, passed 5-0.

Schneider moved to sod the Ella Street City right of way, excluding the \$2500 re-grading fee, for an estimated cost of \$19,166.40. Second by Weber, passed 5-0.

Schnoebelen moved to pass Resolution #10172016-02 Change Order #4 to Rathje Construction, lawn seeding on Cherry Lane, for \$2031.24. Second by Weber, passed 5-0.

Sexton moved to pass Resolution #10172016-03 Pay Estimate #5 to Rathje Construction, Cherry Lane, for \$10,501.34. Second by Weber, Passed 5-0.

Schneider moved to table Resolution # 10172016-04 Building Permit Fees, to gather information on what surrounding Cities are charging. Second by Sexton, passed 5-0.

Schnoebelen moved to pass Resolution #10172016-05 Waive the right to review Pigg Hills Flats plat. Second by Schneider, passed 5-0.

Schnoebelen moved to Release Letter to Insurance for 51 S. Boise Street. Second by Weber, passed 5-0.

Sexton motioned to move Becky LaRoche to full time status for working over 30 hours per week, qualifying for insurance benefits. Second by Schnoebelen, passed 5-0.

Schneider moved to allow Lory Young to carry over 64 hours of vacation to be used by December 31, 2016, and to reset all employee vacation to calendar year on January 1, 2017. Second by Weber, passed 4-1, Sexton opposed.

Council agreed to advertise for part time seasonal help for streets and parks.

Weber moved to un-suspend farming agreement with John Roetlin for city owned ground north of Cherry Lane. Second by Sexton, passed 5-0.

Redlinger moved to adjourn at 9:23 pm. Second by Weber, passed 5-0.

Full content of Council Meetings can be viewed on the City Web Site;
www.cityofriversideiowa.com

Council Work Session on employee handbook – Thursday, October 27, 2016 at 6:30 pm.
NEXT CITY COUNCIL MEETING – Monday, November 7, 2016 at 6:30 pm.

ATTEST:

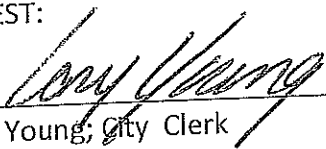

Lory Young; City Clerk



Allen Schneider; Mayor

SEPT. 2016 REVENUES & EXPENSES:		REVENUES	EXPENSES
		\$ 53,100.67	\$ 35,294.19
GENERAL FUND		\$ 12,806.20	0
ROAD USE TAX FUND		\$ 8,361.89	0
LOCAL OPTION SALES TAX		\$ 76,910.45	\$ 1,257.00
CASINO REVENUE FUND		\$ 67,974.10	\$ 291,462.49
CAPITAL PROJECTS FUND		\$ 39,450.16	15460.69
WATER FUND		\$ 36,103.20	13862.82
SEWER FUND		\$ 2,016.16	1719.5
GARBAGE/LANDFILL FUND		\$ 1,566.62	0
STORM WATER FUND			
		\$ 298,289.45	\$ 359,056.69
TOTAL			

11/02/2016 10:03 AM
 PACKET: 02881 EXPENDITURES 11-7-16 BL
 VENDOR SET: 01 City of Riverside
 SEQUENCE : ALPHABETIC
 DUE TO/FROM ACCOUNTS SUPPRESSED

Council Packet

A/P Direct Item Register

-----ID-----	ITM DATE BANK CODE	-----DESCRIPTION-----	GROSS DISCOUNT	P.O. # G/L ACCOUNT	---ACCOUNT NAME---	DISTRIBUTION	
** G/L ACCOUNT TOTALS **							
BANK YEAR	ACCOUNT	NAME	AMOUNT	ANNUAL BUDGET	BUDGET OVER AVAILABLE BUDG	ANNUAL BUDGET	BUDGET OVER AVAILABLE BUDG
	600-5-810-6140	UNEMPLOYMENT EXPENSE	670.50	0	670.50- Y	394,712	318,808.71
	600-5-810-6324	TOWER MAINTENANCE	5,653.00	6,000	347.00	394,712	313,826.21
	600-5-810-6371	ELECTRIC AND GAS	97.73	32,000	21,864.78	394,712	319,381.48
	600-5-810-6407	ENGINEERING EXPENSE	148.50	5,000	4,416.64	394,712	319,330.71
	600-5-810-6504	REPLACEMENT ITEMS	100.00	5,000	4,502.00	394,712	319,379.21
	600-5-810-6507	OPERATING EXPENSES & SUP	17.10	7,000	6,447.79	394,712	319,462.11
	610-2020	ACCOUNTS PAYABLE	2,390.79-*				
	610-5-815-6140	UNEMPLOYMENT EXPENSE	670.50	0	670.50- Y	284,696	216,595.45
	610-5-815-6330	GENERATOR REPAIR & MAINT	1,068.00	10,000	7,864.00	284,696	216,197.95
	610-5-815-6371	ELECTRIC & GAS	589.19	60,000	43,977.64	284,696	216,676.76
	610-5-815-6507	OPERATING EXPENSES	17.10	6,000	5,650.80	284,696	217,248.85
	610-5-815-6510	UPS - SEWER	46.00	500	247.87	284,696	217,219.95
	670-2020	ACCOUNTS PAYABLE	600.00-*				
	670-5-840-6372	GARBAGE STICKERS	600.00	1,200	600.00	24,700	15,437.30
	999-1330	DUE FROM OTHER FUNDS	34,373.76 *				

** 2016-2017 YEAR TOTALS 34,373.76 ✓ w/ Exp. be

TOTAL ERRORS: 0 TOTAL WARNINGS: 0

** END OF REPORT **

Council Packet

11/3/2016

CITY OF RIVERSIDE
 MTD TREASURERS REPORT
 AS OF: SEPTEMBER 30TH, 2016

	BEGINNING CASH BALANCE	M-T-D REVENUES	M-T-D EXPENSES	CASH BASIS BALANCE	NET CHANGE OTHER ASSETS	NET CHANGE LIABILITIES	ACCUAL ENDING CASH BALANCE
GENERAL FUND	1,580,291.02	53,100.67	35,294.19	1,598,097.50	357.30 (338.48)	1,597,401.72
ROAD USE TAX	353,688.44	12,806.20	0.00	366,494.64	0.00	0.00	366,494.64
LOCAL OPTION SALES TAX	250,472.68	8,361.89	0.00	258,834.57	0.00	0.00	258,834.57
TIF	0.00	0.00	0.00	0.00	0.00	0.00	0.00
CASINO REVENUE FUND	1,020,920.49	76,910.45	1,257.00	1,096,573.94	0.00	0.00	1,096,573.94
DEBT SERVICE	0.00	0.00	0.00	0.00	0.00	0.00	0.00
CAPITAL PROJECTS	333,603.34	67,974.10	291,462.49	110,114.95	0.00	0.00	110,114.95
WATER FUND	711,863.71	39,450.16	15,460.69	735,853.18	0.00 (382.51)	735,470.67
SEWER FUND	161,621.08	36,103.20	13,862.82	183,861.46	0.00 (382.53)	183,478.93
LANDFILL/GARAGE	6,185.62	2,016.16	1,719.50	6,482.28	0.00	0.00	6,482.28
STORM WATER	19,259.78	1,566.62	0.00	20,826.40	0.00	0.00	20,826.40
TOTAL	4,437,906.16	298,289.45	359,056.69	4,377,138.92	357.30 (1,103.52)	4,375,678.10

*** END OF REPORT ***

Council Packet

11/3/2016

11-02-2016 10:26 AM

CITY OF RIVERSIDE
 POOLED CASH REPORT (FUND 999)
 AS OF: SEPTEMBER 30TH, 2016

PAGE: 1

FUND ACCOUNT#	ACCOUNT NAME	BEGINNING BALANCE	CURRENT ACTIVITY	CURRENT BALANCE
<u>CLAIM ON CASH</u>				
001-1110	CHECKING ACCT-GENERAL FUND	1,580,291.02	17,110.70	1,597,401.72
110-1110	CHECKING ACCT-ROAD USE TAX	353,688.44	12,806.20	366,494.64
121-1110	CHECKING ACCT-LOST	250,472.68	8,361.89	258,834.57
125-1110	CHECKING ACCT-TIF	0.00	0.00	0.00
145-1110	CHECKING ACCT-CASINO REVENUE	1,020,920.49	75,653.45	1,096,573.94
200-1110	CHECKING ACCT-DEBT SERVICE	0.00	0.00	0.00
301-1110	CHECKING ACCT-CAP PROJECTS	333,603.34 (223,488.39)	110,114.95
600-1110	CHECKING ACCT-WATER	711,863.71	23,606.96	735,470.67
610-1110	CHECKING ACCT-SEWER	161,621.08	21,857.85	183,478.93
670-1110	CHECKING ACCT-GARBAGE	6,185.62	296.66	6,482.28
680-1110	CHECKING ACCT-STORM WATER	19,259.78	1,566.62	20,826.40
TOTAL CLAIM ON CASH		4,437,906.16 (62,228.06)	4,375,678.10

CASH IN BANK - POOLED CASH

999-1110	CASH IN BANK	1,252,337.90 (72,252.58)	1,180,085.32
999-1112	PEOPLES BANK MONEY MARKET	2,074,652.95	1,449.42	2,076,102.37
999-1114	HILLS BANK	561,169.77	8,564.48	569,734.25
999-1115	CB FUND	15,200.59	10.62	15,211.21
999-1116	COMMUNITY BUILDING CD #18936	271,358.97	0.00	271,358.97
999-1117	COMMUNITY BUILDING CD#18975	263,185.98	0.00	263,185.98
SUBTOTAL CASH IN BANK - POOLED CASH		4,437,906.16 (62,228.06)	4,375,678.10

WAGES PAYABLE

999-2010	WAGES PAYABLE	0.00	0.00	0.00
SUBTOTAL WAGES PAYABLE		0.00	0.00	0.00

TOTAL CASH IN BANK - POOLED CASH 4,437,906.16 (62,228.06) 4,375,678.10

DUE TO OTHER FUNDS - POOLED CASH

999-2100	DUE TO OTHER FUNDS	4,437,906.16 (62,228.06)	4,375,678.10
TOTAL DUE TO OTHER FUNDS		4,437,906.16 (62,228.06)	4,375,678.10

Council Packet

11/3/2016

11-02-2016 10:26 AM

PAGE: 2

CITY OF RIVERSIDE
 POOLED CASH REPORT (FUND 999)
 AS OF: SEPTEMBER 30TH, 2016

FUND ACCOUNT#	ACCOUNT NAME	BEGINNING BALANCE	CURRENT ACTIVITY	CURRENT BALANCE
<u>DUE TO POOLED CASH</u>				
001-2020	ACCOUNTS PAYABLE	0.00	0.00	0.00
110-2020	ACCOUNTS PAYABLE	0.00	0.00	0.00
121-2020	ACCOUNTS PAYABLE	0.00	0.00	0.00
125-2020	ACCOUNTS PAYABLE	0.00	0.00	0.00
145-2020	ACCOUNTS PAYABLE	0.00	0.00	0.00
200-2020	ACCOUNTS PAYABLE	0.00	0.00	0.00
301-2020	ACCOUNTS PAYABLE	0.00	0.00	0.00
600-2020	ACCOUNTS PAYABLE	0.00	0.00	0.00
610-2020	ACCOUNTS PAYABLE	0.00	0.00	0.00
670-2020	ACCOUNTS PAYABLE	0.00	0.00	0.00
680-2020	ACCOUNTS PAYABLE	0.00	0.00	0.00
TOTAL DUE TO POOLED CASH		0.00	0.00	0.00

DUE FROM OTHER FUNDS

999-1330	DUE FROM OTHER FUNDS	0.00	0.00	0.00
TOTAL DUE FROM OTHER FUNDS		0.00	0.00	0.00

ACCOUNTS PAYABLE - POOLED CASH

999-2020	ACCOUNTS PAYABLE CONTROL	0.00	0.00	0.00
TOTAL ACCOUNTS PAYABLE POOLED CASH		0.00	0.00	0.00

*** PROOF CASH BALANCES ***

(A)		(B)		(C)	
CLAIM ON CASH	4,375,678.10	CLAIM ON CASH	4,375,678.10	CASH IN BANK	4,375,678.10
CASH IN BANK	4,375,678.10	DUE TO OTHER FUNDS	4,375,678.10	DUE TO OTHER FUNDS	4,375,678.10
DIFFERENCE	0.00		0.00		0.00

*** PROOF ACCOUNTS PAYABLE BALANCES ***

(D)		(E)		(F)	
AP PENDING	0.00	AP PENDING	0.00	DUE FROM OTHER FUNDS	0.00
DUE FROM OTHER FUNDS	0.00	ACCOUNTS PAYABLE	0.00	ACCOUNTS PAYABLE	0.00
DIFFERENCE	0.00		0.00		0.00

*** END OF REPORT ***

Becky LaRoche

From: Licensing@IowaABD.com
Sent: Friday, October 28, 2016 2:33 AM
To: becky@cityofriversideiowa.com
Cc: Licensing@IowaABD.com
Subject: [POSSIBLE SPAM] Liquor License Submitted to Local Authority

The following licenses are completed and awaiting local authority approval:

License #	License Status	Business Name
BC0028691	Submitted to Local Authority	Casey's General Store #2629 (200 E. 1st St. Riverside Iowa, 52327)
BC0028691	Submitted to Local Authority	Casey's General Store #2629 (200 E. 1st St. Riverside Iowa, 52327)

Please do not respond to this email. Contact the Division's Licensing Section with questions regarding the application process or application status toll-free at 866.IowaABD (866.469.2223) (select option 1), locally 515.281.7400 (select option 1).

For assistance by email contact Licensing@IowaABD.com

No virus found in this message.

Checked by AVG - www.avg.com

Version: 2016.0.7859 / Virus Database: 4664/13296 - Release Date: 10/28/16

Lory Young

From: Jim Johnson <publisher@kalonanews.com>
Sent: Monday, October 17, 2016 10:49 AM
To: Lory@CityofRiversideIowa.com
Subject: Request for Official Publication approval

October 17, 2016

Honorable City Council members:

Anamosa Publications Inc. -- owned by Jim and Bridget Johnson -- has purchased the Riverside Current. We have merged the Riverside newspaper into The Kalona News. We are also combining the Wellman Advance, Highland Review and Lone Tree Reporter into The Kalona News. This was done to eliminate duplication among the newspapers, which allows us to provide increased coverage for all of the newspapers.

We think you will find the new newspaper an improvement over the previous Riverside Current.

In essence, the new Kalona News is a continuation of the Riverside Current. With the combined newspaper, The Kalona News has expanded the number of subscribers in Riverside.

The charge for legal advertising should not change, since rates are set by the state.

I request that The Kalona News be named as the official newspaper for the City of Riverside. This is the designation the council gave to the Riverside Current at its organization meeting this year. I would be happy to answer any questions the council may have.

Sincerely,

W. James Johnson

Publisher

No virus found in this message.

Checked by AVG - www.avg.com

Version: 2016.0.7797 / Virus Database: 4664/13227 - Release Date: 10/17/16

RESOLUTION #11072016-01

RESOLUTION APPOINTING NEWSPAPER

WHEREAS, the City of Riverside finds it necessary to designate a newspaper of general circulation within the community as the appropriate entity for the publication of all official notices and proceedings;

NOW, THEREFORE BE IT HEREBY RESOLVED BY THE CITY COUNCIL OF THE CITY OF RIVERSIDE, IOWA, as follows:

The Kalona News, formerly the Riverside Current, be the official weekly newspaper for the City of Riverside, Iowa and that such designation shall be in effect until the first council meeting in January 2017.

IT WAS MOVED BY Councilperson _____, seconded by Councilperson _____ that the foregoing Resolution be adopted.

Roll call: Weber, Schneider, Sexton, Schnoebelen, Redlinger

Ayes:

Nays:

Absent:

PASSED AND APPROVED by the City Council of Riverside, Iowa, on this 7th day of November, 2016.

Signed: _____
Allen Schneider, Mayor

Attest: _____
Lory Young, City Clerk

RESOLUTION #11072016-02

RESOLUTION APPROVING CHANGE ORDER #7 FOR THE ELLA STREET IMPROVEMENTS CONSTRUCTION PROJECT

Whereas, the City of Riverside City at the recommendation of the City Engineering Firm, MMS Consultants, Scott Pottorff and it is the opinion of the City Engineering Firm that the City Council accept this change order in the amount of \$16,816.40 for additional changes at 311 Ella Street for the Ella Street Project.

Therefore, be it resolved the City of Riverside City Council does hereby accept the Change Order #7 in the amount of \$16,816.40 for changes to the project of replacing seeding with sod.

It was moved by Councilperson _____, seconded by Councilperson _____, to approve the foregoing resolution on November 7th, 2016.

Roll Call: Redlinger, Schneider, Sexton, Weber, Schnoebelen

Ayes:

Nays:

Absents:

PASSED AND APPROVED by City Council of Riverside, Iowa, on this 7th day of November, 2016.

Signed: _____

Allen Schneider, Mayor

Attest: _____

Lory Young, City Clerk



MMS Consultants, Inc.
Experts in Planning and Development Since 1975

2245-012

November 2, 2016

**Ella Street Improvements
Change Order #7**

The following changes to the contract are requested for installation of sod instead of seeding for disturbed areas.

It was decided to install sod instead of seeding for the project. The contract changes for the change in work are as follows:

DECREASE

<u>Item</u>	<u>Est Quantity</u>	<u>Unit Price</u>	<u>Total Estimated Cost</u>
Seeding, Fertilizing and Mulching	-1.0 ACRE	\$3,600.00	-\$3,600.00

ADD ITEMS

<u>Item</u>	<u>Est Quantity</u>	<u>Unit Price</u>	<u>Total Estimated Cost</u>
Sod	1.0 ACRE	\$19,166.40	\$19,166.40
Subgrade Prep for Sod	1 LS	\$1,250.00	\$1,250.00

Change to the Contract

This change order would increase the contract amount of the above items and add the above items to the contract and increase the amount of the contract by **\$16,816.40**.

Reason for changes

Since the project is being completed so late in the year, the seeding on the project would have a difficult time getting established. Instead of installing additional erosion control matting and the potential of dealing with erosion through the winter and spring, it was decided to install sod instead to prevent erosion issues and to provide a quality finished product.

Approved by:

Cornerstone Excavating

City of Riverside

2245012changeorder6.docx

Environmental Specialists

Landscape Architects

Land Planners

Land Surveyors

Civil Engineers

RESOLUTION #11072016-03

RESOLUTION APPROVING CHANGE ORDER #8 FOR THE ELLA STREET IMPROVEMENTS CONSTRUCTION PROJECT

Whereas, the City of Riverside City at the recommendation of the City Engineering Firm, MMS Consultants, Scott Pottorff and it is the opinion of the City Engineering Firm that the City Council accept this change order in the amount of \$8,131.60 for additional changes at 311 Ella Street for the Ella Street Project.

Therefore, be it resolved the City of Riverside City Council does hereby accept the Change Order #8 in the amount of \$8,131.60 for changes made to the beehive intake at the SE corner of St. Mary's and Ella Street, pouring of the letdown throat around intake, pouring of additional concrete to fill in triangular areas at the NE corner of the intersection of Ella and Blackberry.

It was moved by Councilperson _____, seconded by Councilperson _____, to approve the foregoing resolution on November 7th, 2016.

Roll Call: Redlinger, Schneider, Sexton, Weber, Schnoebelen

Ayes:

Nays:

Absents:

PASSED AND APPROVED by City Council of Riverside, Iowa, on this 7th day of November, 2016.

Signed: _____

Allen Schneider, Mayor

Attest: _____

Lory Young, City Clerk



MMS Consultants, Inc.
Experts in Planning and Development Since 1975

2245-012

November 2, 2016

Ella Street Improvements
Change Order #8

The following changes to the contract are requested for moving the beehive intake at the SE corner of St. Mary's and Ella Street and pouring the letdown throat around the intake as well as pouring additional concrete to fill in the triangular area at the NE corner of the intersection of Ella and Blackberry.

The contractor performed this work on a time and materials basis since the work included items that were not in the original contract. A breakdown of the costs is shown on the attached sheets. The contract changes for the change in work are as follows:

ADD ITEMS

<u>Item</u>	<u>Est Quantity</u>	<u>Unit Price</u>	<u>Total Estimated Cost</u>
Relocate Beehive, Extend Storm Sewer, Pour Letdown Structure	1 LS	\$7,765.39	\$7,765.39
Fill in Concrete Triangular Area	1 LS	\$366.21	\$366.21

Change to the Contract

This change order would add the above items to the contract and increase the amount of the contract by **\$8,131.60**.

Reason for changes

In working with the property owner it was decided to move the area drain to the east and remove a tree and perform grading work on private property in order to address the property owner's concerns. Since this work included items that were not in the original contract, this work was done on a time and materials basis.

Approved by:

Cornerstone Excavating

City of Riverside

2245012changeorder8.docx

Environmental Specialists

Landscape Architects

Land Planners

Land Surveyors

Civil Engineers

Change Request

To: City of Riverside
 60 North Greene Street
 Riverside, IA 52327

Number: 10/26/2016
 Date: 10/26/2016
 Job: Ella Street Improvement Project
 Job #: WAS013

Description: Removal/relocation of SW-512 intake, 12" RCP and associated concrete work @ SE Side of 4th & Ella as requested and the infill with concrete of triangular section of sidewalk @ the NE corners of Ella and Blackberry as requested

We are pleased to offer the following specifications and pricing to make the following changes:
 Work completed on a T & M basis

Price Excludes:

Description	Quantity	Unit	Unit Price	Price
Relocation of 24" SW-512 Intake Including:	1	LS	\$7,765.39	\$7,765.39
1 Removal of existing intake structure				
2 Installation of additional 12" RCP				
3 Installation of new 24" SW-512 Intake				
4 Form and pour concrete flume and intake pad				
5 Additional grading				
6 Removal of tree				
Infill with concrete triangular space in sidewalk @ NE corner of Ella/Blackberry as requested				
1 Labor and Materials price from Storm Drains Etc.	1	LS	\$366.21	\$366.21
			Total:	\$8,131.60

Submitted by: _____

Approved by: _____

Jim Zieglofsky
 Cornerstone Excavating, Inc.

Date: _____

Scott Pottorff

From: Jim <jimz@cstoneinc.com>
Sent: Thursday, October 27, 2016 11:50 AM
To: Scott Pottorff; 'Glen Meisner'
Cc: 'BJ Miller'; 'Matt Anderson'
Subject: Added work items for Ella Street
Attachments: Change request 10262016.pdf

Scott,

I am still waiting on items and quantities from All American for their work but I am including some of the work we completed on a T & M basis for this project including:

- 1) Relocate existing 24" SW-512 intake, extend the 12" RCP and pour concrete flume and splash pad around the intake
- 2) Pour concrete infill in the sidewalk area @ NE corner of Ella/Blackberry (The triangular section that was originally to be grassed and the city wanted concrete)

My breakdown for these items is as follows:

Intake relocation:

- 1) Storm Drains Etc. invoice for labor and concrete - $\$5803.22 + 10\% = \6383.55
 - 2) New 12" RCP pipe and 24" riser pipe for intake structure - $\$631.84$
 - 3) Removal of existing tree - $\$250.00$
 - 4) Additional grading - $\$500.00$
- TOTAL = $\$7765.39$

Infill sidewalk area @ NE corner of Ella/Blackberry

- 1) Storm Drains Etc. Invoice for labor and concrete - $\$332.92 + 10\% = \366.21

Total change order request = $\$8131.60$

I did not try to fit this into our existing unit prices as they really do not apply to this unique situation. Please let me know if this makes sense or if you need me to provide you with something different. Thank you.

Jim Ziegrowsky
President
Cornerstone Excavating Inc
Ph: (319) 653-3957
Fax: (319) 653-9067

RESOLUTION #11072016-04

RESOLUTION APPROVING CHANGE ORDER #9 FOR THE ELLA STREET IMPROVEMENTS CONSTRUCTION PROJECT

Whereas, the City of Riverside City at the recommendation of the City Engineering Firm, MMS Consultants, Scott Pottorff and it is the opinion of the City Engineering Firm that the City Council accept this change order with no change in contract price for additional changes at 311 Ella Street for the Ella Street Project.

Therefore, be it resolved the City of Riverside City Council does hereby accept the Change Order #9 with no change in contract price for changes made to the contract to pay for granular surfacing material by the ton instead of by the square yard.

It was moved by Councilperson _____, seconded by Councilperson _____, to approve the foregoing resolution on November 7th, 2016.

Roll Call: Redlinger, Schneider, Sexton, Weber, Schnoebelen

Ayes:

Nays:

Absents:

PASSED AND APPROVED by City Council of Riverside, Iowa, on this 7th day of November, 2016.

Signed: _____

Allen Schneider, Mayor

Attest: _____

Lory Young, City Clerk



MMS Consultants, Inc.
Experts in Planning and Development Since 1975

2245-012

November 2, 2016

Ella Street Improvements
Change Order #9

The following changes to the contract are requested to pay for granular surfacing material by the ton instead of by the square yard.

The cost per square yard was converted to tons using 137 lbs/CY for rock material. For 4" thickness material, 1 SY = 9 CF*0.33' thick = 3 CF/SY. At 137 lbs/CF each SY would be 411 lbs or 0.2055 tons. Therefore \$4.50/0.2055 = \$21.90/ ton. For 6" thickness material 1 SY = 9 CF*0.50' thick = 4.5 CF/SY. At 137 lbs/CF each SY would be 616.50 lbs or 0.3083 tons. Therefore \$6.75/0.3083 = \$21.90/ton. The contract changes for the change in work are as follows:

DELETE ITEMS

<u>Item</u>	<u>Est Quantity</u>	<u>Unit Price</u>	<u>Total Estimated Cost</u>
Subbase, Macadam Stone, 6" Thick	623 SY	\$6.75	\$4,205.25
Subbase, Class A Crushed Stone, 4" Thick	623 SY	\$4.50	\$2,803.50

ADD ITEMS

<u>Item</u>	<u>Est Quantity</u>	<u>Unit Price</u>	<u>Total Estimated Cost</u>
Subbase, Macadam Stone, 6" Thick	192.02 TONS	\$21.90	\$4,205.25
Subbase, Class A Crushed Stone, 4" Thick	128.01 TONS	\$21.90	\$2,803.50

Change to the Contract

This change order would add and delete the above items to the contract be **no change in the contract amount.**

Reason for changes

Since the transition areas were small and irregular it was decided to eliminate the macadam stone at some of the transitions and install thicker Class A stone in those areas instead at the request of the seal coat contractor. Since the thickness was hard to measure and the length of some of the transitions were extended it would be easier and more fair to use rock tickets to determine the actual amount of rock used. Based on tickets received so far there were 329.47 tons of Class A (\$7,215.39) and 14.04 tons (\$307.48) of macadam stone used.

Approved by:

Cornerstone Excavating

City of Riverside

2245012changeorder9.docx

Environmental Specialists

Landscape Architects

Land Planners

Land Surveyors

Civil Engineers

RESOLUTION #11072016-05

RESOLUTION APPROVING PAY REQUEST #6 FROM CORNERSTONE EXCAVATING FOR ELLA STREET IMPROVEMENTS PROJECT

Whereas, the City of Riverside City at the recommendation of the City Engineering Firm, MMS Consultants, Scott Pottorff and it is the opinion of the City Engineering Firm that the City Council accept this pay estimate from Cornerstone Excavating for work performed and billed on Pay Request #6 for the Ella Street Improvements Project.

Therefore, be it resolved the City of Riverside City Council does hereby approve this pay request to Cornerstone Excavating for the Ella Street Improvements Project in the amount of \$174,143.82.

Moved by Councilperson _____, seconded by Councilperson _____, to approve the foregoing resolution on November 7th, 2016.

Roll Call: Weber, Schneider, Sexton, Schnoebelen, Redlinger

Ayes:

Nays:

Absents:

Signed: _____

Allen Schneider, Mayor

Attest: _____

Lory Young, City Clerk

CONSTRUCTION PROGRESS PAYMENT

Project Description Ella Street Improvements PN: 2245012
 Contract Date 16-Oct-15
 Contractor: Cornerstone Excavating Owner: City of Riverside
 Address: P.O. Box 928 Attn: _____
 City, St., Zip: Washington, Iowa 52353 Address: 60 N. Greene Street
 Phone: 319-653-3957 City, St., Zip: Riverside, IA 52327
 Fax: 319-653-9067 Phone: 319-648-3501
 Fax: _____

Estimate #	<u>6</u>	FOR PERIOD:	Owner PN
<input checked="" type="checkbox"/>	Partial Payment	FROM: <u>8/22/16</u>	Federal PN
<input type="checkbox"/>	Final Payment	TO: <u>10/28/16</u>	State PN

Base Contract Price	\$1,108,055.85	
Change #	1	\$10,182.60
Change #	2	\$11,000.50
Change #	3	\$5,738.25
Change #	4	\$650.00
Change #	5	\$2,000.00
Change #	6	\$10,496.25
Total Contract	\$1,148,123.45	

Materials on Hand	\$ -
Construction Completed	\$1,155,702.94
Total Earned	\$1,155,702.94
Less Retainage	\$57,785.15
Less Previous Payment	\$923,773.97
Amount Due This Est	\$174,143.82

Requested by: _____
Jim Ziegrowsky
 Title: President
 Date: _____

Recommended by: _____
Scott Pottorff
 Title: Project Engineer
 Date: _____

Approved by: _____
 Title: _____
 Date: _____

Attested by: _____
 Title: _____
 Date: _____

MMS Consultants, Inc.
 1917 South Gilbert Street, Iowa City, IA 52240

i:\proj\forms\payreqst.xls

Ella Street Improvements

6

Pay Estimate No.: Cornerstone Excavating
 Payable to: November 2, 2016
 Date: October 28, 2016
 Week Ending:

Item No.	Item Description	Units	Contract Quantity	Unit Price	Contract Amount	Quantity This Estimate	Amount This Estimate	To Date Quantity	To Date Amount
	Traffic Control	LS	1	\$15,700.00	15,700.00	0.25	3,925.00	1.00	15,700.00
	Mobilization	LS	1	\$72,500.00	72,500.00	-	-	1.00	72,500.00
	Cleaning and Grubbing	LS	1	\$15,000.00	15,000.00	-	-	1.00	15,000.00
	Off Site Topsoil	CY	500	\$34.00	17,000.00	740.00	25,160.00	740.00	25,160.00
	Class 10 Excavation, Import	CY	U.P.O.	\$15.00	-	-	-	-	-
	Excavation, Class 13 ***	CY	2,070	\$10.95	22,666.50	-	-	2,070.00	22,666.50
	Below Grade Excavation (Core Out)	CY	200	\$37.85	7,590.00	-	-	55.00	2,087.25
	Subgrade Preparation	SY	6,038	\$1.80	10,868.40	-	-	6,038.00	10,868.40
	Subbase, Modified, 6" Thick for Full Depth HMA *	SY	126	\$5.75	724.50	-	-	126.00	724.50
	Subbase, Modified, 4" Thick for 6" PCC Sidewalk	SY	1,406	\$5.25	7,381.50	-	-	1,406.00	7,381.50
	Subbase, Macadam Stone, 6" Thick	SY	623	\$6.75	4,205.25	-	-	104.00	702.00
	Subbase, Class A Crushed Stone, 4" Thick	SY	623	\$4.50	2,803.50	-	-	-	-
	Removal of Culverts	EA	22	\$250.00	5,500.00	-	-	22.00	5,500.00
	Backfilling of Curbs	LF	3,438	\$2.00	6,872.00	2,436.00	4,872.00	3,436.00	6,872.00
	Trench Foundation	TONS	50	\$21.50	1,075.00	-	-	-	-
	Replacement of Unsuitable Backfill Material, Granular Backfill	CY	50	\$34.75	1,737.50	-	-	-	-
	Granular Trench Backfill, Class A Roadstone, 8" Sanitary Main	LF	488	\$40.00	19,520.00	-	-	488.00	19,520.00
	Granular Trench Backfill, Class A Roadstone, 12" Storm Sewer	LF	534	\$11.50	6,141.00	-	-	562.00	6,693.00
	Granular Trench Backfill, Class A Roadstone, 18" Storm Sewer	LF	95	\$11.50	1,092.50	-	-	95.00	1,092.50
	Granular Trench Backfill, Class A Roadstone, 24" Storm Sewer	LF	35	\$11.50	402.50	-	-	35.00	402.50
	Granular Trench Backfill, Class A Roadstone, 6" Water Main	LF	120	\$10.00	1,200.00	-	-	120.00	1,200.00
	Granular Trench Backfill, Class A Roadstone, 8" Water Main	LF	40	\$16.75	670.00	-	-	40.00	670.00
	Granular Trench Backfill, Class A Roadstone, 8" Water Main	LF	60	\$16.75	1,005.00	-	-	141.00	2,361.75
	Sanitary Sewer Gravity Main, Trenched, PVC (SDR 26), 8" Dia.	LF	488	\$39.45	19,251.60	-	-	488.00	19,251.60
	Remove Existing Sanitary Sewer	LF	488	\$10.00	4,880.00	-	-	488.00	4,880.00
	Sanitary Sewer Existing Service Lateral Reconnection	EA	8	\$1,125.00	9,000.00	-	-	8.00	9,000.00
	Storm Sewer, Trenched, RCP, 12" Dia.	LF	1,265	\$49.25	62,301.25	-	-	1,265.00	62,301.25
	Storm Sewer, Trenched, RCP, 15" Dia.	LF	391	\$45.00	17,595.00	-	-	391.00	17,595.00
	Storm Sewer, Trenched, RCP, 18" Dia.	LF	348	\$46.75	16,269.00	-	-	348.00	16,269.00
	Storm Sewer, Trenched, RCP, 24" Dia.	LF	293	\$55.75	16,334.75	-	-	293.00	16,334.75
	Removal of Storm Sewer	LF	289	\$12.50	3,612.50	-	-	217.00	2,712.50
	Longitudinal Subdrain, Type 2, 4"	LF	639	\$8.45	5,399.55	-	-	540.00	4,569.00
	Subdrain Cleanout, Type A-1 ***	EA	4	\$425.00	1,700.00	2.00	850.00	3.00	1,275.00
	Subdrain Outlet, Connection to Structure	EA	3	\$225.00	675.00	1.00	225.00	3.00	675.00
	Connect Existing Sump Pump Outlet to Storm Sewer or Subdrain, East Side	EA	2	\$500.00	1,000.00	-	-	3.00	1,500.00
	Connect Existing Sump Pump Outlet to Intake or Subdrain, West Side	EA	2	\$750.00	1,500.00	-	-	5.00	3,750.00
	Water Main, 6", PVC C900	LF	184	\$32.35	5,952.40	-	-	184.00	5,952.40
	Water Main, 8", PVC C900	LF	733	\$35.00	25,655.00	-	-	733.00	25,655.00
	Fire Hydrant Assembly	EA	1	\$4,050.00	4,050.00	-	-	1.00	4,050.00
	Cut in 4"x4" Tee	EA	2	\$3,000.00	6,000.00	-	-	2.00	4,600.00
	Cut in 8"x8" Tee	EA	2	\$3,000.00	6,000.00	-	-	2.00	6,000.00
	Relocate Existing Fire Hydrant Assembly	EA	1	\$1,250.00	1,250.00	-	-	1.00	1,250.00
	Water Service Stub, Main to Curb Stop Short, 1" Copper (Type K)	EA	3	\$1,375.00	4,125.00	-	-	3.00	4,125.00
	Water Service Stub, Main to Curb Stop Long, 1" Copper (Type K)	EA	4	\$1,950.00	7,800.00	-	-	4.00	7,800.00
	Remove Tee and Install Sleeve	EA	2	\$1,100.00	2,200.00	-	-	2.00	2,200.00
	Remove Tee and Valve and Install Sleeve	EA	2	\$1,200.00	2,400.00	-	-	2.00	2,400.00
	Remove Valve Box and Rod	EA	2	\$250.00	500.00	-	-	2.00	500.00
	Gate Valve, 4"	EA	2	\$825.00	1,650.00	-	-	2.00	1,650.00

Item No.	Item Description	Units	Contract Quantity	Unit Price	Contract Amount	Quantity This Estimate	Amount This Estimate	To Date Quantity	To Date Amount
49	Gate Valve, 6"	EA	2	\$925.00	1,850.00	-	-	2.00	1,850.00
50	Gate Valve, 8"	EA	7	\$1,225.00	8,575.00	-	-	7.00	8,575.00
51	Sanitary Manhole, Type SW-301, 48" Dia	EA	2	\$3,400.00	6,800.00	-	-	2.00	6,800.00
52	Storm Manhole, Type SW-301, 48" Dia	EA	7	\$3,000.00	21,000.00	-	-	7.00	21,000.00
53	Storm Manhole, Type SW-301, 48" Dia with SW-604 Type 3B Grate	EA	2	\$3,000.00	6,000.00	-	-	4.00	12,000.00
54	Storm Intake, Type SW-501	EA	1	\$2,975.00	2,975.00	-	-	1.00	2,975.00
55	Storm Intake, Type SW-509	EA	6	\$4,725.00	28,350.00	-	-	6.00	28,350.00
56	Storm Intake, Type SW-512, 24"	EA	11	\$1,875.00	20,625.00	-	-	9.00	16,875.00
57	Storm Intake, Type SW-513, 48"x48"	EA	1	\$3,000.00	3,000.00	-	-	1.00	3,000.00
58	Storm Intake, Type SW-541 with SW-542 Extension	EA	4	\$7,000.00	28,000.00	-	-	4.00	28,000.00
59	Storm Intake, Type SW-545 (12)	EA	1	\$8,600.00	8,600.00	-	-	1.00	8,600.00
60	Storm Intake, Type SW-545 (14)	EA	4	\$8,600.00	34,400.00	-	-	4.00	34,400.00
61	Manhole Adjustment, Minor	EA	1	\$500.00	500.00	-	-	2.00	1,000.00
62	Connect to Existing Manhole	EA	1	\$1,500.00	1,500.00	-	-	-	-
63	Remove Existing Sanitary Manhole	EA	2	\$2,000.00	4,000.00	-	-	2.00	4,000.00
64	Remove Existing Storm Manhole or Intake **	EA	7	\$1,000.00	7,000.00	-	-	8.00	8,000.00
65	PCC Curb and Gutter, 24" Wide	LF	3,436	\$17.75	60,989.00	-	-	3,204.00	56,871.00
66	Granular Surfacing, Class A Crushed Stone	TONS	200	\$16.30	3,260.00	40.00	652.00	40.00	652.00
67	Removal of Pavement, Composite, Highway 22	SY	150	\$16.50	2,475.00	-	-	126.00	2,079.00
68	Composite Pavement, 8" HMA on 7" PCC, Highway 22	SY	150	\$105.00	15,750.00	-	-	126.00	13,230.00
69	HMA Base, 3/4" Mixture, 300K ESAL *	TONS	1,225	\$72.30	88,567.50	733.64	59,424.84	733.64	59,424.84
70	HMA Surface, 1/2" Mixture, 300K ESAL *	TONS	615	\$81.00	49,815.00	38.63	13,056.94	103.13	34,857.94
71	HMA Binder, PG 64-22	TONS	110	\$338.00	37,180.00	61.00	457.50	804.00	6,030.00
72	Removal of Sidewalk	SY	743	\$7.50	5,572.50	-	-	267.00	2,002.50
73	Removal of PCC Driveway ***	SY	267	\$7.50	2,002.50	-	-	468.00	39,819.70
74	Sidewalk, PCC, 5"	SY	420	\$85.45	35,889.00	386.00	32,983.70	468.00	39,819.70
75	Sidewalk, PCC, 6"	SY	1172	\$69.75	81,747.00	117.00	8,160.75	1,259.00	87,815.25
76	Detectable Warning	SF	466	\$47.50	22,087.50	279.00	13,252.50	449.00	21,327.50
77	PCC Driveway, 8" ***	SY	341	\$69.75	23,784.75	204.00	14,229.00	545.00	38,013.75
78	Pavement Scarification	SY	500	\$14.46	7,225.00	-	-	-	-
79	Removal of PCC Curb and Gutter	LF	35	\$10.00	350.00	-	-	35.00	350.00
80	Bituminous Seal Coat	SY	623	\$8.20	5,108.60	-	-	-	-
81	Seeding, Fertilizing and Mulching, Permanent, Type, 1	AC	1.0	\$3,600.00	3,600.00	-	-	-	-
82	SWPPP Management	LS	1	\$4,000.00	4,000.00	0.50	2,000.00	1.00	4,000.00
83	Silt Fence	LF	500	\$2.00	1,000.00	100.00	200.00	100.00	200.00
84	Removal of Silt Fence	LF	500	\$0.50	250.00	-	-	-	-
85	Inlet Protection Device	EA	27	\$60.00	1,620.00	-	-	27.00	1,350.00
86	Inlet Protection Device Maintenance	EA	27	\$25.00	675.00	17.00	425.00	27.00	675.00
87	Painted Pavement Markings, Waterborne or Solvent	S/A	16.32	\$170.30	2,779.30	15.84	2,697.55	15.84	2,697.55
	TOTAL CONTRACT				1,085,988.85				1,094,218.34
C.O.#1	Upsize 48" Storm Manholes to 60"	EA	4,000	\$1,095.65	4,382.60	-	-	4.00	4,382.60
	Additional Tree Removal at 4th and Ella Street	LS	1,000	\$2,850.00	2,850.00	-	-	1.00	2,850.00
	Additional Tree Removal (3 Evergreen Trees), cut down, grade, install downspout connection to ditch	LS	1,000	\$2,950.00	2,950.00	0.25	737.50	1.00	2,950.00
	TOTAL CHANGE C.O.#1				10,182.60		737.50		10,182.60
C.O.#2	Pavement Removal Milling and Stockpile	SY	5,075,000	\$3.90	19,792.50	-	-	5,075.00	19,792.50
	6" Subbase - Placement of Millings	SY	5,075,000	\$2.25	11,418.75	-	-	5,075.00	11,418.75
	Import 6" Base Material (Millings Stockpile or Virgin Modified Subbase)	SY	1,778,000	\$5.75	10,223.50	-	-	1,778.00	10,223.50
	TOTAL CHANGE C.O.#2				41,434.75				41,434.75
C.O.#3	Water Main Additional Fittings and Bends	LS	1,000	\$5,738.25	5,738.25	-	-	1.00	5,738.25
	TOTAL CHANGE C.O.#3				5,738.25				5,738.25
C.O.#4	Grub Tree Stumps	LS	1,000	\$650.00	650.00	-	-	1.00	650.00
	TOTAL CHANGE C.O.#4				650.00				650.00
C.O.#6	Dura Slot Drain	LF	20,000	\$103.50	2,070.00	-	-	20.00	2,070.00
	8" HDPE Drain Tile	LF	36,000	\$26.25	908.00	-	-	36.00	908.00
	Connect to Storm Sewer	LS	1,000	\$500.00	500.00	-	-	1.00	500.00
	Remove and Reinstall Retaining Wall Blocks	LS	1,000	\$650.00	650.00	-	-	-	-
	TOTAL CHANGE C.O.#6				4,129.00				3,479.00

Item No.	Item Description	Units	Contract Quantity	Unit Price	Contract Amount	Quantity This Estimate	Amount This Estimate	To Date Quantity	To Date Amount
	TOTAL CONTRACT WITH CHANGE ORDERS				1,148,123.45		183,309.28		1,155,702.94

* Quantity Change with Change Order #2
 ** Quantity Change with Change Order #5
 *** Quantity Change with Change Order #6

Pay Estimate #1
 Pay Estimate #2
 Pay Estimate #3
 Pay Estimate #4

Retainage _____ 5% \$ 57,765.15
 Total Value of Completed Work Less Retainage \$ 1,097,917.79
 Previous Payments \$ 923,773.97
 Current Payment Due \$ 174,143.82

\$ 137,636.14
 \$ 282,834.37
 \$ 170,071.75
 \$ 66,456.06

Lory Young

From: Dennis White <DWhite@peopleservice.com>
Sent: Tuesday, October 25, 2016 2:55 PM
To: Lory Young (lory@cityofriversideiowa.com)
Cc: Bill Stukey
Subject: Nov. 7th, 2016 Council meeting issues from PeopleService
Attachments: Riverside EP Service Agreement Quote Oct. 2016.docx; Riverside IA Fluidyne Service Proposal_10202016.pdf; Riverside, IA Pump Works Oct 2016 SA.pdf; PeopleService Riversidr Lift Station Cleaning Proposal from Visu-Sewer Oct 2016.pdf; _Certification_.htm

Follow Up Flag: Follow up
Flag Status: Flagged

Categories: Red Category

Lory

I would like to ask you to pass this information along to the City Council for their November 7th 2016 council meeting as we would like the Council to take some action on some items we have listed. I know we have not been in full operation a month yet but some issues have come up that we fill need action or we would like direction on, or would like some informational status about those issues

1. Lift Station Cleaning, Pump and control inspection. As we have sent other email concerning the condition and status of the 5 lift station we think the City Council needs to approve to have all 5 stations jet-vac cleaned and have the pumps and controls inspected. We have attached one bid estimate from one cleaning company and currently have 2 verbal bids from two other companies. The attached bid is from Visu-Sewer at \$285.00 per hour, Municipal Pipe and tool is \$325.00 per hour for one person, Hydro-View is currently at \$325 with 2 people and he is the general local area vendor. It is estimated this work will take 12 to 20 hours based on time to get to Riverside to do the job. So if we use the low price of \$285 at 20 hours the cost would be around \$5,700 for the cleaning at worst case based on this information. The Pump and Control Inspection we currently have 2 written bids. One from Iowa Pump works for all 5 lift station at a price of \$2,943 for inspection and oil change if needed, Electrical Pump for all 5 station at a price of \$1,612, Mississippi Valley Pump has not responded yet with a price. Keep in mind some of the price may go up if the pump company needs to go down into the lift station as there are extra charges for things like that plus any parts that may be needed. But for pump and control inspection these are some of the best prices I have seen in a long time. So if we use the lowest price of both bids that we currently have the total estimated cost to get this done is around \$7,312.00 which equals around \$1,462 per station. That is a good price.
2. Also please find attached a bid from Fluidyne Corp who is the company that designed your Wastewater SBR plant. The bid is to have a Fluidyne Tech come to Riverside and check the SBR system to insure it is set to the correct and accurate settings. We have had our PSI company expert with SBR come to Riverside and spend 2 days going over your system and he found things that were not set right in his opinion as he understands SBR's. We have also talked with Fluidyne on the phone about some of the issues and they have suggested the best thing to do is have them come and check the system over and at that time we can also get some training on your system and what setting your system needs to be at. The price for a day of service is \$950 for the service tech. In our opinion your system needs to be evaluated to insure it is a proper settings.

3. The City has a metal locator that is used to find curb boxes, manholes and other types of pipes and other things that are underground. This is a piece of equipment that is as part of your operation and is needed. The locator is in poor condition and has age and based on my experience will cost more to repair it then it is worth. I have sent other locators in to a service dept. a spent over \$600 in repair only to have the unit have the same or another issues 6 to 9 months later and be told it was non-repairable. In many cases just to send it in for evaluation can cost up to \$200 to get checked out. A new unit is around \$1,000 to replace and come with a warranty. In my opinion the City needs to replace this unit as the best option. We therefore would ask for approval to order a new unit and we will work to try to get a discount for the City.

4. We know the City has been working to move forward and spent many hours on approving a new meter replacement program with a new ARM system. We are wondering what the status is of this program is we will have some involvement in the process. In most cases as the company that you hire to install the meter comes to a house that might require that water to be turned off outside at the curb box because of a bad inside valve we (PSI) will in most cases be the ones that do the shut off for the meter install company. There are other aspects that we try to help out with during this process as well. We also know this process can take 30 to 90 days or more to complete by some companies and that doing some of these task in the deep dead of winter makes the process go a lot slower. We also know if you wait until spring to start this process you may wait a long time as everyone wants to do these projects in the better time of the year. This year has been very warm late in the year and is still a good time to start this type of project and if this project has already been approved as I understand this might be the best time to get the ball rolling so to speak.

Next month Bill Stukey will be providing you with your first full operation report and provided additional information on these and other operational issues.

I appreciate your time and consideration in these important issues and look forward to your response.

If you have any question please let me know.



*Service you can depend on.
People you trust.*

PeopleService.com



Dennis White
Region Manager

☎ 319-226-4830
☎ 319-404-0340

3336 Kimball Avenue, Suite 153
Waterloo, IA 50702

dwhite@peopleservice.com

NOTICE: This e-mail message (including any file attachment) is intended only for the use of the individual or entity to which it is addressed, and may contain information that is privileged and/or confidential. If you are not the intended recipient, any dissemination, distribution or copying of this communication is strictly prohibited. If you received this communication in error, please notify us immediately by reply e-mail and delete or destroy all copies of this message and any file attachment. Thank you!

NOTICE: This e-mail message (including any file attachment) is intended only for the use of the individual or entity to which it is addressed, and may contain information that is privileged and/or confidential. If you are not the intended recipient, any dissemination, distribution or copying of this communication is strictly prohibited. If you received this communication in error, please notify us immediately by reply e-mail and delete or destroy all copies of this message and any file attachment. Thank you!



ELECTRIC PUMP

PUMP MAINTENANCE SERVICE AGREEMENT

Date: October 24, 2016

To: Riverside / People's Service
Riverside, IA 52327

Contact: Bill Stukey
Phone: 319-800-3281
Email: *bstukey@peopleservice.com*

Location: Lift Stations 1-5

Equipment Included: Qty (2) Fairbanks Morse 50hp, Qty (2) Fairbanks Morse 10hp, Qty (3) Flygt 3153 20hp, Qty (2) ABS 6.2hp, Qty (2) Flygt 60 hp, Qty (1) JWC grinder

Electric Pump is pleased to offer a pump service agreement. The agreement shall include for one (1) year:

- 1 Inspections:** Including the checkpoints, listed trip charges and labor to inspect unit(s).

PUMP INSPECTION LIST

- 1. Check electrical condition of insulation on power cable and on power cable and on all phases of motor windings (resistance check).**
- 2. Check for any loose or faulty electrical connections within the pump control panel.**
- 3. Check voltage supply between all phases on the line side of the electrical control panel; pump off.**
- 4. Check amperage draws on all phases of the pump motor.**
- 5. Check voltage between all phases on the load side of the pump control (line side for sing phase), pump off.**
- 6. Check condition and operation of motor thermal protectors (if so equipped).**
- 7. Removal of pump from lift station for physical inspection.**
- 8. Check condition of upper shaft seals (inspect condition of oil).**
- 9. Check condition and operation of leakage detector (if so equipped).**
- 10. Check lower shaft seals (inspect condition of oil).**
- 11. Change oil (if required)**
- 12. Check for worn or loose impeller.**
- 13. Check all impeller wear rings.**
- 14. Check for noisy upper and lower bearings.**
- 15. Check physically for damaged or cut pump cable.**
- 16. Clean, reset and check operation of the level sensors.**
- 17. Check for correct shaft rotation.**
- 18. Reinstall pump and check for leakage at the discharge connection.**
- 19. Test of operating cycle.**

This agreement price includes all trip charges, overnight stays and service time for inspections only. A written report of our findings will be supplied to the owner. Prior to all inspections, the owner will be notified of our impending visit. This agreement price does not include any parts, extra labor or return trips that would be required as a result of the inspection or service time.

ANNUAL SERVICE RATE \$ 1,612.75

WOULD YOU LIKE TO ELECT A THREE YEAR SERVICE AGREEMENT AT THE GUARANTEED RATE LISTED ABOVE?

X _____
TERMS

Payment terms are NET THIRTY (30) DAYS.

Any additional repairs and/or parts replacement will be performed only when it is requested by the customer.

Electric Pump assumes no liability for loss of use, any direct, indirect or consequential damage of any kind in respect to the use or operation of pumps or any equipment or accessories used in connection therewith.

The owner's responsibilities will be:

- 1) Dispose of waste.
- 2) Have a representative available to allow entry to pumps.

All parts and labor are subject to the manufacturer's published warranty.

This agreement shall be effective from its signed date and shall continue in effect until termination by mutual agreement or by either party upon thirty (30) days prior written notice.

Service Coordinator
Electric Pump

Pete Lies
Fx: 515-265-8079
petel@electricpump.com

ACCEPTED THIS DATE: _____

COMPANY/CITY: _____

BY: _____

TITLE: _____



SCHEDULED PUMP MAINTENANCE AGREEMENT

Date Prepared: 10/18/2016 Estimate #:7069
 Prepared By: Tim
 Representative: Tony
 Total Number of Stations: 5
 Number of Pumps to be Inspected: 11
 Number of Inspections Per Year: 1
 Months that Service be Performed: Customer Choice
 Fee for this Service Agreement: \$2943.00 Per Inspection, includes confine space and overnight stay.

Maintenance for pumps. Pump info will be documented at time of service.

Pump Model(s):	ABS, Fairbanks, Flygt	Customer Name:	City of Riverside, IA-PeopleService
Serial Number:	Will receive upon inspection	Contact Name:	Bill Stukey
Horse Power:	4:1-10; 3:11-25; 4:26+	Email:	bstukey@peopleservice.com
Impeller Number:	Will receive upon inspection	Phone Number:	319-648-2094(O); 319-800-3281 (C)
Station Locations:	Bike Trail, Casino, COOP, HWY 22	Fax Number:	unknown

TERMS

Any additional repairs (service labor, parts and trip charges) will be performed only after authorization and will be an additional charge. Pumps in dry pit stations shall be inspected in the station, and not removed. If confined space entry is required, an additional fee of \$175 per station entered shall be charged.

This agreement price includes all trip charges, overnight stays and service time. A written report of the findings will be supplied to the owner. Prior to all inspections, the owner will be notified of our impending visit.

All unscheduled emergency calls and repairs are in addition to this periodic preventative maintenance agreement.

All parts and labor are subject to the manufacturer's published warranty.

The fee for this maintenance agreement shall be guaranteed for two years and payable when the service is performed and billed. Payment terms are Net 30. **If you would like to elect a three year service agreement at the guaranteed pricing listed above, please check this box.**

Iowa Pump Works assumes no liability for loss of use or for any direct, indirect or consequential damage of any kind with respect to the use or operation of pumps, any equipment or accessories covered in this agreement.

This agreement shall be effective from its signed date and shall continue in effect until termination by either party upon 30 days prior written notice.

The owner's responsibility will be:

- A) Have a representative available to allow entry to pumps.
- B) Disposal of all waste.

Accepted by: _____ Title: _____ Date: _____

A signed and dated copy of this maintenance agreement must be faxed to (866) 961-5085 or emailed to Iowa Pump Works at info@iowapumpworks.com. The effective date of the maintenance agreement will be the date the form is signed, dated and returned.



825 SW Ordnance Rd.
Ankeny, IA 50023
Telephone (515) 865-5147
info@iowapumpworks.com

Waste Water Pumping Station Service Agreement

As a continuing service to our customers, Iowa Pump Works is pleased to provide an added value service agreement. Your pumping equipment is designed for years of dependable service. But it does require periodic preventative maintenance. Instead of running your equipment until it breaks down, causing sewer backup, emergency service or litigation, consider having Iowa Pump Works dispatch a factory trained Service Technician, equipped and certified for confined space entry, on a predefined schedule. Prior to our coming out to service your system, our technician will, of course, call you to schedule a mutually agreeable date and time for you or your personnel to meet us at the site.

At your option, once, twice or three times a year (depending upon your pump station usage) Iowa Pump Works will perform a 21 point inspection on the mechanical and electrical components of your system and give you an evaluation report. Damaged or worn components will be listed, but only repaired after you agree to the repairs. Charges for repairs will be at our usual field service hourly rate plus parts; but you will save emergency costs resulting from a break down situation type of repair. Also, keep in mind that a pump running in top condition is hydraulically more efficient and electrically less expensive to operate.

We can, at the same time, train you or your people so they will be effective in trouble shooting and operating the equipment. The result is years of worry free performance.

A pre-arranged Service Agreement for each pump station serviced is a very cost-effective approach to maintenance.

We believe you will find this offer of great value and urge you to promptly return the enclosed forms for inclusion in our service schedule. Your service agreement will be effective once we received a signed and dated copy of this service agreement back from you.

You will be billed for the Service Agreement only after it has been performed, and you will only pay for services rendered.

**IOWA PUMP WORKS
FLUID HANDLING SERVICE PROFESSIONALS**

SCOPE

The scheduled preventative maintenance check as described in our Service Agreement will consist of a complete and thorough 20-point mechanical and electrical inspection of each pump station. This inspection will be on a scheduled basis followed by a complete report of the findings. All inspections are based upon agreements of both parties involved and in compliance with services and terms with services stated below.

1. Check electrical condition of insulation on power cable and on all phases of motor windings. (resistance checks)
2. Check for function of control panel and any loose or faulty electrical connections.
3. Check voltage supply between all phases on the line side of the electrical connections.
4. Check amperage draws on all phases of the pump motor.
5. Check voltage between all phases of the load side of the pump motor starter. Check power control.
6. Check condition and operation of motor thermal protectors. (if so equipped)
7. Removal of pump from lift station for physical inspection. (if a submersible pump on guide rails only)
8. Check condition for upper shaft seals. (inspect condition of motor housing, if so equipped)
9. Check condition and operation of moisture sensors. (if so equipped)
10. Check lower shaft seals. (inspect condition of oil if so equipped).
11. Change oil (if required)
12. Check condition of impeller. (on submersible pump on guide rails)
13. Check all impeller wear rings. (on submersible pump on guide rails)
14. Check for noisy upper and lower bearings. (Grease bearings if possible)
15. Check physically for damaged or cut pump cable.
16. Clean, reset, and check operation of the pump alternator and level sensors.
17. Check for correct shaft rotation.
18. Re-install pump and check for leakage at the discharge connection. (if a submersible pump)
19. Test of operating cycle.
20. Perform a pump-down test to document pump flow.
21. Submit complete inspection report.

Business Credit Application

Name/Address

Last:	First:	Middle Initial:	Title
Name of Business:			Tax I.D. Number
Address:			
City:	State:	ZIP:	Phone:
Email Invoices to:			Fax:

Company Information

Type of Business:	In Business Since:		
Legal Form Under Which Business Operates:			
Corporation <input type="checkbox"/>		Partnership <input type="checkbox"/>	Proprietorship <input type="checkbox"/>
If Division/Subsidiary, Name of Parent Company:		In Business Since:	
Name of Company Principal Responsible for Business Transactions:			Title:
Address:	City:	State:	ZIP: Phone:
Billing Address (if different than above):			
Address:	City:	State:	ZIP: Phone:

Bank References

Banker Name:	Contact Phone:	Contact Fax Number	
Checking Account #:	Savings Account #:	Line of Credit	LOC Balance:
Bank Name:	Address:	City, State, Zip	
Email:			

Trade References

Company Name:	Company Name:	Company Name:
Contact Name:	Contact Name:	Contact Name:
Address:	Address:	Address:
Phone: Fax:	Phone: Fax:	Phone: Fax:
Account Opened Since:	Account Opened Since:	Account Opened Since:
Credit Limit:	Credit Limit:	Credit Limit:
Current Balance:	Current Balance:	Current Balance:

I hereby certify that the information contained herein is complete and accurate. This information has been furnished with the understanding that it is to be used to determine the amount and conditions of the credit to be extended. Furthermore, I hereby authorize the financial institutions listed in this credit application to release necessary information to the company for which credit is being applied for in order to verify the information contained herein.

Signature

Date

****Tax exempt form must be supplied or applicable state/city taxes will be applied to all invoices****

Lory Young

From: Dennis White <DWhite@peopleservice.com>
Sent: Wednesday, October 19, 2016 9:47 AM
To: Lory Young (lory@cityofriversideiowa.com)
Cc: Bill Stukey; Tony Harms (tonyh@iowapumpworks.com)
Subject: FW: Riverside, IA Service Agreement Proposal
Attachments: Riverside, IA SA.pdf; IPW-SA Cover Letter Scope Documents.pdf; IPW CREDIT APP.pdf; _Certification_.htm

Lory

Please find attached a bid for the pump service work from Iowa Pump for the 5 Riverside lift station that we have discussed.

As I receive the others I will forward them as well.



Dennis White
Region Manager

☎ 319-226-4830
 ☎ 319-404-0340

*Service you can depend on.
 People you trust.*

PeopleService.com



3336 Kimball Avenue, Suite 153
 Waterloo, IA 50702
dwhite@peopleservice.com

NOTICE: This e-mail message (including any file attachment) is intended only for the use of the individual or entity to which it is addressed, and may contain information that is privileged and/or confidential. If you are not the intended recipient, any dissemination, distribution or copying of this communication is strictly prohibited. If you received this communication in error, please notify us immediately by reply e-mail and delete or destroy all copies of this message and any file attachment. Thank you!

From: Tim Turnbull [<mailto:timt@iowapumpworks.com>]
Sent: Tuesday, October 18, 2016 2:11 PM
To: Bill Stukey <BStukey@peopleservice.com>
Cc: Tony Harms <tonyh@iowapumpworks.com>; David Morgan <davem@iowapumpworks.com>; Dennis White <DWhite@peopleservice.com>
Subject: Riverside, IA Service Agreement Proposal

Bill,
 Iowa Pump Works, Inc. is pleased to offer the attached Service proposal for the City of Riverside lift stations. I have also attached our scope of work we perform. In addition, I have attached a credit application to have the top two sections filled out and returned to me along with a copy of the city's tax exemption certificate. Thank you for this opportunity and we look forward to working with you.

Tim

Iowa/Minnesota Pump Works
 825 SW Ordnance Rd
 Ankeny, Iowa 50023
 P: 515.635.0025



Visu-Sewer
Inspect. Maintain. Rehabilitate.

Proposal

To: Dennis White
People Service, Inc
3336 Kimball Avenue
Waterloo, IA 50702
319-226-4830

From: Bob Moen
Visu-Sewer, Inc.
1065 15th Street SW
Mason City, IA 50401
319-226-4830

Date: 10/1/2016

Project: Sanitary Sewer Lift Station Cleaning

Visu-Sewer is pleased to offer the following service:

Vacuum extraction of debris from five (5) sanitary sewer lift stations, in The City of Riverside. Project shall consist of, pressure washing, scraping grease from walls, and vacuum extraction of debris using man entry and a high volume vacuum system.

T&M Rate- \$285.00 per hour (port to port)

People Service will need to provide access to all manholes, detailed maps, water from nearby hydrants (without charge), a dump site for captured debris, and traffic control beyond signs and cones.

Thank you for the opportunity to quote on this project. If you have any questions, please do not hesitate to call us at 641-425-2788.

All material guaranteed to be as specified. All work to be completed in a substantial workmanlike manner according to specifications submitted, per standard practices. Any alteration or deviation from above specifications involving extra costs will be executed only upon written orders, and will become an extra charge over and above the estimate. All agreements contingent upon strikes, accidents or delays beyond our control. Owner to carry fire, tornado and other necessary insurance. Our workers are fully covered by Workmen's Compensation Insurance. This proposal may be withdrawn if not accepted within 30 days of issue. Time and material rates are charges "port to port". Terms - Net 30 days.

Acceptance of Proposal

The above prices, specifications and conditions are satisfactory and are hereby accepted. Visu-Sewer, Inc. is authorized to do the work as specified.

Date: _____ Signature: _____

Lory Young

From: Dennis White <DWhite@peopleservice.com>
Sent: Thursday, October 20, 2016 4:41 PM
To: Lory Young (lory@cityofriversideiowa.com); Bill Stuken
Subject: FW: Riverside IA
Attachments: Riverside IA Service Proposal_10202016.pdf; _Certification_.htm

Please see attached a proposal from Fluidyne Corp. to come to Riverside and do some Wastewater SBR plant adjustments to the system, as we have found some items that do not appear to be normal. They will also update and provide training on your system. This will be a City expenses or we can charge this to the contract maintenance budget if the City would prefer.

Please let me know when this is approved so we can get it planned.

Thanks



Dennis White
Region Manager

☎ 319-226-4830
 ☎ 319-404-0340

*Service you can depend on.
 People you trust.*

PeopleService.com



3336 Kimball Avenue, Suite 153
 Waterloo, IA 50702
dwhite@peopleservice.com

NOTICE: This e-mail message (including any file attachment) is intended only for the use of the individual or entity to which it is addressed, and may contain information that is privileged and/or confidential. If you are not the intended recipient, any dissemination, distribution or copying of this communication is strictly prohibited. If you received this communication in error, please notify us immediately by reply e-mail and delete or destroy all copies of this message and any file attachment. Thank you!

From: Targie Mandt [<mailto:targiem@fluidynecorp.com>]
Sent: Thursday, October 20, 2016 4:07 PM
To: Dennis White <DWhite@peopleservice.com>
Cc: Erick Mandt <erickm@fluidynecorp.com>
Subject: Riverside IA

Hello Dennis,

Please see attached proposal for your consideration. We gave you a break and did not charge for any travel and living expenses.

Thank You,

TARGIE MANDT
 Director Of Technical Services

targiem@fluidynecorp.com | fluidynecorp.com | 319.266.9967 ext. 14

FLUIDYNE CORPORATION

5436 Nordic Drive, Suite D Street Cedar Falls, IA 50613
Phone: (319) 266-9967 Fax: (319) 277-6034
<http://www.fluidynecorp.com>



PROPOSAL

FLUIDYNE CORPORATION (HEREINAFTER CALLED THE COMPANY) AGREES TO SELL TO THE PURCHASER AND THE PURCHASER AGREES TO BUY AND ACCEPT FROM THE COMPANY, THE ITEM (S) DESCRIBED HEREIN.

PROJECT: **Riverside, IA
Wastewater Treatment Plant
Fluidyne ISAM™ System**

PROPOSAL NO.: FLC 102016

DATE WRITTEN: October 20, 2016

WRITTEN BY: Targie Mandt
Fluidyne Corporation
Cedar Falls, Iowa

FLUIDYNE CORPORATION
5436 NORDIC DRIVE, SUITE D
CEDAR FALLS, IOWA 50613
(319) 266-9967

PROPOSAL NO.: FLC 102016
PROJECT: Riverside, IA
DATE: October 20, 2016

Fluidyne Corporation is pleased to quote the following proposal for service for the Fluidyne ISAM™ System in Riverside, IA.

- 1) Half (0.5) day of plant evaluation and operator training. This would include but is not limited to the following:
 - a. Operation of Fluidyne equipment
 - b. Process control & solids management specifically related to Fluidyne System
 - c. Maintenance of mechanical equipment & controls
 - d. Controls, adjustment and description of set points, in/out of service, independent modes, alternating modes, aeration modes, storm modes, level adjustment, decant rates, troubleshooting, operator calculators and guides as they pertain to Fluidyne SBR
- 2) One (1) service report with evaluation & recommendations.
- 3) Two (2) hours of travel four (4) hours total to and from site location.

PRICE:

The price for the above service is \$950 and includes travel and living expenses.

CLARIFICATIONS:

- Any additional field service is charged at \$1050 per day plus travel and living expenses.
- No equipment or programming service work is included in this proposal.

EXCLUSIONS: Not furnished by Fluidyne are the following; chemical feed equipment; any pipe, supports, fittings or valves except those specifically included above; out of basin piping, valving or supports; lift station including pumps and controls; anchor bolts; remote panels, disconnects or junction boxes; conduit and wiring external to the control panel; freeze protection or heat tracing; interconnecting hardware and gaskets; hand railing or fencing; control building and accessories; phone line and accessories; effluent sampler and accessories; electrical and mechanical installation labor; off-loading of equipment; jobsite testing; jobsite storage; taxes; duties; insurance and other items not specifically mentioned in the body of this proposal.

SHIPMENT: The price quoted is based on a target date of 3 to 6 weeks after receipt of signed proposal.

FLUIDYNE CORPORATION
5436 NORDIC DRIVE, SUITE D
CEDAR FALLS, IOWA 50613
(319) 266-9967

PROPOSAL NO.: FLC 102016
PROJECT: Riverside, IA
DATE: October 20, 2016

TAXES: Any applicable duties, sales, use, excise or similar taxes are not included in the quoted price.

TERMS OF PAYMENT: Warranties shall apply only when payments are made in full and according to the following schedule:

100% Net 30 days after site visit

Unless other terms are specified, all payments shall be in United States Dollars and pro rate payments shall become due as deliveries are made. If date of delivery is delayed by purchaser, date of readiness for delivery shall be deemed date of delivery for payment purposes. If purchaser delays manufacture, a payment shall be made based on the purchase price and percentage of completion, balance payable in accordance with the terms stated. Title shall not pass to purchaser or end user until all payments including final payment and any retention for all goods and services have been received in full by Fluidyne.

If, at any time in Company's judgment, purchaser may be or may become unable or unwilling to meet the terms specified, Company may require satisfactory assurances of full or partial payment as a condition of commencing of continuing manufacture; or in advance of shipment, if shipment has been made, recover the product(s) from the carrier.

DURATION: This proposal shall remain in effect for 30 days after proposal date, unless changed in the interim upon written notice.

**FLUIDYNE CORPORATION
5436 NORDIC DRIVE, SUITE D
CEDAR FALLS, IOWA 50613
(319) 266-9967**

**PROPOSAL NO.: FLC 102016
PROJECT: Riverside, IA
DATE: October 20, 2016**

**FLUIDYNE CORPORATION
TERMS OF SALE**

The conditions stated below shall constitute a part of the agreement resulting from the acceptance of an order for the whole or any part of the equipment covered by this quotation.

1. ACCEPTANCE:

All orders shall be made out to Fluidyne Corp., 5436 Nordic Drive, Suite D, Cedar Falls, Iowa 50613, and shall be subject to acceptance by Fluidyne. Orders may not be canceled without Fluidyne's written consent, and then only on terms indemnifying Fluidyne against loss. Fluidyne reserves the right to correct any typographical or clerical errors in the proposal, pricing, or specification. Acceptance of any contract by Fluidyne shall be contingent upon credit approval. Performance shall be subject to strikes, fires, accidents, or curtailments in manufacturing or due to delays unavoidable or beyond the control of Fluidyne. No direct or liquidated damages or penalties shall be accepted. Receipt of the original copy of this proposal, signed by the purchaser, shall constitute a purchase order. The drawings and bulletin illustrations submitted with this proposal shall be general type, arrangement and approximate dimensions of the equipment to be furnished. Fluidyne reserves the right to alter such details in design or arrangement of its equipment, which in its judgment would constitute an improvement in construction, application or operation. Fluidyne shall promptly forward all necessary engineering information for installation of its equipment to the purchaser upon receipt of this accepted proposal. Any changes in equipment, arrangement of equipment, or application of equipment requested by purchaser after acceptance of proposal will be made at purchaser's expense.

2. TAXES

The prices quoted are subject to any addition, which may be necessary to cover any tax charge now existing or hereafter imposed by Federal, State, or Municipal authorities upon equipment or services herein described or the production, sale, distribution or delivery thereof, or upon any feature of this transaction.

3. BINDING RESPONSIBILITIES:

Sales representatives are not authorized to bind us. Typographical errors are not binding.

4. CANCELLATION:

After acceptance, an order shall not be subject to cancellation unless cancellation charges are borne by the Purchaser for work done by the Seller up to the time of receipt of cancellation notice; nor shall such orders be subject to change unless price increases are born by the Purchaser.

**FLUIDYNE CORPORATION
5436 NORDIC DRIVE, SUITE D
CEDAR FALLS, IOWA 50613
(319) 266-9967**

**PROPOSAL NO.: FLC 102016
PROJECT: Riverside, IA
DATE: October 20, 2016**

5. SHIPMENT AND DELIVERY:

All deliveries quoted are estimates based on Fluidyne's best judgment at the time of this proposal, but shipment on these dates is not guaranteed. Deliveries are figured from date of receipt in Cedar Falls, Iowa of approved order and technical data. Fluidyne will not accept any claims caused by delay in shipment or delivery. It is further understood that storage charges of 1 percent per month will apply commencing 30 days from date of equipment completion if purchaser asks the delivery be delayed after production is started. Billing will be made at time of completion of equipment and paid per standard terms.

6. TERMS OF PAYMENT:

Terms of payment are as stipulated in the body of this proposal. Accounts not paid on net cash due date bear interest at the rate of 1.5 percent per month not to exceed the maximum permissible by law. Title shall not pass to purchaser or end user until all payments including final payment and any retention for all goods and services have been received in full by Fluidyne.

7. INSTALLATION AND INITIAL OPERATION:

All equipment shall be installed by and at the expense of the Purchaser unless otherwise stipulated. The Seller will furnish at its option, engineers to supervise the installation and starting up of the equipment. Field service will be provided by a factory-trained representative at a per diem rate of \$850.00 plus travel and expenses on any additional period not stated in this contract.

8. WARRANTY:

Fluidyne warrants the equipment proposed and described herein against defects in material and workmanship under normal service for a period of one year after date of start-up, not to exceed eighteen months from date of shipment. Parts of products manufactured by others and provided by Fluidyne are warranted only to the extent of the original manufacturer's warranty. This warranty is valid provided that the installation operation and maintenance of the equipment is made in accordance with Fluidyne's instructions. The purchaser must promptly give written notice of any equipment defects to Fluidyne. Under warranty, Fluidyne will provide, without cost to the purchaser, such replacement parts as may be required to repair or replace the defective equipment. All labor as may be required to make such replacements must be made by purchaser unless stated otherwise in this proposal. Qualified Fluidyne personnel or its agents must perform all startup service, or this warranty is void. Fluidyne will not warrant nor replace any material involved when repairs are made without prior written authorization from Fluidyne.

**FLUIDYNE CORPORATION
5436 NORDIC DRIVE, SUITE D
CEDAR FALLS, IOWA 50613
(319) 266-9967**

**PROPOSAL NO.: FLC 102016
PROJECT: Riverside, IA
DATE: October 20, 2016**

THIS IS FLUIDYNE'S SOLE WARRANTY. FLUIDYNE MAKES NO OTHER WARRANTY OF ANY KIND, IMPLIED OR EXPRESSED: ALL IMPLIED OR EXPRESSED WARRANTY MADE BY ANY PERSON, AGENT OR REPRESENTATIVE WHICH EXCEEDS FLUIDYNE'S AFOREMENTIONED OBLIGATION ARE HEREBY DISCLAIMED BY FLUIDYNE AND EXCLUDED FROM THIS WARRANTY.

9. PATENTS:

The equipment provided by Fluidyne may be covered by patents pending or issued. Fluidyne grants the right to use this equipment without further charges. Fluidyne does not grant rights to use, royalties, or protection against patent litigation arising from use of this equipment in patented processes controlled by others unless otherwise listed above.

SUBMITTED BY: FLUIDYNE CORPORATION
DATE: October 20, 2016
PROJECT: Riverside, IA

This proposal requires a signature and date along with a purchase order number, billing address and shipping address.

ACCEPTED BY: _____
(Sign and Title)

(Company Name)

DATED: _____

Enter PO#: _____

Enter Billing Information (or attach as required):

Enter Shipping Information (or attached as required):

Lory Young

From: Dennis White <DWhite@peopleservice.com>
Sent: Thursday, October 20, 2016 4:41 PM
To: Lory Young (lory@cityofriversideiowa.com); Bill Stucky
Subject: FW: Riverside IA
Attachments: Riverside IA Service Proposal_10202016.pdf; _Certification_.htm

Please see attached a proposal from Fluidyne Corp. to come to Riverside and do some Wastewater SBR plant adjustments to the system, as we have found some items that do not appear to be normal. They will also update and provide training on your system. This will be a City expenses or we can charge this to the contract maintenance budget if the City would prefer.

Please let me know when this is approved so we can get it planned.

Thanks



*Service you can depend on.
People you trust.*

PeopleService.com



Dennis White
Region Manager

☎ 319-226-4830
☎ 319-404-0340

3336 Kimball Avenue, Suite 153
Waterloo, IA 50702
dwhite@peopleservice.com

NOTICE: This e-mail message (including any file attachment) is intended only for the use of the individual or entity to which it is addressed, and may contain information that is privileged and/or confidential. If you are not the intended recipient, any dissemination, distribution or copying of this communication is strictly prohibited. If you received this communication in error, please notify us immediately by reply e-mail and delete or destroy all copies of this message and any file attachment. Thank you!

From: Targie Mandt [<mailto:targiem@fluidynecorp.com>]
Sent: Thursday, October 20, 2016 4:07 PM
To: Dennis White <DWhite@peopleservice.com>
Cc: Erick Mandt <erickm@fluidynecorp.com>
Subject: Riverside IA

Hello Dennis,

Please see attached proposal for your consideration. We gave you a break and did not charge for any travel and living expenses.

Thank You,

TARGIE MANDT
Director Of Technical Services

targiem@fluidynecorp.com | fluidynecorp.com | 319.266.9967 ext. 14

RESOLUTION #11072016-03

RESOLUTION TO APPROVE BUILDING PERMIT APPLICATION AND FEES

Whereas, the City of Riverside City Council approves the Building Permit application and fee schedule effective November 7th, 2016.

Therefore, be it resolved the City of Riverside City Council does hereby approve the Building permit application and fees.

Roll Call: Redlinger, Schneider, Sexton, Weber, Schnoebelen

Ayes:

Nays:

Absents:

Moved by Councilperson _____, seconded by Councilperson _____, to approve the foregoing resolution on November 7th, 2016.

Signed: _____

Allen Schneider, Mayor

Attest: _____

Lory Young, City Clerk

PERMIT APPLICATION for the CITY OF RIVERSIDE	<input type="checkbox"/>	Construction or 3 month extension permit
	<input type="checkbox"/>	Demolition permit
	<input type="checkbox"/>	Deck permit
	<input type="checkbox"/>	Sign permit
	<input type="checkbox"/>	Fence or retaining wall permit
	<input type="checkbox"/>	Pool permit
	<input type="checkbox"/>	New driveway permit
	<input type="checkbox"/>	

Note to Applicant: This is a multiple use form. Only complete the sections related to your request indicated above

This Section to be Completed by the Applicant

Applicant	Address	Phone
Address of Building Site <small>(if different than applicant's address)</small>	Address	Phone

Applicant Checklist for Requested Permit Indicated Above (attach separate sheets as necessary)

Construction or Three Month Extension Permit <input type="checkbox"/> If extension, explain reason(s) for extension and work to be completed <input type="checkbox"/> Statement describing work to be done (new house, new business, new garage, addition, etc.) <input type="checkbox"/> Statement of compliance with Zoning Code (lot size, setbacks, height, use, etc.) <input type="checkbox"/> Site Map <input type="checkbox"/> Two sets of Plans	Fee Paid: \$ Accepted by:
--	------------------------------

Demolition Permit <input type="checkbox"/> Description of demolition work <input type="checkbox"/> Asbestos removed from property <input type="checkbox"/> Water, sewer, electrical and gas shut off to property	Fee Paid: \$ Accepted by:
--	------------------------------

Deck Permit <input type="checkbox"/> Statement of compliance with Zoning Code	Fee Paid: \$ Accepted by:
---	------------------------------

Sign Permit <input type="checkbox"/> Description of sign and statement of purpose <input type="checkbox"/> Statement of compliance with Zoning Code	Fee Paid: \$ Accepted by:
--	------------------------------

Fence or Retaining Wall Permit <input type="checkbox"/> Description of fence or retaining wall <input type="checkbox"/> Statement of compliance with Zoning Code	Fee Paid: \$ Accepted by:
---	------------------------------

Pool Permit <input type="checkbox"/> Description of pool (above ground, in-ground, permanent, etc.) <input type="checkbox"/> Statement of compliance with Zoning Code	Fee Paid: \$ Accepted by:
--	------------------------------

New Driveway Permit <input type="checkbox"/> Description of work (addition, new, etc.) <input type="checkbox"/> Statement of compliance with Zoning and Subdivision Code	Fee Paid: \$ Accepted by:
---	------------------------------

Note to Applicant: All fees must be paid prior to receiving permit

Filing Date (office use only):

DEVELOPMENT APPLICATION for the CITY OF RIVERSIDE	<input type="checkbox"/>	Preliminary Plat Application
	<input type="checkbox"/>	Final Plat Application
	<input type="checkbox"/>	Rezoning Request
	<input type="checkbox"/>	Special Exception Request
	<input type="checkbox"/>	Variance Request
	<input type="checkbox"/>	Other

Note to Applicant: This is a multiple use form. Only complete the sections related to your request indicated above

This Section to be Completed by the Applicant

Development Name	Address	
Development Owner	Address	Phone
Engineer	Address	Phone
Attorney	Address	Phone
Applicant (if other than owner)	Address	Phone

Applicant Checklist for Requested Action Indicated Above (attach separate sheets as necessary)

Rezoning Requests: <input type="checkbox"/> Legal description <input type="checkbox"/> Site map <input type="checkbox"/> Statement of why present zoning is no longer valid <input type="checkbox"/> List of property owners within 200 feet of the rezoning	Fee Paid: \$
	Accepted by:
	Present Zoning:
	Proposed Zoning:

Special Exception Requests: <input type="checkbox"/> Site map <input type="checkbox"/> Statement of why special exception is being requested, including legal description and adjacent neighbors	Fee Paid: \$
	Accepted by:

Variance Request: <input type="checkbox"/> Site map with required and requested standards <input type="checkbox"/> Statement of why variance is being requested, including legal description and adjacent neighbors	Fee Paid: \$
	Accepted by:

Other: Describe request:	Fee Paid: \$
	Accepted by:

Preliminary Plat: <input type="checkbox"/> 20 copies of preliminary plat with required information	Fee Paid: \$
	Accepted by:

Final Plat: <input type="checkbox"/> 20 copies of final plat with required information	Fee Paid: \$
	Accepted by:

Note to Applicant: All fees must be paid prior to consideration by the City Council, or by any board or commission of the City of Riverside

Filing Date (office use only):

CITY OF RIVERSIDE – APPLICATIONS/ PERMITS/ FEES

NOTE: The term "addition" below means structural additions to the item. It does not include improvements to the structure such as siding, windows, or shingles.

ACTIVITY	REQUIRE APPLICATION	APPLICATION FEE	REQUIRE PERMIT	PERMIT FEE
New Home 1,200 sq. ft. or less 1,201 to 1,500 sq. ft. 1,501 to 1,900 sq. ft. 1,901 to 2,300 sq. ft. 2,301 to 2,800 sq. ft. 2,801 to 3,200 sq. ft. 3,201 sq. ft. and above	X	\$35.00	X	\$750.00 \$1,000.00 \$1,250.00 \$1,500.00 \$1,750.00 \$2,000.00 \$3,000.00
Addition to Home	X	\$35.00	X	\$1.00 per each additional sq. ft.
New Business 1,200 sq. ft. or less 1,201 to 1,500 sq. ft. 1,501 to 1,900 sq. ft. 1,901 to 2,300 sq. ft. 2,301 to 2,800 sq. ft. 2,801 to 3,200 sq. ft. 3,201 sq. ft. and above	X	\$35.00	X	\$1,000.00 \$1,250.00 \$1,500.00 \$1,750.00 \$2,000.00 \$3,000.00 \$4,000.00
Addition to Business	X	\$35.00	X	\$1.00 per each additional sq. ft.
New Garage (detached) 700 sq. ft. or less 701 to 1,000 sq. ft. 1,001 sq. ft. and above	X	\$35.00	X	\$250.00 \$500.00 \$750.00
Addition to Garage	X	\$35.00	X	\$1.00 per each additional sq. ft.
New Outbuilding	X	\$35.00	X	\$0
Addition to Outbuilding	X	\$35.00	X	\$0

CITY OF RIVERSIDE – APPLICATIONS/ PERMITS/ FEES

New Deck / Porch	X	\$35.00	X	\$0
Addition to Deck / Porch	X	\$0	X	\$0
New Fence	X	\$35.00	X	\$0
Addition to Fence	X	\$0	X	\$0
New Retaining Wall	X	\$35.00	X	\$0
Addition to Retaining Wall	X	\$0	X	\$0
New Property Access Addition to existing drive way	X	\$35.00	X	\$0
New drive way	X	\$35.00	X	\$35
Pool Above Ground <i>smaller than 3' deep (temporary)</i>	X	\$0		
In-ground or Above ground <i>larger than 3' deep (permanent)</i> <i>Including fence / gate</i>	X	\$35.00	X	\$35.00
Sign	X	\$35.00	X	\$35.00
Demolition of Principle Permitted Use	X	\$35.00	X	\$75.00
Three Month Extension to Construction Permit <i>Can be renewed</i>	X	\$35.00	X	\$0

CITY OF RIVERSIDE – APPLICATIONS/ PERMITS/ FEES

SUBDIVISION ORDINANCE	
Copy of Subdivision Ordinance.....	\$15.00
Pre-Application Conference.....	\$250.00
Minor Subdivision.....	\$750.00
Major Subdivision (3 or more lots)	
Preliminary Plat.....	\$1,250.00
Final Plat.....	\$1,000.00
 ZONING ORDINANCE	
Copy of Zoning Ordinance (including map)	\$20.00
Change of Zoning Classification (rezoning).....	\$250.00
Special Exception Request (to Board of Adjustment).....	\$250.00
Variance Request (to Board of Adjustment)	\$100.00
Appeal to Board of Adjustment	\$100.00
 OTHER RELATED ACTIONS / DOCUMENTS	
Copy of Comprehensive Plan (including maps)	\$35.00
Special Meetings of the Planning and Zoning Commission.....	\$250.00
Special Meetings of the City Council Commission.....	\$350.00



1512 7th Street • Coralville, Iowa 52241 • (319) 248-1720

Building Permits and Fees (Revised 2015)

Total Valuation	
\$1.00 to \$500.00	\$25.00
\$501.01 to \$2,000.00	\$25.00 for the first \$500 plus \$3.20 for each additional \$100, or fraction thereof, to and including \$2,000.
\$2,001.01 to 25,000.00	\$73.00 for the first \$2000 plus \$14.70 for each additional \$1000, or fraction thereof, to and including \$25,000.
\$25,001.00 to \$50,000.00	\$411.10 for the first \$ 25,000 plus \$10.61 for each additional \$1000, or fraction thereof, to and including \$50,000.
\$50,001.00 to \$100,000.00	\$676.35 for the first \$50,000 plus \$7.35 for each additional \$1000, or fraction thereof, to and including \$100,000.
\$100,001.00 to \$500,000.00	\$1043.85 for the first \$100,000 plus \$5.88 for each additional \$1000, or fraction thereof, to and including \$500,000.00.
\$500,001.00 to \$1,000,000.00	\$3,395.85 for the first \$500,000 plus \$4.99 for each additional \$1000, or fraction thereof, to and including \$1,000,000.00.
\$1,000,001.00 and up	\$5,890.85 for the first \$1,000,000 plus \$3.83 for each additional \$1000, or fractions thereof
Plan Review Fee: 25% of Building Fee (over \$100,000.00)	
Site Plan Review Fee:	\$250.00
Other Inspections and Fees:	
1. Inspections outside of normal business hours (minimum charge--two hours)	\$50.00/hr*
2. Re-inspection fees	\$50.00/hr*
3. Inspections for which no fee is specifically indicated	\$50.00/hr*
4. Additional plan review required by changes, additions or revisions (min. 1/2 hr.)	\$50.00/hr*
5. For use of outside consultants for plan checking and inspections, or both	Actual Costs**
* Or the total hourly cost to the jurisdiction, whichever is the greatest. This cost shall include supervision, overhead, equipment, hourly wages and fringe benefits of the employees involved.	
** Actual costs include administrative and overhead costs.	
6. Sign permit fees	\$50.00
7. Demolition permit fees	\$50.00
8. Excavation permit fees	\$200.00
9. Right of Way permit fees	\$200.00
10. SWPPP permit fees (\$50.00 each additional acre)	\$250.00
11. Habitat House permit fees	0
12. Sidewalk repair permit fees	\$25.00
Sewer Connection Rates:	
Business/Commercial Bldgs	\$300.00
Hotel/ Motels	\$500.00
Multi-family	\$25.00 per unit / with minimum of \$300.00
Single-family dwelling	\$100.00



1512 7th Street • Coralville, Iowa 52241 • (319) 248-1720

Coralville Fee Schedule

All submittals are due before noon on the first working day of the month
 Re-submittals deadlines will be determined by the Building Official.

SUBDIVISION FEES:		
PRELIMINARY PLATS:	Minimum fee:	\$400.00
	Up to 10 lots	
	Additional lots	\$15.00 each
FINAL PLATS:	Minimum fee:	\$300.00
	Up to 10 lots	
	Additional lots	\$15.00 each
PUD: (Planned Unit Development)		\$500.00
	plus	\$15.00 per lot
16 Copies of each submittal		

BOARD OF ADJUSTMENTS:		
CONDITIONAL USE:	8 Copies	\$300.00
APPLICABLE VARIANCES TO ZONING ORDINANCES:		\$300.00
	8 Copies	

REZONING:		\$300.00
	16 Copies	

LAND USE AMENDMENT:		\$300.00
	16 Copies	

ANNEXATION:		\$300.00
	16 Copies	

GRADING FEE:	Base Fee:	\$300.00
	plus	\$50.00 per acre

Iowa City

**PERMIT, PLAN REVIEW, INSPECTION AND LICENSING FEES
FOR IOWA CITY DEVELOPMENT SERVICES DIVISION
(Res. No. 15-69 effective July 1, 2015)**

BUILDING PERMIT FEES

<u>Total Valuation</u>	<u>Fee</u>	
\$1.00 to \$1,000	\$35.00	
\$1,001 to \$2,000	\$42.00	for the first \$1,000 plus \$3.60 for each additional \$100.00 or fraction thereof, to and including \$2,000.
\$2,001 to \$25,000	\$72.00	for the first \$2,000 plus \$10.80 for each additional \$1,000 or fraction thereof, to and including \$25,000.
\$25,001 to \$100,000	\$324.00	for the first \$25,000 plus \$6 for each additional \$1,000 or fraction thereof, to and including \$100,000.
\$100,001 to \$500,000	\$792.00	for the first \$100,000 plus \$4.80 for each additional \$1,000 or fraction thereof, to and including \$500,000.
\$500,001 and up	\$2,796.00	for the first \$500,000 plus \$3.60 for each additional \$1,000 or fraction thereof.

PLAN REVIEW FEES

1. *Dwellings permitted under the International Residential Code (IRC):* The plan review fee shall be designated as one-half of the building permit fee.
2. *All other projects requiring plan review.* The plan review fee shall be a separate additional fee equal to 65% of the building permit fee.
3. *Additional plan review required by changes, additions or revisions to approved plans:* (minimum charge - one hour) \$50.00 per hour

DEMOLITION PERMIT FEES

1. For a permit issued prior to the commencement of any demolition work \$50.00
2. For a permit issued subsequent to the commencement of any demolition work on an officially designated Historic Building or any building within a historic preservation or conservation district \$1,000.00
3. For a permit issued subsequent to the commencement of any demolition work on any other building \$200.00

GRADING PERMIT FEES

- 1. Minimum fee for the issuance of any Permit..... \$35.00
- 2. For review of grading plans \$50.00
(minimum charge - one hour) per hour

SITE PLAN REVIEW FEES

- Major Site Plan Review..... \$350.00
- Minor Site Plan Review (excluding single family and duplex dwellings)..... \$100.00

CERTIFICATE OF OCCUPANCY (C.O.)

- 1. For the issuance of a C.O. in conjunction with a building permit..... No charge
- 2. For the issuance of a C.O. in conjunction with a change in use..... \$35.00
- 3. For the issuance of a temporary C.O..... \$50.00

MECHANICAL PERMIT FEE

- Minimum fee for any permit..... \$35.00

Residential Fee Schedule

- 1. New residential permitted under the IRC (each dwelling unit)..... \$100.00
- 2. Residential remodel permitted under the IRC (per dwelling unit) \$50.00

Non-Residential Fee Schedule

- Value of work from \$1 - \$1,000 \$35.00
- Each additional \$1,000 or fraction thereof \$15.00
- Equipment Replacement \$35.00

ELECTRICAL PERMIT FEES

- Minimum fee for any permit..... \$35.00

Residential Fee Schedule

- 1. New residential permitted under the IRC (each dwelling unit)..... \$100.00
- 2. Residential remodel permitted under the IRC (per dwelling unit)
 - A. New service and associated wiring \$50.00
 - B. Rewiring or additional wiring with no service change \$50.00
- 3. Swimming pool..... \$50.00

Non-Residential Fee Schedule

- Value of work from \$1 - \$1,000 \$35.00
- Each additional \$1,000 or fraction thereof \$15.00

PLUMBING PERMIT FEES

Minimum fee for any permit.....\$35.00

Residential Fee Schedule

- 1. New residential permitted under the IRC (each dwelling unit).....\$100.00
- 2. Residential remodel permitted under the IRC (per dwelling unit).....\$50.00
- 3. Building sewer and/or water service\$50.00

Non-Residential Installations:

- value of plumbing work \$1 - \$1,000.....\$35.00
- each additional \$1,000 or fraction thereof\$15.00
- Equipment replacement fee.....\$35.00

SIGN PERMIT FEES

- 1. Minimum fee for any permit.....\$50.00
- 2. For each square foot of sign face\$1.00
- 3. Maximum fee for a special event sign.....\$50.00

LICENSING AND RENEWAL FEES

<u>License</u>	<u>Application Fee</u>	<u>Annual Renewal Fee</u>	<u>Reinstatement Fee</u>
Master Electrician	\$25.00	\$50.00	\$65.00
Journeyman Electrician	\$25.00	\$50.00	\$65.00
Maintenance Electrician	\$25.00	\$50.00	\$65.00
Sewer & Water Installer	\$25.00	\$50.00	\$65.00
Inactive Electrician	0.00	\$15.00	\$25.00
Fire Alarm Installer	\$25.00	\$50.00	\$65.00
Fire Sprinkler Installer	\$25.00	\$50.00	\$65.00
Fire Sprinkler Contractor	\$25.00	\$50.00	\$65.00
Sign Erector	\$50.00	\$50.00	\$65.00

Examination fees shall be paid to the testing agency in accordance with their fee schedules.

BUILDING MOVING LICENSE & PERMIT FEES

- Movers License for one (1) week\$35.00
- one (1) month\$50.00
- six (6) months\$100.00
- one (1) year.....\$130.00

Moving Permit for any building.....\$85.00

TEMPORARY USE PERMIT FEES

- 1. Initial Temporary Use Permit..... \$75.00
- 2. Subsequent Temporary Use Permits \$25.00
(permits issued to the same applicant for the same use at the same location within one year of the expiration of the original permit.)

OTHER FEES

- 1. Re-inspection fee \$50.00
- 2. Inspection outside of normal business hours..... \$50.00 (Minimum Charge-2 hours)
- 3. Permits or inspections for which no fee is specified \$35.00
- 4. Administrative Fee for weed mowing or snow removal \$100.00
- 5. Foundation Permits..... \$75.00
(Allowed only for structures built under the IRC. This fee is separate from and in addition to all other permit fees associated with the project. This permit is to be issued within 24 hours of receiving the application.)
- 6. Condominium conversion..... \$200.00
- 7. Minor Modification \$100.00
- 8. Board of Appeals \$100.00
- 9. Abandoned/Vacant Building
 - Registration: \$50.00
 - Annual Inspection..... \$80.00
- 10. Electronic Plan and Document Fee \$28.00
- 11. Zoning Confirmation Letter Fee..... \$25.00

City of Iowa City departments are exempt from all permit fees.

*Brent Hinson, City Administrator
Sandra Johnson, Mayor
Illa Earnest, City Clerk
Kevin Olson, City Attorney*



*City of Washington
215 East Washington Street
Washington, Iowa 52353
(319) 653-6584 Phone
(319) 653-5273 Fax*

Permit Fee Schedule

PLUMBING

One and Two Family Dwellings

Remodel or repair that requires a permit-----	\$30.00
Water service and/or building sewer-----	\$30.00
New Residential (each unit) -----	\$120.00

Commercial

Fee based on valuation of work	
Value of work \$1-\$14,000 -----	\$35.00
Value of work \$14,001-\$50,000-----	.25%
Value of work \$50,001-unlimited-----	.20%

Misc. Fee

Request Inspection -----	\$30.00
--------------------------	---------

MECHANICAL

One and Two Family Dwellings

Replace furnace and/or air conditioner or hydronic unit (each unit) -----	\$30.00
Complete new system including ductwork (each unit) -----	\$60.00

Commercial

Fee based on valuation of work	
Value of work \$1-\$14,000 -----	\$35.00
\$14,001-\$50,000 -----	.25% of estimated cost
\$50,001-Unlimited-----	.20% of estimated cost

Misc. Fee

Request Inspection -----	\$30.00
--------------------------	---------

*Brent Hinson, City Administrator
 Sandra Johnson, Mayor
 Illa Earnest, City Clerk
 Kevin Olson, City Attorney*



*City of Washington
 215 East Washington Street
 Washington, Iowa 52353
 (319) 653-6584 Phone
 (319) 653-5273 Fax*

Permit Fee Schedule

ELECTRICAL

One and Two Family Dwellings

Adding (1) new circuit -----	\$30.00
Remodel, addition to building-----	\$50.00
Service upgrade-----	\$50.00
Detached Garage -----	\$50.00
Temporary electrical service -----	\$30.00
New Construction (each unit)	
1,000 sq. ft.* or less -----	\$100.00
1,001 sq. ft.* to 3,000 sq. ft.* -----	\$130.00
3,001 sq. ft.* to 6,000 sq. ft.* -----	\$160.00
6,000 sq. ft.* or greater -----	\$190.00
* Total square feet of house, garage and basement.	

All other wiring

Temporary electrical service -----	\$30.00
100 amp service -----	\$25.00
200 amp service -----	\$35.00
Each additional 100 amp service -----	\$20.00 per 100 amp
Branch circuit and feeders -----	\$5.00 each
Sign wiring -----	\$35.00
Inspection-----	\$30.00
* Electrical print required for all commercial projects.	

SIGN PERMIT -----	\$30.00
FENCE PERMIT -----	\$30.00
MAIN SEWER TAPPING FEE -----	\$200.00
WATER SERVICE TAPPING FEE -----	\$650.00
EXCAVATION PERMIT -----	\$10.00

Fee Schedule

Wellman Subdivision Ordinance

Copy of Subdivision Ordinance	\$10.00
Pre-Application Conference	\$50.00
Minor Subdivision	\$100.00
Major Subdivision	
Preliminary Plat	\$500.00
Final Plat	\$100.00

Wellman Zoning Ordinance

Copy of Zoning Ordinance (including map)	\$15.00
Change of Zoning Classification	\$100.00
Permit for Sign	\$10.00
Permit for Fence or Hedge	\$35.00
Permit Under Mobile Home Regulations.....	\$35.00 up to \$2,000 of est. cost to construct with an additional \$0.50/\$1,000 of est. cost to construct over \$2,000

Construction or Alteration of Building Permit (Exp. 1 yr.).....	\$35.00 up to \$2,000 of est cost to construct with an additional \$0.50/\$1000 of est. cost to construct over \$2,000
---	--

One-time three month extension	\$.25/\$1,000 of est. cost to construct
Special Exception Request (to Board of Adjustment).....	\$75.00
Variance Request (to Board of Adjustment)	\$50.00
Appeal to Board of Adjustment	\$50.00

Other Related Actions/Documents

Copy of Comprehensive Plan (includes Land Use Plan)	\$ 15.00
Special Meetings of the P & Z Commission.....	\$100.00

The City of Wellman, Iowa
Development Standards and Requirements

Information for home owners, new residents, and potential builders

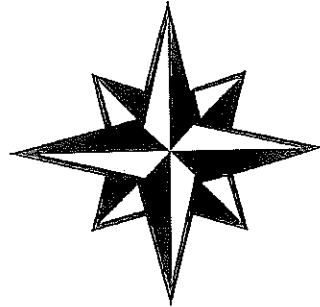

City Hall
316 8th Avenue
Wellman, Iowa 52356
646-2154

11/07/05/Revised 2008

Welcome to Wellman, Iowa

Building a home in Wellman need not be a complicated process. The purpose of this booklet is to inform potential home builders and other residents of the rules and procedures applicable to subdivision, zoning, and construction in Wellman.

The Wellman Comprehensive Plan

All development in the City of Wellman is guided by the Comprehensive Plan. This is a policy document prepared with assistance from the East Central Iowa Council of Governments covering the future development of the City of Wellman. The Comprehensive Plan provides the legal framework for the zoning and subdivision ordinances. These ordinances establish where and how development may occur in Wellman. Any land use decision will be evaluated for conformity with the goals of the Plan. This plan addresses issues such as future land use, population and economic projections, transportation needs, and how to manage future growth. A copy of the plan is available at City Hall for review. A copy may also be purchased for a nominal fee.

Necessary Permits

In Wellman, permits are required for the construction of fences and hedges, the erection of accessory buildings (garages and/or storage sheds), home remodeling or additions, the siting of mobile homes, and the erection of billboards or advertising signs. Please contact the City Clerk for information and permit applications.

Zoning Considerations

The City of Wellman is divided into five types of land-use districts: A, agricultural; R, residential; C, commercial; M, industrial and P, public. These five districts are further divided into more specific sub-districts (e.g., R1, R2, etc.). Within the residential district, for example, only residential building can occur. If a property owner of a parcel of land with one zoning designation wishes to develop the land in a different designation, a rezoning must be granted. Please contact the City Clerk for information on zoning and rezoning applications. A copy of the zoning ordinance is available for review at City Hall. A copy may also be purchased for a nominal fee.

Rezoning Application

Any rezoning application must be reviewed by the Planning & Zoning Commission. The Commission reviews applications once each month. Applications are due on the 15th of the month. The Commission meets on the last Tuesday of each month at 6:30 p.m. The following information must be submitted along with the application:

1. A cover letter explaining the purpose of your request.
2. A legal description of the area.
3. A site plan of the area, showing the location of the proposed or existing access to the property (no smaller than 1"=100'), with the area to be rezoned outlined in red, and all properties within 200 feet outlined in blue.
4. A list of all property owners within 200 feet of the lot.

Upon review by the P&Z, a recommendation is made to the City Council of the City of Wellman. At the first City Council meeting following consideration by the P & Z, the City Council will hear the request.

NOTE: The Wellman Zoning Ordinance is the law. As such, a rezoning is a change of the law requiring a new ordinance to that effect. By law, an ordinance must have three readings, and three votes by the City Council, to take effect. For this reason, expect a minimum of three months to receive final approval on a rezoning request.

Subdivision Application

Whenever a parcel of land is legally divided into two or more lots, an application for subdivision approval must be submitted to the City of Wellman Planning & Zoning Commission. The following information must be submitted along with the application:

1. A cover letter explaining the need for a subdivision.
2. Eighteen (18) copies of the preliminary/final plat, including the information required by the Wellman Subdivision Ordinance.

Upon submission of the application, the item will be placed on the agenda of the next P & Z meeting. As with zoning applications, subdivision applications must be received by the 15th day of the month. Commission meetings are held the last Tuesday of the month at 6:30 p.m.

Like the rezoning application process, the subdivision process takes a minimum of three months. This is how long it will take for the P & Z and City Council to receive, review and rule on a preliminary plat and the subsequent final plat. A copy of the subdivision ordinance is available for review at City Hall. A copy may also be purchased for a nominal fee.

Variations

When the dimensions or topography of a parcel of land create an "unnecessary hardship" of a physical (not financial) nature, the Wellman Board of Adjustment may grant a variance on bulk regulations (e.g., building setbacks, height, etc.) contrary to a parcel's current zoning requirements. An application for a variance is available at City Hall. The following information must be included with the application:

1. A cover letter explaining the nature of the request.
2. A legal description of the property, including address and zoning.
3. The required standards, requested standards, and a measurement of the difference.
4. A list of all property owners within 200 feet of the parcel.

Upon submission of the application, the item will be placed on the agenda of the next Board of Adjustment meeting. The Board meets the first Tuesday of the month at 7:00 p.m.

Special Exceptions

Within each zoning district a list is provided consisting of land uses allowed within that district only as a special exception. For example, within the single-family residential, R-1, district, child care centers are a special exception. This means that they are allowable only with the permission of the Board of Adjustment. The special exception exists to allow appropriate land uses to occur under specific conditions as set forth by the Board of Adjustment.

An application for a special exception is available at City Hall. The following information must be included with the application:

1. A cover letter explaining the nature of the request.
2. A legal description of the property, including address and zoning.
3. A list of all property owners within 500 feet of the property.

Upon submission of the application, the item will be placed on the agenda of the next Board of Adjustment meeting. The Board meets the first Tuesday of the month at 7:00 p.m.

City of Lone Tree Schedule of Fees - Schedule A

Type of Fee	Amount
New Construction	\$0.40 Sq Ft
Room Addition	\$0.40 Sq Ft
Garage	\$0.40 Sq Ft
Deck or Portable Shed (over 120 sq ft)	\$50.00
Deck or Portable Shed (under 120 sq ft)	\$35.00
Sidewalk	No Charge
Fence	\$25.00
Rezoning	\$300.00
Appeals to Board of Adjustment	\$300.00
Variance	\$300.00
Preliminary Plat	\$500.00

City of Lone Tree Schedule of Fees - Attachment B

Type of Fee	Amount
Peddler, Solicitors, Trans Merchant	\$25.00
House Movers, License, Week	\$35.00
House Movers, License, Month	\$50.00
House Movers, License 6 Months	\$100.00
House Movers, License, Year	\$130.00
House Movers Permit, under 12 Ft	\$50.00
House Movers Permit, over 12 Ft	\$85.00
Junk Dealers, Pawn Brokers, License, Year	\$200.00
Junk Dealers, Pawn Brokers, License, Month	\$20.00
Stockyards	\$200.00
Sexually Oriented Business, License	\$2,500.00
Communications Antennas & Towers	\$250.00

City of Lone Tree Schedule of Fee - Attachment C

Type of Fee	Amount
Copies, Letter	\$0.10
Copies, Legal	\$0.25
FAX	\$5.00
Dog License, Year	\$12.00
Dog License, Late	\$50.00
Vehicle Impoundment, up to 5 days	\$10.00
Vehicle Impoundment, after 5 days, per day	\$5.00
Open Burning Permit	\$10.00
Community Building Rental	\$50.00
Community Building Rental. Deposit	\$50.00
Park Pavilions, Reservations/Rental	\$20.00
Sand, Backhoe bucket full + delivery	\$35.00
Gravel, Backhoe bucket full + delivery	\$35.00
Compost, delivery charge only	\$20.00
Woodchips, delivery charge only	\$20.00

Hills

TO BE COMPLETED BY CITY STAFF

Application received by _____ Permit # _____

Zoning Requirements Inspected: _____ Date: _____

Site Zone _____ Area _____ Sq Ft _____

Fees/Escrow required _____

Conditional Zoning Requirements _____

Specific Subdivision Requirements (sidewalks, easements, drainage, etc): _____

Other Requirements _____

BUILDING PERMIT FEE SCHEDULE

Activity/Permit	Value of Improvement	Fee
Building Permit	\$1-1,500	35.00
	\$1,501-10,000	250.00
	\$10,001- 50,000	500.00
	\$50,001- \$100,000	750.00
	\$100,001- \$250,000	1000.00
	\$250,001- \$500,000	2000.00
	\$500,001-	3000.00

*adopted 2/11/10

+ Add Plan Review Fee = 50% of permit value

Calculation:

Permit Fee: \$
Plan Review Fee \$

Total: \$

Received

Receipt #

Hills

PLUMBING PERMIT APPLICATION

Building Address _____

Owner _____

Plumbing Contractor _____ Phone _____

Date _____ Lic # _____ IA Contractor Reg. # _____

Quantity	Quantity	Quantity
<input type="checkbox"/> Sinks	<input type="checkbox"/> Floor Sinks	<input type="checkbox"/> Grease Traps
<input type="checkbox"/> Lavatories	<input type="checkbox"/> Water Heaters	<input type="checkbox"/> Interceptors
<input type="checkbox"/> Tubs/Showers	<input type="checkbox"/> Water Softeners	<input type="checkbox"/> Other Fixtures
<input type="checkbox"/> Water Closets	<input type="checkbox"/> Laundry Tubs	<input type="checkbox"/> Building Sewer
<input type="checkbox"/> Dish Washers	<input type="checkbox"/> Urinals	<input type="checkbox"/> Gas Pip Outlets
<input type="checkbox"/> Clothes Washers	<input type="checkbox"/> Backflow Preventors	<input type="checkbox"/> Floor Drains
	_____ Type	

PERMIT FEES

Dollar Volume of Work	Fee
1. \$1-1500	\$50.00
2. \$1,501-5,000	\$75.00
3. \$5,001-25,000	\$100.00
4. \$25,001-50,000	\$125.00
5. \$50,001-75,000	\$160.00
6. \$75,001-100,000	\$175.00
7. \$100,001-125,000	\$200.00 +

*These costs are for residential only- commercial to be 1.5 times these amounts
 ~Inspection fees for septic tanks shall be separate - \$100 base plus time and fringes
 +Add \$25.00 for every \$25,000 of valuation thereafter
 >Add \$30.00 for inspection fee if applying for plumbing permit alone

Description of work _____

Value of Plumbing Work: \$ _____ Permit Fee: \$ _____

NOTICE: Separate permits are required for building, electrical, plumbing, heating and air conditioning, or signs. This permit becomes null and void if work or construction authorized is not commenced within 180 days, or if construction or work is suspended or abandoned for a period of 180 days at any time after work is commenced.

I agree to perform the work described herein in accordance with the plans and/or specifications submitted, and with all provision of the Electrical Code of the City of Hills.

Total Fee _____
Permit # _____

Signature of Applicant _____ Date _____ Date _____

A PERMIT MUST BE ISSUED PRIOR TO COMMENCEMENT OF WORK

Hills

ELECTRICAL PERMIT APPLICATION

Building Address _____

Owner _____

Electrical Contractor _____ Phone _____

Date _____ Lic # _____ IA Contractor Reg. # _____

PERMIT FEES

<u>Dollar Volume of Work</u>	<u>Fee</u>
1. \$1-1500	\$50.00
2. \$1,501-5,000	\$75.00
3. \$5,001-25,000	\$100.00
4. \$25,001-50,000	\$125.00
5. \$50,001-75,000	\$150.00
6. \$75,001-100,000	\$175.00
7. \$100,001-125,000	\$200.00 +

*Residential rates only- Commercial to be 1.5 times these amounts
 +Add \$25.00 for every \$\$25,000 of valuation thereafter
 > Add \$30.00 for inspection fee if applying for electrical permit alone

Description of work _____

Your contract price: \$ _____ Permit Fee: \$ _____

NOTICE: Separate permits are required for building, electrical, plumbing, heating and air conditioning, or signs. This permit becomes null and void if work or construction authorized is not commenced within 180 days, or if construction or work is suspended or abandoned for a period of 180 days at any time after work is commenced.

I agree to perform the work described herein in accordance with the plans and/pr specifications submitted, and with all provision of the Electrical Code of the City of Hills.

Total Fee _____
 Permit # _____

Signature of Applicant _____ Date _____ Date _____

A PERMIT MUST BE ISSUED PRIOR TO COMMENCEMENT OF WORK

Hills

HVAC PERMIT APPLICATION

Building Address _____

Owner _____

HVAC Contractor _____ Phone _____

Date _____ Lic # _____ IA Contractor Reg. # _____

PERMIT FEES

Dollar Volume of Work	Fee
1. \$1-1500	\$50.00
2. \$1,501-5,000	\$75.00
3. \$5,001-25,000	\$100.00
4. \$25,001-50,000	\$125.00
5. \$50,001-75,000	\$150.00
6. \$75,001-100,000	\$175.00
7. \$100,001-125,000	\$200.00 +

*These costs are for residential only- commercial to be 1.5 times these amounts
 ~Inspection fees for septic tanks shall be separate - \$100 base plus time and fringes
 +Add \$25.00 for every \$25,000 of valuation thereafter
 >Add \$30.00 for inspection fee if applying for plumbing permit alone

Description of work _____

Value of Plumbing Work: \$ _____ Permit Fee: \$ _____
 NOTICE: Separate permits are required for building, electrical, plumbing, heating and air conditioning, or signs. This permit becomes null and void if work or construction authorized is not commenced within 180 days, or if construction or work is suspended or abandoned for a period of 180 days at any time after work is commenced.

I agree to perform the work described herein in accordance with the plans and/or specifications submitted, and with all provision of the Electrical Code of the City of Hills.

Total Fee _____
Permit # _____

Signature of Applicant _____ Date _____ Date _____

A PERMIT MUST BE ISSUED PRIOR TO COMMENCEMENT OF WORK

Hills

WATER PERMIT APPLICATION

 Building Address _____
 Owner _____
 Contractor _____ Phone _____
 Date _____ Lic # _____ IA Contractor Reg. # _____

PERMIT FEES

\$350.00

This includes the water meter and hook up to Hills Municipal Water System as well as all inspections to complete the hook up.

 This permit becomes null and void if work or construction authorized is not commenced within 180 days, or if construction or work is suspended or abandoned for a period of 180 days at any time after work is commenced.

 I agree to perform the work described herein in accordance with the plans and/pr specifications submitted, and with all provision of the Electrical Code of the City of Hills.

Total Fee _____
Permit # _____

 Signature of Applicant Date **Date** _____

A PERMIT MUST BE ISSUED PRIOR TO COMMENCEMENT OF WORK

October 4, 2016



Lory Young
CITY OF RIVERSIDE
60 N Green St.
Riverside, LA 52327

BREACH OF CONTRACT (Cancellation)
Account Number: 370147000

Dear Lory Young,

It has come to our attention that you plan to cancel your service with Aramark Uniform Services. Please note that if you choose to cancel your service, you will be in breach of your service agreement, under which you have contracted for our services through 10/18/2017. If you terminate services prior to that date you will be responsible for liquidated damages pursuant to the provision you agreed to in the service agreement.

Based on your proposed cancellation date, the liquidated damages for your account total **\$3,385.64**. In addition, you will be responsible for all past due accounts receivables which presently total \$817.76 and any loss and ruin charges, which will be determined at the time of pick up of our merchandise.

Please confirm your intent to continue service with Aramark. If we do not receive confirmation within ten (10) days of the date of this letter, we will have no choice but to pursue our remedies to enforce our rights and seek payment of the foregoing amounts. We strongly urge you to reconsider your proposed cancellation of our services and we look forward to continuing our relationship.

Please contact us with your response or any questions you may have immediately.

Sincerely,

Casey Hewitt
General Manager, Waterloo, IA
Aramark Uniform Services
1-800-ARAMARK (1-800-272-6275)

RECEIVED
OCT 07 2016
BY: _____

*25% of remainder
of the contract*

 Proposal	
Company Name:	City of Riverside Office
Address:	
Contact:	Lory Young
Phone Number:	319 648 3501

Item Description	Sizes	Inventory	Unit Cost	Number of Units	Program Type	Service Frequency	Usage Cost
Steady step mat	3x10	4	\$ 15.00	2		E2W	\$ 30.00
E series mat	3x4	4	\$ 10.00	2		E2W	\$ 20.00
scrapper mat	3x5	2	\$ 8.00	1		E2W	\$ 8.00
							\$ -
							\$ -
							\$ -
							\$ -
							\$ -
							\$ -
							\$ -
							\$ -
							\$ -
							\$ -
							\$ -
							\$ -
							\$ -
Estimated Week Sub-total>>>							\$ 58.00



ONE-TIME CHARGES	
Prep	
Nametag	
Emblem	
Embroidery emblem	
Special Size	
Exchanges/ Item	
Total of Charges>>>	

OTHER CHARGES	
Total of Charges>>>	\$ -

SUMMARY OF CHARGES	
Service Charge	\$ 14.00
Total	\$ 72.00
Tax	\$ 5.49
	\$ -
Estimated Initial Delivery Total>>>	\$ 77.49
Estimated Delivery Total>>>	\$ 77.49

COMMENTS:

\$ 77.49
 x 2

 \$ 154.98

WebstaurantStore

<http://www.gotowebstore.com/8444143731BR>

Cactus Mat 1437M-B31 Catalina Standard-Duty 3' x 10' Brown Olefin Carpet Entrance Floor Mat - 5/16" Thick

Item #: 8444143731BR MFR #: 1437M-B31



Buy 2 or more

\$40.95/Each

Buy 1

\$43.99/Each

Overall User Rating

from **4 reviews**



- ✓ Traps dirt and moisture to protect floors
- ✓ Enhances safety in entrances, transition areas, and hallways
- ✓ Made of vinyl-backed, olefin material
- ✓ Easy to clean with just a vacuum or hose
- ✓ Fade-resistant 3' x 10' surface
- ✓ 5/16" thick
- ✓ Brown color

400011088347

New

Shipping:

Usually Ships in 1-2 Business Days

UPC Code:

Condition:

Overall Dimensions:

Length: 10'

Width: 3'

Thickness: 5/16"

Because this item is not stocked in our warehouse, processing and transit times will vary. If you need your items by a certain date, please contact us prior to placing your order. Expedited shipping availability may vary. We cannot guarantee that this item can be cancelled off of the order once it is placed.



Made in America

This item was made in the United States of America.

Teknor Apex Company T37S0310BR

Cactus Mat 1437M-
B23 Catalina
Standard-Duty 2' x 3'

\$8.79/Each

Cactus Mat 1437M-
B34 Catalina
Standard-Duty 3' x 4'

\$17.49/Each

Cactus Mat 1437M-
B35 Catalina
Standard-Duty 3' x 5'

\$21.49/Each

Cactus Mat 1437M-
B36 Catalina
Standard-Duty 3' x 6'

\$26.49/Each

Wet Area Floor Mats

96 Products

Anti-Fatigue Floor
Mats

137 Products

Carpet and Entrance
Floor Mats

561 Products

Carpet Protection
Floor Mats

30 Products

WebstaurantStore

<http://www.gotowebstore.com/8444143746BR>

Cactus Mat 1437M-B46 Catalina Standard-Duty 4' x 6' Brown Olefin Carpet Entrance Floor Mat - 5/16" Thick

Item #: 8444143746BR MFR #: 1437M-B46



Buy 2 or more

\$32.76/Each

Buy 1

\$35.49/Each

Overall User Rating

from **8 reviews**

- ✔ Traps dirt and moisture to protect floors
- ✔ Enhances safety in entrances, transition areas, and hallways
- ✔ Made of vinyl-backed, olefin material
- ✔ Easy to clean with just a vacuum or hose
- ✔ Fade-resistant 4' x 6' surface
- ✔ 5/16" thick
- ✔ Brown color



400011088675

New

Shipping:

Usually Ships in 1-2 Business Days

UPC Code:

Condition:

Overall Dimensions:

Length: 6'

Width: 4'

Thickness: 5/16"

Because this item is not stocked in our warehouse, processing and transit times will vary. If you need your items by a certain date, please contact us prior to placing your order. Expedited shipping availability may vary. We cannot guarantee that this item can be cancelled off of the order once it is placed.



Made in America
This item was made in the United States of America.



Cactus Mat 1437M-B23 Catalina Standard-Duty 2' x 3'

\$8.79/Each



Cactus Mat 1437M-B31 Catalina Standard-Duty 3' x 4'

\$43.99/Each



Cactus Mat 1437M-B34 Catalina Standard-Duty 3' x 4'

\$17.49/Each



Cactus Mat 1437M-B35 Catalina Standard-Duty 3' x 5'

\$21.49/Each

Wet Area Floor Mats

96 Products

Anti-Fatigue Floor Mats

137 Products

Carpet and Entrance Floor Mats

561 Products

Carpet Protection Floor Mats

30 Products

WebstaurantStore

<http://www.gotowebstore.com/844148735CH>

Cactus Mat 1487M-L35 Chevron Rib Herringbone 3' x 5' Charcoal Scraper Mat - 3/8" Thick

Item #: 844148735CH MFR #: 1487M-L35



Only

\$39.99/Each

- ✓ Unique chevron herringbone pattern hides dirt
- ✓ Coarse fibers remove debris from shoes
- ✓ Fade and stain-resistant
- ✓ Enhances safety by reducing the risk of slipping
- ✓ Made of non-woven, charcoal-colored polypropylene fibers with vinyl backing
- ✓ Recommended for entrances, elevators, loading docks, and other high-traffic places
- ✓ Lightweight and easy-to-clean

400011830663

New

Shipping:

Usually Ships in 2 Business Days

UPC Code:

Condition:

Overall Dimensions:

Length: 5'

Width: 3'

Thickness: 3/8"

Because this item is not stocked in our warehouse, processing and transit times will vary. If you need your items by a certain date, please contact us prior to placing your order. Expedited shipping availability may vary. We cannot guarantee that this item can be cancelled off of the order once it is placed.



Made in America

This item was made in the United States of America.

Cactus Mat 1487M-
L23 Chevron Rib
Herringbone 2' x 3'

\$14.99/Each

Cactus Mat 1487M-
L34 Chevron Rib
Herringbone 3' x 4'

\$30.49/Each

Cactus Mat 1487M-
L36 Chevron Rib
Herringbone 3' x 6'

\$46.99/Each

Cactus Mat 1487M-
L46 Chevron Rib
Herringbone 4' x 6'

\$64.99/Each

Wet Area Floor Mats

96 Products

Anti-Fatigue Floor
Mats

137 Products

Carpet and Entrance
Floor Mats

561 Products

Carpet Protection
Floor Mats

30 Products

Free Shipping on orders over \$99. Use coupon code: FREESHIP *Restrictions apply

1-800-975-0986
8:00am-8:00pm EST

90 DAY RETURN POLICY Weekly Deal

Help
My Account
(https://checkout.fullsource.com/secure-new/my_account.ssp)



(https://www.fullsource.com/)

Search by Keyword or Item#

SHOPPING CART
Your Cart Is Empty

Full Source (..) / Workwear (./workwear) / SC40KH

Sale / Clearance

Red Kap SC40 Men's Wrinkle Resistant Cotton Work Shirt - Short Sleeve - Khaki



(https://fullsourcemedias3.amazonaws.com)



\$17.23 / Each

★★★★☆
8 Reviews

Basic Bulk Customization



Color: Khaki

Khaki

Size: XL

XL

[Size Chart](#)

Qty:

Add to Cart

Stock Status

Free Shipping Eligible

Usually Ships in 3-5 Business Days

Item#: SC40KH
MPN: SC40KH-S

Available Customization

- ✓ Screen Print
- ✓ Vinyl Heat Press
- ✓ Embroidery

[Free Customization Quote](#)

[Free Bulk Quote](#)

More Information

Red Kap Work Shirts
Short Sleeve
Two Pockets with Button Closure
Khaki

Item Attributes

Department: Workwear (/workwear/)
Brands: Red Kap (/red-kap-workwear/)
Type: Button Down Shirts (/red-kap-shirts/)
Sleeve Length: Short Sleeve
Pockets: 2 Pockets
Closure Style: Button
Material: Cotton
Fabric: Twill
Color: Tan

UPC Codes

Small : 00036394535187
Medium : 00036394535170
Large : 00036394535163
XL : 00036394535194
2XL : 00036394535217
3XL : 00036394535224

SCREEN PRINTING
Click to Add Customization

99¢ each

Minimum of 24
One Color - One Location
Garments Sold Separately

Description Reviews (8) Return Policy & Shipping Info

Play it straight in a shirt that won't wrinkle under pressure. Our classic styling with button front and left pocket pencil stall keep this shirt working hard all day. Available in 9 colors.

- Blend: 100% Cotton
- Care: Industrial Wash, Light Soil, or Home Wash
- Closure: Seven-button front, including button at neck
- Collar: Two-piece, lined, sewn-in stays
- Country of Origin: Imported
- Fabric: 6 oz. Twill
- Facing: Stitched-down front
- Finish: Pre-cure durable press
- Pocket: Two button-thru, hex-style pockets with angled bartacks, bartacked pencil stall on left pocket



Long2XL :
00036394535330
Long3XL :
00036394535347
LongXL : 00036394535323

Part of parent company VF Imagewear, Red Kap has outfitted more than 16 million working Americans since its founding in 1923.

[View Red Kap Products](#)

Customers Also Viewed



(/red-kap-sc40gg-s/)

Red Kap SC40 Men's Wrinkle Resistant Cotton Work Shirt - Short Sleeve - Graphite Grey (/red-kap-sc40gg-s/)

★★★★☆ (8)
\$ 16.99 / Each



(/red-kap-sp20bw-s/)

Red Kap SP20 Men's Industrial Stripe Poplin Work Shirt - Short Sleeve - GM Blue/White Stripe (/red-kap-sp20bw-s/)

★★★★☆ (8)
\$ 13.99 / Each



(/red-kap-st52bk-s/)

Red Kap ST52 Men's Utility Uniform Shirt - Long Sleeve - Black (/red-kap-st52bk-s/)

★★★★★ (1)
\$ 17.99 / Each

Related Products



(/red-kap-sc30kh-s/)

Red Kap SC30 Men's Wrinkle Resistant Cotton Work Shirt - Long Sleeve - Khaki (/red-kap-sc30kh-s/)

★★★★★ (3)
\$ 18.99 / Each



(/red-kap-st62kh-s/)

Red Kap ST62 Men's Utility Uniform Shirt - Short Sleeve - Khaki (/red-kap-st62kh-s/)

\$ 15.99 / Each



(/red-kap-sc70kh-s/)

Red Kap SC70 Men's Deluxe Heavyweight Cotton Shirt - Long Sleeve - Khaki (/red-kap-sc70kh-s/)

★★★★★ (3)
\$ 23.99 / Each

Free Shipping on orders over \$99. Use coupon code: FREESHIP *Restrictions apply

1-800-975-0986
8:00am-8:00pm EST

90 DAY RETURN POLICY Weekly Deal

Help
My Account
(https://checkout.fullsource.com/secure-new/my_account.ssp)



(https://www.fullsource.com/)

Search by Keyword or Item#

SHOPPING CART
Your Cart Is Empty

Full Source (./) / Workwear (./workwear/) / Work Shirts (./work-shirts/) / SC70CH

Sale / Clearance

Red Kap SC70 Men's Deluxe Heavyweight Cotton Shirt - Long Sleeve - Charcoal



(https://fullsourcemedias3.amazonaws.com)



\$23.99 / Each

★★★★★
3 Reviews

Basic Bulk Customization



Color: Charcoal

Charcoal

Size: --

-- Select Size --

Size Chart

Qty: 1

Add to Cart

Stock Status

Free Shipping Eligible

Usually Ships in 3-5 Business Days

Item#: SC70CH
MPN: SC70CH-S

Available Customization

- ✓ Screen Print
- ✓ Vinyl Heat Press
- ✓ Embroidery

Free Customization Quote

Free Bulk Quote

More Information

Red Kap Work Shirts
Long Sleeve
Two Pockets with Button Closure
Charcoal

Item Attributes

Department: Workwear (./workwear/)
Brands: Red Kap (./red-kap-workwear/)
Type: Button Down Shirts (./red-kap-shirts/)
Sleeve Length: Long Sleeve
Pockets: 2 Pockets
Closure Style: Button
Material: Cotton
Fabric: Twill
Color: Gray

UPC Codes

Small : 00036394251926
Medium : 00036394251919
Large : 00036394251902
XL : 00036394251933
2XL : 00036394251957
3XL : 00036394251964
4XL : 00036394251971

SCREEN PRINTING
Click to Add Customization

99¢ each

Minimum of 24
One Color - One Location
Garments Sold Separately

Description Reviews (3) Return Policy & Shipping Info

This wrinkle-resistant shirt simply doesn't quit. A two-piece yoke and pocket flaps detail this hardworking favorite that stays on task so you can stay on yours.

SPEND \$150, GET \$25 IN CARHARTT BUCKS | LEARN MORE >

[HOME](#) / [MEN](#) / [PANTS & SHORTS](#) / [STYLE #B17](#)

RELAXED-FIT TAPERED-LEG JEAN

MEN'S RELAXED FIT

58 REVIEWS

**WRITE YOUR
REVIEW**

**7 QUESTIONS 7
ANSWERS**



\$34.99

\$37.99



COLOR: DARKSTONE

WAIST:

SIZE & FIT GUI

28	29	30
31	32	33
34	35	36
	40	42
Feedback 44	46	48



STUMPF CONSTRUCTION SERVICES INC

PO BOX 130
RIVERSIDE, IA 52327
www.stumpfconstructionia.com

BASEMENT MD
MOISTURE DAMAGE SPECIALIST



Phone: 319-648-3602

Fax: 319-648-2902

October 26, 2016

City of Riverside
60 N Greene Street
Riverside, IA 52327

Estimate # 671

Dear Mayor & Bryan,

Thank you for contacting Stumpf Construction Services Inc. for your project. We specialize in structural, water drainage and general construction problems and solutions.

Included below we have provided some basic information regarding our projects;

- Our Estimates and Invoices will not be itemized for Labor, Material or Equipment.
- Any alteration or deviation from the proposed estimate that are requested and approved by the owner which involves extra costs will be executed as additional work and shall be charged as such, over and above the original estimate.
- All executed agreements are contingent upon any unforeseen strikes, accidents, or delays beyond our control.
- The property owner must carry fire, tornado and all other necessary property and liability insurance.
- Our employees are fully covered by Workman's Compensation Insurance.
- Our terms are Net 15 days from the date of invoice, unless otherwise stated or agreed upon.
- This estimate is based on my visual observation; the cost could change due to any unforeseen circumstances.
- **The next page contains our estimate for work to be completed as discussed. If you would like us to perform the work please circle each line item you want, then sign and date the Estimate and return one copy to us.**
- Please provide additional phone/work or cell numbers if any and verify that your name and address are correct.
- Due to our increased volume of calls and estimates already accepted, our scheduled projects are booked for approximately 30 days, weather permitting.

If you have any questions please contact us at the number listed above or email tina@stumpfconstructionia.com.

We look forward to working with you!

Note: **Please keep this page for your records!**

Estimate

Council Packet
STUMPF CONSTRUCTION SERVICES INC
Basement MD Moisture Damage Specialist
PO BOX 130
RIVERSIDE, IA 52327

Date	Estimate
10/25/2016	671

Customer's Name & Address
 CITY OF RIVERSIDE
 21 E 1ST ST
 PO BOX 188
 RIVERSIDE IA 52327-0188

Phone	Cell phone	Email

Description of Work	Amount
ATTN: Bryan Lenz ESTIMATES FOR THE FOLLOWING WORK; These estimates are for work for 4 locations in the town of Riverside that Bryan Lenz asked me to price on October 20, 2016. 1- North Palm Street on the westside of the street on the sloped grade east of the pond where it appears there is an erosion problem. The locate showed no utilities there that may be having a problem. I probed that area and didn't find a pipe that may be having a separating problem. Remove vegetation with an excavator, blend bentonite into the existing soil, add the needed soil blended with bentonite, seed area with waterway mix, install erosion control that could be removed in the spring by the City. The watering and care of seed by City. ESTIMATE;	1,130.00
2- Corner of 4th and Washburn where it appears that a galvanized steel culvert has separated or has a hole in it. Excavate down and make a repair at this point of the pipe, backfill and seed the area with lawn mix. Watering and care of seed by City. ESTIMATE;	960.00
3- South west corner of Railroad Street & Glasgow the concrete culvert intake has started some erosion under it. We would hand dig under it, fill and pack a soil and bentonite blend in under it. ESTIMATE;	120.00
4- At the corner of 2nd and Rose Street, east of 271 2nd Street there appears to be an erosion problem. I am recommending for a more certain long term fix to fill it back up to within six inches of the top of the concrete drop box with soil blended with bentonite. Drill 1 1/2 inch holes, about six at that level through the concrete box for drain openings, then fill the area above the box with six inch rip-rap. ESTIMATE;	990.00

This estimate is based on my visual observation, the cost could change due to any unforeseen circumstances.

This estimate may be withdrawn by us if not accepted within 30 days. Should you have any questions please email tina@stumpfconstructionia.com or ronna@stumpfconstructionia.com or call us at 319-648-3602. Thank-you!

Total

11/3/2016

Estimate

~~Council Packet~~
STUMPF CONSTRUCTION SERVICES INC
 Basement MD Moisture Damage Specialist
 PO BOX 130
 RIVERSIDE, IA 52327

Date	Estimate
10/25/2016	671

Customer's Name & Address
 CITY OF RIVERSIDE
 21 E 1ST ST
 PO BOX 188
 RIVERSIDE IA 52327-0188

Phone	Cell phone	Email

Description of Work	Amount
<p>OPTION: If you want add soil and bentonite, then seeding instead, with erosion web above it ESTIMATE; (-180.00) (This amount is not included in the bottom total)</p> <p>NOTE: The four estimated costs are based on the above findings. If this is found different after excavating we would talk to you about any possible additional costs or if there would be an underground utility problem that we can't see.</p> <p>Submitted by: TERRY STUMPF, President</p>	

<p>This estimate is based on my visual observation, the cost could change due to any unforeseen circumstances.</p> <p>This estimate may be withdrawn by us if not accepted within 30 days. Should you have any questions please email tina@stumpfconstructionia.com or ronna@stumpfconstructionia.com or call us at 319-648-3602. Thank-you!</p>	<p>Total \$3,200.00</p>
--	--------------------------------

Estimate

~~Council Packet~~
STUMPF CONSTRUCTION SERVICES INC
 Basement MD Moisture Damage Specialist
 PO BOX 130
 RIVERSIDE, IA 52327

Date	Estimate
10/25/2016	671

Customer's Name & Address
 CITY OF RIVERSIDE
 21 E 1ST ST
 PO BOX 188
 RIVERSIDE IA 52327-0188

Phone	Cell phone	Email

Description of Work	Amount
ATTN: Bryan Lenz ESTIMATES FOR THE FOLLOWING WORK; These estimates are for work for 4 locations in the town of Riverside that Bryan Lenz asked me to price on October 20, 2016. 1- North Palm Street on the westside of the street on the sloped grade east of the pond where it appears there is an erosion problem. The locate showed no utilities there that may be having a problem. I probed that area and didn't find a pipe that may be having a separating problem. Remove vegetation with an excavator, blend bentonite into the existing soil, add the needed soil blended with bentonite, seed area with waterway mix, install erosion control that could be removed in the spring by the City. The watering and care of seed by City. ESTIMATE;	1,130.00
2- Corner of 4th and Washburn where it appears that a galvanized steel culvert has separated or has a hole in it. Excavate down and make a repair at this point of the pipe, backfill and seed the area with lawn mix. Watering and care of seed by City. ESTIMATE;	960.00
3- South west corner of Railroad Street & Glasgow the concrete culvert intake has started some erosion under it. We would hand dig under it, fill and pack a soil and bentonite blend in under it. ESTIMATE;	120.00
4- At the corner of 2nd and Rose Street, east of 271 2nd Street there appears to be an erosion problem. I am recommending for a more certain long term fix to fill it back up to within six inches of the top of the concrete drop box with soil blended with bentonite. Drill 1 1/2 inch holes, about six at that level through the concrete box for drain openings, then fill the area above the box with six inch rip-rap. ESTIMATE;	990.00

This estimate is based on my visual observation, the cost could change due to any unforeseen circumstances.

Total

This estimate may be withdrawn by us if not accepted within 30 days. Should you have any questions please email tina@stumpfconstructionia.com or ronna@stumpfconstructionia.com or call us at 319-648-3602. Thank-you!

11/3/2016

Estimate

Date	Estimate
10/25/2016	671

Council Packet
STUMPF CONSTRUCTION SERVICES INC
Basement MD Moisture Damage Specialist
PO BOX 130
RIVERSIDE, IA 52327

Customer's Name & Address
 CITY OF RIVERSIDE
 21 E 1ST ST
 PO BOX 188
 RIVERSIDE IA 52327-0188

Phone	Cell phone	Email

Description of Work	Amount
<p>OPTION: If you want add soil and bentonite, then seeding instead, with erosion web above it ESTIMATE; (-180.00) (This amount is not included in the bottom total)</p> <p>NOTE: The four estimated costs are based on the above findings. If this is found different after excavating we would talk to you about any possible additional costs or if there would be an underground utility problem that we can't see.</p> <p>Submitted by: TERRY STUMPF, President</p>	

<p>This estimate is based on my visual observation, the cost could change due to any unforeseen circumstances.</p> <p>This estimate may be withdrawn by us if not accepted within 30 days. Should you have any questions please email tina@stumpfconstructionia.com or ronna@stumpfconstructionia.com or call us at 319-648-3602. Thank-you!</p>	<p>Total \$3,200.00</p>
--	--------------------------------

FYI

The City of Riverside is seeking qualified individual who meets the following qualifications to work up to 29 hours per week as needed for **General Maintenance Worker** to assist in our Streets & Parks Department. Hourly wage based on qualifications and experience. Please **contact City Hall for application** or additional information about position.

RESIDENCY REQUIREMENT: Must reside within 20 miles of Riverside City Limits.

Job duties include, but are not limited to:

- Assist in maintaining and repairing city facilities, parks, streets, and equipment as needed
- Snow removal
- Assist in maintenance and repair of city vehicles and equipment
- All other duties as assigned

Required Education and Training:

- High School Diploma or equivalent
- 2 years of general maintenance experience
- Valid Iowa Driver's License

Required skills and abilities:

- Must have the ability to establish and maintain effective working relationships with City Elected Officials, Office Staff, other employees, citizens, and general public.
- Ability to stand, walk, occasional crouching, crawling, stooping, kneeling, pushing, pulling, lifting and carrying heavy objects.
- Intensive use of hands, fingers, legs, arms in grasping objects, driving equipment and using hand tools.
- Must be able to climb into cabs of various equipment, use hoist, jacks, and other related tools for maintenance and repair of various equipment.
- Must wear safety gear at all times as needed to perform duties.

Working Environment:

- Primarily outside work subject to temperature extremes at various times of year. Work is performed in numerous undesirable conditions including but not limited to: noise, dust, fumes, occasional heavy lifting and exposure to moving parts. Work may involve conditions which are potentially dangerous or hazardous including direct contact with machinery and chemicals, working from heights, in holes, and confined spaces, possible handling of hazardous materials.

Riverside is an Equal Opportunity Employer
Apply in person at City Hall
Posted per City Council Request

In Paper 10/27 + 11/3

Council Packet

11/3/2016

Big Iron Welding of Iowa LLC.

1460 Redwood Ave
Riverside, IA 52327

Estimate

Price Quote

Date	Estimate #
11/3/2016	4445

Name / Address
City of Riverside 60 N Greene St. P.O. Box 188 Riverside, IA 52327

			Project
Description	Qty	Rate	Total
Used Blade		400.00	400.00
Skid Loader Plate		425.00	425.00
Hoses and Ends		184.25	184.25
		Subtotal	\$1,009.25
		Sales Tax (7.0%)	\$0.00
		Total	\$1,009.25

City of Riverside, Iowa

Bid on 72" Snow Plow for Skidloader

Hydraulic Angle, Spring extension blade to let blade tip forward if hit something	Regular Price \$ 2,018.00
City bid price if shipped on truck load (2-3 weeks delivery)	Bid Price \$ 1,575.00



Contact Information: Ralph 319-648-2481

Schnoebelen Inc.
450 E 4th St.
Riverisde, Ia. 52327



X-treme Snow Plow

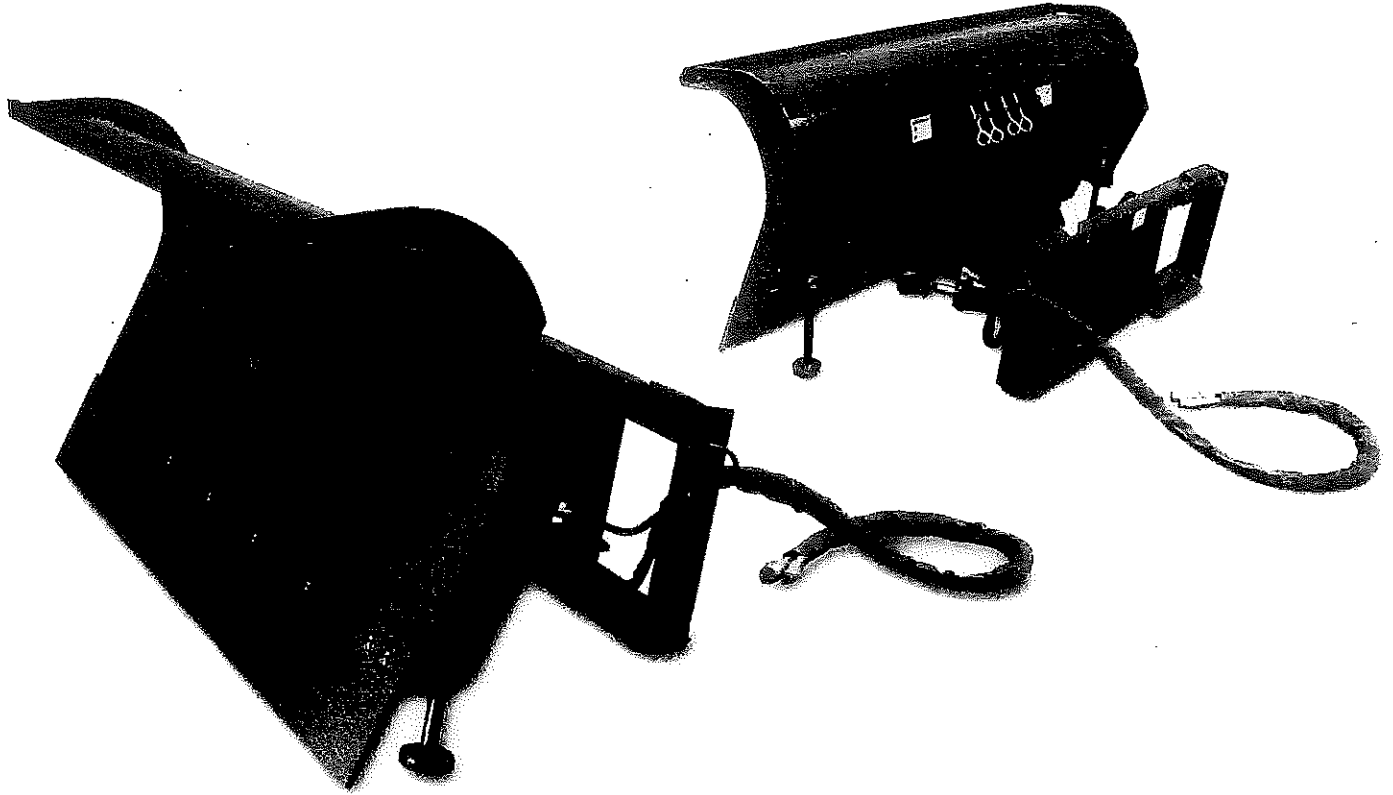

Our X-treme Snow Plow allows you to efficiently clear driveways and parking lots. Easily angle the plow from within your cab, using the 3" x 6" hydraulic cylinder. The top of the plow is rolled to keep the snow from coming back towards the cab. It's 1/2" bolt on cutting edge and adjustable snow shoes are standard.

- Easily angle the plow from inside the cab
- 3" x 6" hydraulic cylinder
- 1/2" bolt on cutting edge
- Adjustable snow shoe
- Available sizes: 72", 84", 96"

X-treme Snow Plow Specs

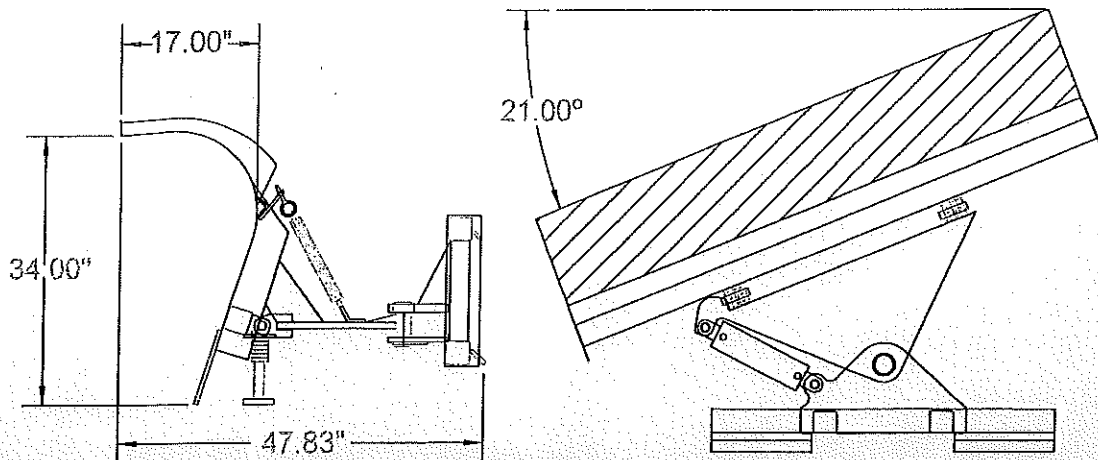

Lory Young

From: Devon Inman <dinman@elderservicesinc.com>
Sent: Thursday, November 03, 2016 3:51 PM
To: Lory Young
Subject: RE: Meals in Riverside

Lory,

Elder Services, Inc. is requesting a modification to our current understanding of congregate dining at the site in Riverside. The number of meals requested and served at the site has greatly diminished over the past year, down to an average of 6.6 meals per serving day. However, based on the average contribution rate in Riverside (\$3.95 per meal), and the \$500 per month from the Riverside Council the breakeven point for direct costs of delivering meals to the site in a minimum of 15.5 meals (this does NOT include any admin time, or meal preparation in our North Liberty kitchen).

Math behind the statements:

Staff Time to deliver from closest other drop point: .6 hr/day = \$7.20

Staff Serving Meals in Riverside ~3/day = \$26.64

Vehicle Mileage at \$.54*27.6 miles round trip = \$14.90

Raw Food Cost per Meal \$2.30

Average Number of Meals delivered per day: 6.6

Average client contribution per meal \$3.95

Average contribution per serving day from Riverside Council = $\$500 / (4.333 * 5) = \23.08

Resulting in average cost per day of \$63.92

Average contributions total: \$49.15

Deficit per day: \$14.77

Using the average contribution rate of \$3.95 minus the raw food cost of \$2.30, and dividing the difference (\$1.65) into the deficit (\$14.91) gives us 9 additional meals must be delivered per service day to break even.

Rather than ask Riverside City Council for additional monies at this time, we request that we be allowed to deliver frozen meals sufficient for average demand for the week once per week, that will be served hot by our staff daily, roughly 33 meals).

On days which the Riverside Senior Dining Center has reservations of 15 or more meals, we will deliver hot meals in the same way in which we do today.

We would of course look forwarding to working with Riverside Council to determine ways to get usage of the program up above 15 meals per day, to resume a full healthy schedule for our participants, our organization, and your city.

Sincerely,

Devon Inman
Executive Director